

MDH-Book I-V.11

MARSHALL DISTRICT HISTORY

BOOK I - GENERAL

UNCLASSIFIED

VOLUME 11 - SAFETY PROGRAM

092A

~~SECRET~~
UNCLASSIFIED

857

MDH-Book I-V.11

THIS DOCUMENT CONSISTS OF 291 PAGES
NO. 2 OF 4 SERIES A :

MANHATTAN DISTRICT HISTORY
BOOK I - GENERAL
VOLUME 11 - SAFETY PROGRAM

CLASSIFICATION CANCELLED
DATE 10-17-59
For The Atomic Energy Commission
H. F. Cansell
Chief, Declassification Branch lm

CONFIRMED TO BE UNCLASSIFIED
DOE OFFICE OF NUCLEAR AND
NATIONAL SECURITY INFORMATION
J.L. Brocky DC, IDR DATE: 10-12-05

~~SECRET~~
UNCLASSIFIED

~~RESTRICTED DATA~~
Atomic Energy Act of 1946
Specific Restricted Data
Clearance Required

~~SECRET~~
UNCLASSIFIED

FOREWORD

A Supplement to the Safety Program Volume of the Manhattan District History referring to the period from 1 July 1945 to 31 December 1946 has been included ^{following} ~~in front of~~ the original history in this volume. During this period atomic bombs were used, the war ended, security was relaxed, construction activities diminished and the Atomic Energy Commission was appointed. There was a general reduction in the number of Manhattan District contracts and considerable reorganization was in progress within the District.

In bringing this portion of the history up to date, there has been added a new section to the volume covering the fire prevention and protection phase of the Safety Program in greater detail than in the basic volume.

The numbering and subjects for Sections 1 to 6 inclusive of this Supplement conform with those of the original history, with the words "SUPPLEMENT TO" preceding each of the section numbers. Section 7 of the supplement covers a subject not included in the original history. The main paragraph numbers and subjects are in accordance with those of the original history (with the exception of the main paragraphs in Section 7) and the paragraph numbers are preceded by the letter "S". Subparagraphs, so far as practicable, are designated and in the sequence as presented by the original history.

The information covered by this Supplement has not been included in the Summary of the volume.

15 August 1947

"S" F1
~~SECRET~~
UNCLASSIFIED

~~SECRET~~
UNCLASSIFIED
Atomic Energy Act of 1946
Special Handling Data
Clearance Required

~~SECRET~~ UNCLASSIFIED

FOREWORD

1 October 1945.

The portion of the Manhattan District history contained herein covers the District Safety Program from formation of the District in August 1942, through 30 June 1945. Although some construction took place at Trail, British Columbia, and Chicago, and operations were started in several research laboratories in the fall and early winter of 1942 and were adequately covered by local safety supervisors, they were relatively small in scope and did not involve enough man-hours of exposure to provide significant safety statistics. Major District activity started with site preparation in November 1942 and actual construction in January 1943 at the Clinton Engineer Works.

Safety programs, activities and statistics discussed herein do not include the Los Alamos, New Mexico, project or its satellite subprojects which, while a part of the overall Manhattan District Project, are not under the direct supervision of the Manhattan District Engineer. Because of the necessity of close and continuous coordination with higher authority and special scientific groups in Washington, the Los Alamos work was given a special status and is handled directly from the office of Major General L. R. Groves in Washington, D. C. Activities at the Los Alamos projects, although highly important, involve as of 31 December 1944 only about 5% of the total direct employment under the District program. The history of the Los Alamos projects is recorded in Book ^{VIII} ~~III~~ of the Manhattan District History.

~~SECRET~~

~~SECRET~~

An important part of the Safety Program consists of coordination of its activities with those of the Manhattan District Medical Program, which is described in Volume 7 of this book.

Attention is invited to Section 1, Paragraph 1-2 as to the scope of the Manhattan District safety program as included in this discussion of the subject.

Fire prevention and protection are an important part of every Safety Program. During the period covered by this history the principal responsibility for fire prevention and protection was assigned to the Intelligence and Security Division whose history is contained in Volume 14, Book I. The safety staff gives special attention to fire hazards affecting personal safety.

In the Summary (which immediately follows this Foreword) the paragraph and subparagraph designations correspond to the section and paragraph designations of the main text of the history. Reference is thus facilitated from any subject in the Summary to the same subject, with greater detail, in the main text. All references to appendices and other supporting data are confined to the main text.

-12-

~~SECRET~~

~~SECRET~~
~~SECRET~~

TABLE OF CONTENTS

Par. No.

Page No.

FORWORD

SUMMARY

SECTION 1 - INTRODUCTION

1-1	General	1.1
1-2	Purpose of Program	1.1
1-3	Scope of Program	1.2
1-4	General Policy	1.2
1-5	Specific Policies	1.3
	a. Prime Contractors	1.3
	b. Area Engineers	1.3
	c. Investigation	1.4
	d. Accident Reporting	1.4
1-6	Safety Regulations	1.4
1-7	Effect of Security	1.5

SECTION 2 - OCCUPATIONAL SAFETY PROGRAM

2-1	General	2.1
2-2	General Procedures	2.1
	a. District Inspections	2.1
	b. Safety Engineers	2.2
	c. Inspection Reports of Areas	2.2
2-3	Construction Safety	2.3
	a. Safety in Design	2.3
	b. Safety Procedures in the Field	2.4
	c. Special Problems	2.4
	d. Efficiency	2.5
2-4	Operations Safety	2.5
	a. Operations Safe Practices	2.5
	b. Contractors' Procedures and Practices	2.6
	c. Research Laboratories	2.7
	d. Adaptation of Old Buildings	2.7
	e. Liaison with Medical Branch	2.7
	f. Monthly Progress Reports	2.8
2-5	Safety Training	2.8
	a. Special Courses	2.9
	b. Rule Books	2.9
	c. Newspapers	2.9
	d. Driver Training Courses	2.10
	e. Films	2.10
	f. Posters	2.10

<u>Par. No.</u>		<u>Page No.</u>
SECTION 2 - OCCUPATIONAL SAFETY PROGRAM (Cont'd)		
2-6	Accident Reporting	2.10
	a. ASF Changes, January 1944	2.11
	b. ASF Changes, April 1944 and Subsequent	2.11
SECTION 3 - PUBLIC SAFETY PROGRAM		
3-1	General	3.1
3-2	Traffic Safety	3.1
	a. Traffic Engineering	3.1
	b. Motor Vehicle Driver's Permits	3.3
	c. Enforcement of Traffic Regulations	3.3
	d. Government Vehicle Inspection	3.5
3-3	Community Safety	3.5
	a. School Safety	3.5
	b. Home Safety	3.6
	c. Recreation Safety	3.7
	d. National Safety Council Surveys	3.7
	e. Community Safety Shows	3.8
	f. Off-the-Job Safety	3.8
SECTION 4 - OTHER SAFETY ACTIVITIES		
4-1	Safety Materials and Equipment	4.1
	a. Literature	4.1
	b. Equipment	4.1
4-2	Periodic Meetings of Safety Personnel	4.2
	a. Local Meetings	4.2
	b. National Conferences	4.2
4-3	Medical Care	4.2
4-4	Contests	4.3
SECTION 5 - ACCOMPLISHMENTS		
5-1	Occupational Safety Record	5.1
	a. Magnitude of the District Safety Program	5.1
	b. Methods of Comparison	5.1
	c. Units of Comparison	5.2
	d. Trend of District Injury Rates	5.3
	e. Comparisons of District Construction Injury Rates	5.4
	f. Comparisons of District Operations Injury Rates	5.5

SECTION 5 - ACCOMPLISHMENTS (Cont'd)

	g. Savings Effected by District Safety Program	5.5
	h. Insurance Savings	5.6
	1. Detailed District Safety Records	5.6
5-2.	Traffic Safety Record	5.7
5-3	Quality of Accomplishment	5.8

SECTION 6 - ORGANIZATION

6-1	Formation	6.1
6-2	Development	6.1
	a. June to December, 1943	6.1
	b. January to June, 1944	6.2
	c. July to December, 1944	6.3
	d. January to June, 1945	6.3
6-3	Present Organization and Responsibilities	6.3
	a. The District Safety Engineer	6.4
	b. The Occupational Safety Section	6.4
	c. The Safety Training and Off-the-Job Safety Section	6.4
	d. Resident Safety Engineers	6.4
	e. Clinton Engineer Works Central Facilities	6.5
	f. Hanford Engineer Works	6.5
6-4	Personnel	6.5
	a. Calibre of Personnel	6.6
	b. Key Personnel	6.6
6-5	Contractors' Safety Organizations	6.7
	a. Organization	6.8
	b. Personnel	6.8
6-6	Cost of the Safety Program	6.8
6-7	Assistance From Government Agencies and Other Organizations	6.9
	a. Office, Chief of Engineers	6.9
	b. National Safety Council	6.9
	c. American Red Cross	6.9
	d. International Association of Chiefs of Police	6.10
	e. U. S. Department of Interior	6.10
	f. U. S. Department of Labor	6.10

APPENDIX "A" - CHARTS AND GRAPHS

APPENDIX "B" - TABULATIONS

APPENDIX "C" - DOCUMENTS

~~SECRET~~

SECTION 6 - ORGANIZATION (Cont'd)

APPENDIX "D" - FORMS

APPENDIX "E" - PHOTOGRAPHS

APPENDIX "F" - SAFETY PROMOTION MATERIALS

APPENDIX "G" - NATIONAL SAFETY COUNCIL
SURVEY (Bound Separately)

APPENDIX "H" - FILE REFERENCES

INDEX

~~SECRET~~
SUMMARY

1. Introduction. The Manhattan District has had an unusually wide variety of accident prevention problems arising from construction, plant operation, and community management. The purpose of the safety program has been to reduce the number and severity of accidents to a minimum and increase efficiency. Its scope has included employees of the Government and all construction or "cost-plus" contractors, and residents of District-operated communities. The general policy has been to utilize every practicable means to eliminate accident, fire and health hazards, and to place responsibility for safety on line officers, utilizing qualified safety engineers as technical consultants. Prime contractors have been required to develop an adequate accident prevention program and most Area engineers to have a full-time safety engineer. Thorough investigation of accidents, and detailed accident reporting have also been required. The construction safety regulations of the Corps of Engineers have been enforced, supplemented where necessary for operations. The effect of security was to impede normal accident prevention pressures and means, but this effect was offset by the comprehensive safety program.

2. Occupational Safety Program. The function of the occupational safety program has been to prevent injuries to employees on construction and in plant and laboratory operations. The general procedures were: District inspections, which were particularly valuable in smaller Areas, and resident safety engineers on all major projects who forwarded inspection reports of Areas to the District Office. Construction

safety included safety in design and safety procedures in the field. Special problems which arose due to the urgency of the District program, required unusual procedures, but the close relation between safety and efficiency was demonstrated. Operations safety was based on safe practices contained in established codes and standards, and the contractors procedures and practices developed from experience. Research laboratories presented unusual problems. The Safety Branch has maintained close liaison with the Medical Branch to control radioactive and other hazards peculiar to District work. Information on Safety programs was kept up to date by monthly progress reports prepared for operating contractors at Clinton Engineer Works. Safety training was included in indoctrination and job training and, in addition, special courses, safety rule books, stories in community and plant newspapers, and driver training courses were used. Safety films and posters were also widely used. The accident reporting procedures of the Corps of Engineers were established in the District early in 1943, and the ASF changes, January 1944, were adopted, but ASF changes, April 1944 and subsequent were not adopted because of the District's unusual organization.

3. Public Safety Program. Public safety programs were needed in Richland and Oak Ridge, the two District-operated towns. Traffic safety was based, first, on traffic engineering which aided in the planning and development of roads for elimination of congestion as well as for accident prevention. In addition, motor vehicle driver's permits were required for operation of a Government-owned

vehicle. They were issued on the basis of tests established by the Office, Chief of Engineers, and accurate records of test results and driving experience were maintained. Enforcement of traffic regulations based on a traffic code, was a responsibility of Auxiliary Military Police and Military Police. Special police training raised the quality of traffic accident investigation and other traffic work to a high level. Government vehicle inspection standards were rigidly maintained. Community safety included school safety; home safety, with a model trailer home, a model safe home, home safety courses, and other activities; and recreation safety. National Safety Council surveys aided in establishing the community programs. Community safety shows promoted both on-the-job safety and off-the-job safety.

4. Other Safety Activities. The safety materials and equipment utilized included literature and posters obtained through the Office of the Chief of Engineers and other sources, and equipment for tests for flammable and toxic substances. Periodic meetings of safety personnel were held, both local meetings and national conferences. Medical care fulfilled requirements of the Corps of Engineers. Safety programs were sometimes stimulated by conducting contests of various types.

5. Accomplishments. The occupational safety record has been outstanding -- injury rates averaged 62 percent below comparable rates for private industry. The magnitude of the District safety program may be judged from the 30-month total of 547,883,796 employee-hours worked. Trends of injury rates and comparisons with other groups are

the two methods of comparison used to evaluate the District's record. National standard units of comparison, such as "frequency rate" "severity rate" and "fatality rate" have been used. The trend of District injury rates has been generally downward. The comparisons of District construction injury rates and comparisons of District operations injury rates show that rates have been far below private industrial rates and generally lower than rates for comparable work supervised by other War Department agencies. The savings effected by the District safety program in 30 months amounted to 94 lives, 9200 disabling injuries, and 814,000 employee-days of work and substantial insurance savings will result. The detailed District safety records show month-by-month reductions in rates and show that rates in most Areas were low. The traffic safety record at Clinton Engineer Works was equal to, if not better than, the average record of older, well-established communities. The quality of accomplishment is impressive.

6. Organisation. The formation of an adequate safety organization was initiated in August 1942. The development of the organization is shown by the history from June to December 1943 when a District Safety-Accident Prevention Section with Construction, Industrial, Training, Traffic and Community Units was formed; from January to June 1944 when community safety activities at Clinton Engineer Works were assigned to an Advisory Committee and a contractor; from July to December 1944 when community safety was again consolidated in the District safety organization; and from January to June 1945 when the major proportion of the District staff was assigned direct to Officer-In-

~~SECRET~~

Charge at Clinton Engineer Works. The present organization shows the District Safety Engineer coordinating the entire District program, with the Occupational Safety Section and the Safety Training and Off-the-Job Safety Section directly under him. Resident Safety Engineers are stationed with most Area Engineers and Officers-In-Charge, Clinton Engineer Works Central Facilities and Hanford Engineer Works having sub-sections responsible for various phases of their programs. The Government Safety personnel of the District reached a peak of 72 on 30 June 1944 of whom 36 were Army or civilian engineers, the calibre of personnel being generally excellent and many key personnel outstanding. The contractors' safety organizations were also excellent, each contractor following normal corporate organization and policy and the larger contractors employing fully qualified personnel. The total cost of the safety program has been estimated at \$2,800,000, or \$1.00 per month per employee. Valuable assistance was obtained from Government agencies and other organizations, particularly the Office, Chief of Engineers, National Safety Council, American Red Cross, International Association of Chiefs of Police, U. S. Department of Interior, and U.S. Department of Labor.

~~SECRET~~

~~SECRET~~

MANHATTAN DISTRICT HISTORY

BOOK I - GENERAL

VOLUME 11 - SAFETY PROGRAM

SECTION 1 - INTRODUCTION

1-1. General. The Manhattan District has faced and is continuing to encounter an unusually wide variety of safety and accident prevention problems. This has been principally due to the extremely wide scope of the District's program which encompassed a range of activity extending from conventional industrial construction to the operation of plants which were unique in design and purpose and which required new and unusual techniques and procedures. Added to this was the construction and management of two full-scale towns providing all the necessary living facilities for about 90,000 persons.

1-2. Purpose of Program. The objective of the Safety and Accident Prevention Program of the Manhattan District has been to reduce the number and severity of accidents to a minimum by safety engineering, safety education, and enforcement of established safety regulations for the protection of all employees and for the efficient conduct of all work. The basic purposes of the District's safety and accident prevention activities have been employee welfare, improved efficiency and elimination of loss in equipment, manpower and materials. The close relationship of safety and working efficiency has been generally acknowledged by outstanding industrial firms, engineers and engineering societies. A high degree of safety contributed to the early completion of the job, not only through improvement of supervision and work techniques, but

~~SECRET~~

also through improved employee morale.

1-3. Scope of Program. The activities and direct responsibilities of the Manhattan District Safety Program included, and its policies have been applicable to: the occupational activities of the District's governmental employees; residents of government-owned, District-operated communities; contractors and their subcontractors engaged in construction on behalf of the District, and operations contractors receiving direct reimbursement for payroll costs from District funds. (See App. C 1 and H 1). Only such contractors have been included in this discussion of the District Safety Program and in the statistics used herein, as distinguished from such contractors as lump sum and unit price suppliers. This is in accordance with established (but unwritten) policy of the Corps of Engineers, which does not insert the accident prevention clause (See App. C 3, page IX) in ordinary supply contracts.

The scope of the District safety program, and of this discussion, does not include ⁿprincipal responsibility for fire prevention and protection, and production security of supply contracts, (See Book I, Volume 14, Intelligence and Security), nor for sanitation, medical facilities, and the evolution of protective measures for hazards associated with materials and processes peculiar to the District's work (See Book I, Volume 7, Medical Program). The safety staff had certain secondary responsibilities in these fields, as defined in App. C 1, Section V, Joint Responsibilities.

1-4. General Policy. The general policy of the District has been to utilize every practicable means to eliminate or minimize all acci-

~~SECRET~~

dent, fire, and health hazards in its operations, to provide such personal protective devices, equipment and apparel as the type of work exposure may require; and to maintain a comprehensive and continuous accident prevention program for the purpose of preventing deaths, injuries, occupational sickness and disease to employees and the destruction of and damage to materials, equipment, plant and other property. The guiding principles of this policy may be found in O & R, C. of E., Chapt. XI, (See App. C 2).

Although a staff of qualified, experienced safety engineers has been recruited, it was the policy of the District that the safety engineers served in an advisory capacity and that the full responsibility for safety rested on the officers in charge of construction or operations. (See App. C 1, Section IV, Organization).

1-5. Specific Policies. The specific safety and accident prevention policies of the District required the following procedures:

a. Prime Contractors. For each District prime contractor:

- (1) The development of an adequate safety and accident prevention program as a contractual obligation.
- (2) Accountability for the accident experience of their subcontractors.
- (3) Employment of a full-time safety engineer when employing one thousand or more persons (including subcontractors) or when employing less than this number if engaged in unusually hazardous work warranting continuous safety engineering.

b. Area Engineers. A full-time resident safety engineer on the staff of each Area Engineer who supervised a personnel exposure of

~~SECRET~~

~~SECRET~~

80,000 or more man-hours per month (approximately 400 employees).

At other Areas where the number of employees did not warrant a full-time safety engineer, a qualified individual was assigned responsibility for safety in addition to other duties.

c. Investigation. The thorough investigation of all occupational accidents involving government and contractor employees, not only to prevent their recurrence at the same site, but also to develop experience, policy and training procedures to prevent them from occurring elsewhere. Boards of investigation, consisting of officers, civilian engineers or specialists, and safety engineers, were appointed after fatal accidents. The reports of these Boards (See App. H 2) are examples of exceptional thoroughness of investigation and steps are cited to prevent recurrences of the accidents. Investigations and reports follow detailed procedures outlined in District Circular Letter, Safety 44-5 (See App. H 1).

d. Accident Reporting. The detailed reporting of individual lost-time injuries involving government and contractor employees on standard War Department forms (See Par. 2-6 and App. D 1). Monthly accident analyses were maintained for each project in the District Safety Branch and corrective action was taken when hazards or unsatisfactory experience developed.

1-6. Safety Regulations. The Corps of Engineers' Manual "Safety Requirements for Excavation, Building, Construction" (See App. C 3) furnished the safety instructions to construction contractors by which

1.4

~~SECRET~~

~~SECRET~~

safety observance and enforcement was measured by District Safety personnel. The safety requirements contained in this manual, to the extent applicable, together with the best accepted safe practices of private industry, have been applied to the operations activities of the District, with amendments and additions being made where necessary to meet the special problems encountered. District Circular Letters and Memos amplify the basic safety policies and requirements of the District (See App. H 1).

1-7. Effect of Security. The immediate and first effect of the District's strict security program was to cut off some of the normal pressures and forces which foster accident prevention in any industrial organization. Frequently the unit of a corporation which was engaged in Manhattan District work had no day-to-day contact with the parent corporation's established safety program. In most instances representatives of State Departments of Labor and workmen's compensation insurance companies were denied access to District facilities. The District had to assume heavier safety responsibilities and give assurance to outside agencies that safe working conditions were being maintained (See App. H 3). To supply safety promotion materials without revealing the size and location of sub-projects, orders for materials from the National Safety Council were consolidated in the District Safety Branch and ordered through the Office of the Chief of Engineers. Since information on special problems and their solutions could not be widely circularized among the Areas and the contractors, efforts were made to insure frequent personal contact by the District safety staff so

1.5

~~SECRET~~

~~SECRET~~

that the classified safety information which was needed at a particular location was supplied.

1.6
~~SECRET~~

~~SECRET~~

SECTION 2 - OCCUPATIONAL SAFETY PROGRAM.

2-1. General. Occupational safety has had as its functions the prevention of injuries and illnesses to persons working within the District's program from sources connected with their employment, and the prevention of accidental damage to equipment. It has been divided into two subclassifications - that concerned with construction of buildings and facilities, and that concerned with the operation of production plants, experimental plants, and research and development laboratories.

This section outlines principally the activities of the safety engineers. However, it must be remembered that safety is an executive, administrative, and technical responsibility, and that many important safety policies and activities were integrated in daily operations. It is significant that project directors, as they daily entered the Administration Building at the Clinton Engineer Works, headquarters of the District and the Clinton Engineer Works, saw the big Universal Safety emblem atop the gatehouse (See App. E 1).

2-2. General Procedures. As may be noted from the description of its organization, (See Sec. 6), the Safety and Accident Prevention Branch grouped its activities into three general classes - Occupational Safety, Training Safety and Public or Off-the-Job Safety. The training program is included in this section, since it was principally an occupational safety activity.

a. District Inspections. The District has maintained a safety inspection service, directly under the District Safety Engineer,

~~SECRET~~

which was particularly valuable in the cases of the smaller Areas, most of which were concerned with research and development projects. Examples of the type of inspection report which were prepared, and customarily furnished to the Area Engineers concerned, are shown in Appendices C 4 and H 4. Inspection for physical hazards was especially thorough, since because of secrecy restrictions, the usual inspections of insurance and state agencies were not permitted. Also, because of the secret nature of research work and the fact that laboratory and test personnel were often faced with new, highly technical problems, it was not always possible to anticipate the hazards involved or to protect such personnel fully from the consequences of unsafe acts.

b. Safety Engineers. Qualified safety engineers have been assigned as resident personnel on all major construction and operations projects, and full supervision was maintained. Safety coverage of District projects by District safety personnel is shown in Appendix B 1.

c. Inspection Reports of Areas. The Resident Safety Engineer in each Area prepared semi-monthly or monthly inspection reports for construction and for operations on Engineer Department Form 404. (See App. D 2 and H 5). These served as a detailed record of hazards called to the attention of contractors and provided a periodic report to the Area Engineer so that he was continuously informed of conditions in the work under his supervision. A copy of the Form 404 report was forwarded to the District Safety Branch where it was checked for progress in correcting any unsatisfactory conditions revealed in the last District inspection, and supplemented District records of the continuous

~~SECRET~~

progress in each facility.

2-3. Construction Safety. This program has integrated safety engineering in both the planning and construction of buildings and other facilities coming within the District program.

a. Safety in Design. Basically, the problem of building safety into a facility at the planning and design stages is a responsibility of architectural and design engineers. However, the Safety and Accident Prevention Branch has provided the technical safety engineering assistance required by the construction contractors and government engineers when unusual or specialized design problems occurred. Furthermore, as possible improvements in the design of facilities developed from use, suggestions were made by the Safety and Accident Prevention Branch and the improvements were incorporated into the plans for future construction of similar facilities.

The bins or tanks on the tracks at the Electromagnetic Plant are outstanding examples of safety in design. There are exposed high voltage parts inside of the bins; consequently, protection had to be provided for workers who were required to enter the bins in connection with maintenance and other work. Not one but five guards were built into the latest type tanks. First, a telephone was provided so that the cubicle, or control, room could be notified to shut off the electric current. Second, a Keylocked switch was set on the face of the bin and the key could be withdrawn only when the switch was in the off position which was visibly indicated by lights. Third, this same key was needed to open the doors giving access to the inside of the bin.

2.3

~~SECRET~~

~~SECRET~~

Fourth, the doors were equipped with interlocks which automatically cut the current when the doors were opened. And fifth, a grounding hook was provided to be placed on current-carrying parts before entering the tank.

b. Safety Procedures in the Field. As for field construction, the construction safety program, insured that construction contractors provided: adequate and safe drinking water; ample and sanitary toilet facilities; necessary first aid; infirmary and ambulance service; personal protective equipment, such as goggles, "hard hats" and safety shoes; proper accident reporting; safe transportation of workers; proper disposal of scrap, waste and trash; periodic boiler inspection; accepted safe practices in excavations, scaffolds and the use of ladders; safe hoisting materials and machinery; proper storage of combustible materials; safe installation of electrical wiring; supervised and experienced handling and storage of explosives; full and efficient fire prevention and protection.

c. Special Problems. Special problems arose due to the urgency of the District program. For example, construction often progressed so rapidly that men were working on four successive levels of a job. This necessitated special precautions, such as "hard hat areas" with rigid enforcement, closing, as well as barricading, of floor openings, and scheduling of operations to make maximum use of personnel and yet avoid placing a hazardous operation over the heads of other workers. In at least one instance (E. I. du Pont de Nemours & Company at the experimental pile plant) steel erection proceeded at night, a very unusual operation, and it was necessary to give great attention to

2.4
~~SECRET~~

adequate, shadowless lighting to continue work in safety.

d. Efficiency. An outstanding example of the close relation between production and safety was reported by the J. A. Jones Construction Company. A crew was operating vacuum cleaners in dust control work in the Gas Diffusion Plant which started operation while some construction remained. The men had worked on overhead beams and trusses for a short time without life lines. When safety belts and lines were provided, the speed of the crews increased so that the personnel required on that job could be cut in half.

2-4. Operations Safety. The operations safety program insured safe working conditions when construction was completed and the operation of plants started. It also included safety in the numerous research and development laboratories and highly specialized cost-plus supply contracts.

a. Operations Safe Practices. Operations safe practices could not be as standardized nor codified as those used in construction work. In plants of unique design, and in laboratories where work was concerned with the new and the undeveloped, safe practices had to be developed on the basis of common sense, experience, and adaptation from established procedures in similar lines of work. The broad experience represented by the Safe Practices Pamphlets of the National Safety Council and the detailed codes and specifications of the American Standards Association, the National Board of Fire Underwriters, the National Fire Protection Association and other, similar groups were valuable in establishing safety procedures for operations contractors

whose work was beyond the scope of the Corps of Engineers Manual, "Safety Requirements for Building, Excavation, and Construction". The Index to the Safe Practices Pamphlets, (See App. C 5), shows the wide range of subjects covered in this series, and the two examples of pamphlets and standards included in Appendix C 5 illustrate the wealth of detailed procedures and specifications employed to safeguard personnel.

b. Contractors' Procedures and Practices. Operations safety in the Manhattan District leaned heavily on the experience, ingenuity and good practice of plant operating contractors. Contractors were encouraged to use the established safety procedures and policies of their parent organizations, wherever applicable to District work. The principal activity of the District operations safety group in this regard consisted of advice and assistance to these contractors in working out new methods and practices, and adapting known and tried practices to the particular operations involved. Major operations contractors developed detailed safety rules and procedures for their principal operations. These combined standard industrial practices with the special precautions required for materials and processes peculiar to the District, and related both to the actual working conditions in particular departments. In most instances the safety rules were distributed to all employees concerned. Discipline and enforcement of safe practices, particularly in new organizations and with inexperienced personnel, can only be practical when written rules exist. Examples of contractors' bulletins and rule books are attached as App. C 6 through 10.

~~SECRET~~

c. Research Laboratories. Special attention was given to research and development laboratories operated by universities, which, as a result of the projects undertaken for the Manhattan District, were confronted with a volume and variety of work far in excess of their peacetime pursuits. Obstacles to an effective safety program in research facilities were: (1) lack of previous experience with industrial accident prevention techniques, (2) pre-occupation with urgent, technically complex research problems, and (3) the looser supervision and inexperience in industrial administration normal in a collegiate institution. In most instances these obstacles were eliminated or circumvented.

d. Adaptation of Old Buildings. Many of the contractors were confronted with almost overwhelming problems of safeguarding hazardous work in old buildings, ill-suited to chemical research or production, with extreme congestion of the work. The urgency of the District program, plus the desire to keep construction to a minimum, forced the employment of old, existing structures. The University of Chicago, for example, housed some of its most important operations in an old brick building which had at one time been a brewery and later a stable. The Monsanto Chemical Company converted to laboratories two widely divergent structures - an old, 4-story brick schoolhouse and a rambling "Little Theatre" development, complete with greenhouses!

e. Liaison with Medical Branch. An important activity of the Operations Safety group has been maintenance of close and continuous liaison with the District Medical Section, and contractor medical specialists and safety groups in controlling and eliminating

~~SECRET~~

~~SECRET~~

radioactive and other hazards peculiar to operations in research laboratories, and the Electromagnetic, the Experimental Pile, the Gas Diffusion and the Thermal Diffusion plants at the Clinton Engineer Works and the Production Pile plant at the Hanford Engineer Works. Inasmuch as these plants presented, in reality, highly specialized industrial medical problems, their handling and treatment are described in Volume 7 of this book, entitled "Manhattan District Medical Program".

f. Monthly Progress Reports. The Government safety personnel who were assisting operating contractors at Clinton Engineer Works rendered monthly reports on the safety program of each contractor. Accomplishments during the month were listed. The principal problems for the coming month were stated. These reports directed the attention of all concerned to the conditions which were causing accidents, focused efforts on major objectives, and served to measure month-to-month progress. These reports (See App. C 11 and E 4) provided a continuous story of safety activities and progress at each facility.

2-5. Safety Training. The teaching of modern safety techniques for supervisory as well as other levels of government and contractor employees was a continuing function of the Safety Training Section. Safety training engineers co-operated with the contractors' safety departments in providing safety training, beginning with employees' indoctrination periods and following through in all job training courses. The safety training programs of the contractors had to be adjusted to two basic conditions - first, a large proportion of the employees had no previous industrial experience, and second, it was not possible to every case to explain why a certain procedure was necessary but only

~~SECRET~~

emphasize that it was necessary.

a. Special Courses. Special training courses have been established for positions considered especially hazardous, and for positions where accident analyses showed the need for them. For example, in January 1944 the accident records revealed that carpenters, a principal class of workers on Clinton Engineer Works construction, had had 91 accidents and also had an injury rate above the construction average. Reports showed that four out of five carpenter accidents could be at least partially attributed to a supervisory failure, so a bulletin describing the specific conditions and unsafe acts which supervisors had either failed to recognize or failed to eliminate was prepared (App. F 1). This bulletin served as the informal text in a series of contractor-sponsored training and discussion meetings for carpenter foremen.

The courses of training provided through the co-operation of the U. S. Bureau of Mines (See App. F 4) and U. S. Department of Labor were valuable additions to the training program.

b. Rule Books. Rule books, containing not only general safe practices, but also specific safe practices for different types of work, have been developed by operations contractors. (See App. C 6 through 10). The series of over 500 Safety Instruction Cards available from the National Safety Council was widely used by contractors to place in the hands of a workman the specific, detailed information he required to work safely at his job. Examples of these cards are shown in App. F 2.

c. Newspapers. Contractors have made considerable use of house organs in disseminating safety information to all strata of

employees. A monthly digest of public safety news was prepared by the District Safety Branch for use of house organ editors at Clinton Engineer Works (See App. F 3). The town newspapers at Clinton and Hanford Engineer Works featured safety news and information, the emphasis being on off-the-job hazards to which workers or their families were exposed (See App. F 4). Some contractors published safety news periodicals (See App. F 5).

d. Driver Training Courses. Three contractors with large fleets, Carbide and Carbon Chemicals Corp., Roane-Anderson Company and American Industrial Transit, set up formal training programs for new motor vehicle drivers (App. E 2). Others gave driver training through normal supervisory channels.

e. Films. A complete library of visual aids, including films and projectors, has been maintained by the Safety Training Section for use by the contractors in their safety training activities. A list of films available for loan to contractors is shown as App. F 6.

f. Posters. Government employees, by and large, were engaged in office and administrative work not involving industrial hazards. A monthly safety bulletin was, however, circulated and normally used as a poster, assisting in keeping the Government injury rate at a low level (App. F 7). (See Par. 4-1 for further use of posters and materials).

2-6. Accident Reporting. The investigation and reporting of accidents is fundamental in control of accident-producing causes. The first comprehensive Manhattan District instructions on occupational

~~SECRET~~

injury reporting were issued in District Circular Letter (Safety 43-1), dated 27 April 1943 (See App. H 1). This circular was based on the accident reporting procedure then used by the U. S. Engineer Department and contained in Orders and Regulations (App. C 2) and instructions issued thereunder.

a. ASF Changes, January 1944. ASF Circulars No. 115, dated 10 November 1943, and No. 2, dated 3 January 1944, and OCE Circular Letter No. 2687, dated 14 January 1944, prescribed changes in occupational injury reporting procedures which were transmitted to the Areas of the District by District Circular Letter (Safety 44-10) dated 25 January 1945 (See App. D 1 and 2, and H 1).

b. ASF Changes, April 1944 and Subsequent. ASF Circular No. 118, dated 28 April 1944, transmitted new forms to be used for occupational injury reporting. The adoption of these and subsequent changes in ASF reporting procedures were thoroughly discussed at the time the various circulars were received with these findings:

(1) The widespread geographic distribution of District facilities, with consequent decreased personal contact, plus the fact that many facilities, such as collegiate laboratories, had no prior experience with occupational injury reporting, made it impractical to revise completely forms and procedures after a four-month period devoted to instruction in use of the previous forms.

(2) The new ASF forms eliminated severity information. District facilities had had no trouble obtaining the information after proper instruction. It is standard private industrial practice to collect severity information.

~~SECRET~~

~~SECRET~~

(3) The new ASB cause analysis forms could not be properly compiled by many District facilities with limited experience in accident reporting. Furthermore, such reports could be compiled at the District level, if relaxation of security regulations permits forwarding of required reports to higher authority.

(4) The ASB directive which prohibited requiring injury reports from private industry, except for ordnance explosives, chemical warfare, and new military construction contractors, was interpreted to permit the requiring of such reports from operations contractors of the District, since such contractors would most certainly have been classed with ordnance explosives and chemical warfare contractors had the District not been restricted from furnishing information as to the nature of the work.

2.12

~~SECRET~~

SECTION 3 - PUBLIC SAFETY PROGRAM.

3-1. General. The two District-operated towns, Richland, at the Hanford Engineer Works, and Oak Ridge, at the Clinton Engineer Works, required broad public safety programs embracing safety in public places, school safety and home safety.

3-2. Traffic Safety.

a. Traffic Engineering. Because of the large number of employees commuting by automobile at the Clinton and Hanford Engineer Works, trained traffic engineers were employed to coordinate traffic planning, to study the causes of traffic congestion and accidents, and recommend measures for their elimination. Standard highway signs and signals were erected and, to the extent economically justified, roadway facilities were designed or re-designed for maximum safety. Conditions which caused accidents have been revealed by analyses of reports of accident investigations, and corrective measures were promptly taken.

(1) Traffic Counts. The periodic traffic counts taken under the supervision of the Traffic Engineer served as an important basis for handling and routing traffic, as well as the planning of economical paving and development of existing roads and the planning of future road facility requirements. A typical gate count summary is shown as App. B 2 and intersectional flow diagram as App. A 1.

(2) Elimination of Congestion. Although traffic engineering is principally directed at the elimination of hazards, the profits of traffic engineering in terms of elimination of congestion and the saving of workers' time are often more easily measured than

are the accidents prevented. For example, at Clinton Engineer Works a novel plan for handling traffic at two bridges entirely eliminated congestion which had been delaying about 4000 workers' automobiles for thirty minutes each morning and night. A two-way radio patrol car stationed at the far end of each bridge and the two-way radio in the guard house at the reservation end of each bridge provided the necessary communication so that traffic could move in the same direction in both lanes during most of the rush hours, and yet one lane could be used periodically for opposing traffic by signals from the radio control posts. Later standard traffic signal heads were used for the same purpose. This single improvement made a notable contribution to employee morale.

In the early days of construction, many work roads grew "like Topsy". When these roads were inadequate to handle a large volume of truck traffic around plant construction sites, the traffic engineer stepped in, designed an efficient road layout, and speeded up the job. To handle tremendous rush-hour traffic volumes at certain critical intersections an ingenious layout was developed with separate lanes for continuous right turns connecting two or more legs of the intersections, similar in purpose to the continuous turn features of the conventional "clover-leaf" overpass. Many main roads were designed for three lanes of traffic; two lanes were used to handle the in-bound traffic in the morning, and then in the evening two lanes were assigned to out-bound traffic. Large signs were posted establishing the hours for this special assignment of the center lane. Drivers quickly learned to make maximum use of the available lanes.

~~SECRET~~

b. Motor Vehicle Driver's Permits. Government motor vehicle driver's permits have been required by the District for all drivers of Government vehicular equipment, including contractors' employees (See App. E 6).

(1) Tests. At the Clinton and Hanford Projects where relatively large numbers of government vehicles were operated, the full program of written tests on regulations and safe practices, reaction and vision tests, road tests, and enclosed area tests, established by the Office of the Chief of Engineers, was used. (See App. E 3 and 4). Every precaution has been taken to insure that drivers of Government-owned motor vehicle equipment were thoroughly qualified for safe operation.

(2) Records. A continuous record was maintained for each driver showing his grades in the tests, any traffic violations of which he was convicted, and pertinent data on any accidents in which he may have been involved (See App. D 3). These records were particularly valuable when a driver successively worked for two or more contractors as the job progressed. The records have been used, first, as the basis for interview and possibly selective training but, last, for driver discipline in the form of permit suspensions or lay-offs in the few cases where drastic action was necessary.

c. Enforcement of Traffic Regulations. Auxiliary Military Police and Military Police forces have been responsible for the enforcement of traffic regulations within the Clinton and Hanford Engineer Works. Because of the secrecy of the work, use of existing local traffic law enforcement agencies within the bounds of these two instal-

3.3

~~SECRET~~

~~SECRET~~

lations was not practicable. Special traffic violation review boards consisting of Army officers were appointed and authorized by the District Engineer to hear cases of traffic violations and make recommendations to prevent further operation of vehicles within the limits of the installations by persons showing willful disregard for the safety of others.

(1) Traffic Code. A Traffic Regulation Code was prepared at Clinton Engineer Works and given wide distribution so that all concerned were fully informed of the requirements (See App. C 12). The Regulations conform to those of the Uniform Vehicle Code now adopted in most states. Thus residents were not subjected to unusual regulations, but were required to conform with rules similar to those employed in their home towns.

(2) Police Training. Experts from the National Safety Council and International Association of Chiefs of Police have conducted special training schools for Clinton and Hanford traffic police. A description of police training and operations will be found in Book I, Volume 14, Intelligence and Security.

(3) Accident Investigation. Traffic accident investigation and reports have been made by the police forces, trained squads being used for this purpose. Safety and police personnel jointly designed a motor vehicle report form for use by investigators at Clinton Engineer Works, modeling it after the Uniform Traffic Accident Report of the National Safety Council (See App. D 4). This new form, particularly suited to Government needs, is being considered for adoption as a Federal standard by a committee of the Federal Inter-Departmental

~~SECRET~~

~~SECRET~~

Safety Council.

d. Government Vehicle Inspection. The Corps of Engineers' requirement that all government vehicles be inspected weekly or at 1000-mile intervals was enforced. Government vehicles could not obtain gasoline or other services unless a valid safety inspection sticker was affixed to the vehicle windshield. As available equipment became worn, this safety precaution became essential to safe, efficient vehicle operation.

3-3. Community Safety. Because of security restrictions, full responsibility for providing adequate safety for residents of the communities within the areas of the Clinton and Hanford Engineer Works was necessarily assumed by the District. This takes the forms of:

a. School Safety. Safety education has been made an integral part of the elementary and high school curricula at the Clinton and Hanford Engineer Works. This was in the hands of a School Safety Committee with one or more representatives from each of the schools. The Safety Branch supplies safety materials, visual aids, etc. (See App. G) and acts in an advisory capacity. School Safety Patrols have been set up in all elementary schools, drilled and trained by members of the community police forces. The Standard Rules for Operation of School Safety Patrols (See App. G) developed by the National Congress of Parents and Teachers and other national education groups governed the operations of the patrols. A safety poster contest with substantial awards brought over 700 entries. The posters were displayed at the Clinton Engineer Works Safety Show. (See App. E 5). An automobile driver training course for high school students of proper age has been

3.5
~~SECRET~~

~~SECRET~~

a part of the high school curriculum.

b. Home Safety. The home accident problem has been a difficult one to cope with as there are no definite controls over the actions of individuals in their own homes, even when such homes are Government-owned. A high degree of safety was built into homes at both installations: Stairs were largely eliminated, design was modern, heating equipment was automatically controlled, fire place screens were supplied, etc. Continuous programs were maintained to keep alive public interest in safety. The causes of home accidents were studied and appropriate corrective action was taken. The co-operation of community organizations was enlisted in educational work.

(1) Model Trailer Home. A Model Trailer was developed by the Fire Prevention Bureau of Oak Ridge with the aid of women's organizations, and was used in demonstrations at trailer camps. It included practical displays of fire and accident hazards and measures for their correction or prevention. (See App. F 4).

(2) Model Safe Homes. Model safe homes were established at Hanford and Clinton Engineer Works. Safe conditions and safe practices were placarded throughout the buildings, and hostesses gave narrative demonstrations of the safe operation. It has been estimated that approximately three-fourths of the housewives attended these demonstrations. Photographs of the Clinton Engineer Works Safe Home are included as App. E 6.

(3) Home Safety Courses. The standard American Red Cross home safety course was conducted at Hanford Engineer Works with over 400 housewives in attendance.

~~SECRET~~

c. Recreation Safety. Theatres, recreation halls, and other recreational facilities were included in the scope of the District's safety program. All public buildings were periodically surveyed for fire and other hazards and adequacy of exit facilities. Tents housing skating rinks and similar enterprises were required to be flameproofed. Floor foundations in tents were checked for safety. Bleachers were inspected. The qualifications of life guards at swimming pools were established. Much of the direct safety work was performed by a safety inspector on the staff of the Recreation and Welfare Association.

Tot playgrounds were established at numerous locations throughout the town. Swings, teeter-boards, and other equipment reduced the temptation for children to play in or near the streets. There was one serious accident at one of these tot playgrounds - a little girl was killed when a swing overturned after its anchors had worked loose. An inspection system was instituted which insured perfect maintenance of such equipment and prevented a recurrence. Despite this accident, the playgrounds were probably instrumental in saving many children's lives by keeping them out of the way of heavy traffic.

d. National Safety Council Surveys. The community safety problems of Clinton and Hanford Engineer Works have been periodically surveyed by National Safety Council experts on home, school and traffic safety, who made comprehensive recommendations (See App. G and H 7). Approximately 95 percent of their recommendations have been adopted. Portions of the correspondence between the President of the National Safety Council and the District Engineer (App. C 13) clearly indicate that the national organization considered the community safety programs at Clinton Engineer Works and Hanford Engineer Works to be progressive,

~~SECRET~~

up-to-date, and effective. The Council was eager to participate in these attempts to build and develop safety in these communities "from the ground up".

e. Community Safety Shows. Extensive safety shows have been conducted at both installations. These included exhibits on industrial, off-the-job, and home safety. Entertainment features were included to stimulate interest and attract attendance. Photographs of the exhibits at the Clinton Engineer Works show, attendance 8000, are presented in App. E 7. Photographs of the Hanford Engineer Works show, where mass entertainment features boosted attendance to 20,000, are included as App. E 8. The Safety Branch initiated a Child Activities Group at Clinton Engineer Works, which sponsored Saturday morning shows to keep 1200 trailer camp children off the streets and constructively amused (App. E 9).

f. Off-the-Job Safety. Not only in the two major communities at Clinton and Hanford Engineer Works, but also at other smaller projects, every effort has been made to promote the safety of workers during their off-duty hours. A worker accidentally disabled off the job was just as much lost to the war effort as was one hurt on the job. While home demonstrations could be provided only at the two government communities, posters and other educational materials were used at other areas.

3-8
~~SECRET~~

~~SECRET~~

SECTION 4 - OTHER SAFETY ACTIVITIES.

4-1. Safety Materials and Equipment.

a. Literature. Through the Office of the Chief of Engineers, posters, educational materials, technical pamphlets, and training films were provided each month for use by Government and contractor personnel. Posters were widely used, not only for their inspirational effect, but also to supply specific details or place special emphasis on the hazards currently contributing most frequently to accident occurrence (See App. F 8). Dashboard cards with safety hints were available for vehicles (See App. F 9). The monthly magazinettes, "Safe Driver" and "Safe Worker", combining humor and safety, were distributed (See App. F 10). Lists of available materials have been circulated to contractors and Area Offices and selections for current and applicable subjects were submitted to the District Office for procurement. The District Safety Branch maintained an extensive library of technical literature, for, while each contractor had the standard safety engineering reference manuals, the problems encountered in District work covered such a wide range of hazards that a complete, central library was most economical.

b. Equipment. Equipment for determining the presence and concentrations of flammable, injurious, and toxic substances has been maintained in the District Office for use at all Areas by Government and contractors' safety engineers. Lists of this available equipment were circulated periodically to District projects.

4.1

~~SECRET~~

~~SECRET~~

4-2. Periodic Meetings of Safety Personnel.

a. Local Meetings. The key personnel of the District Safety and Accident Prevention Branch and the official safety representatives of the contractors at Clinton Engineer Works periodically met to discuss developments of general interest, co-ordinate safety efforts, and plan new activities. These meetings have been held bi-weekly, the operations and construction personnel meeting together and separately at alternate meetings. Sample minutes of these meetings are shown in App. C 14.

b. National Conferences. Key members of the District safety staff attended the national conferences of safety personnel conducted by the Office of the Chief of Engineers. These were held annually in conjunction with the National Safety Congress. The meetings served a three-fold purpose: Manhattan District and Area safety personnel had the opportunity of gathering as a group for discussion of common problems, District personnel benefited from the discussions of Corps of Engineers work and problems, and the staff had the opportunity to hear nationally-prominent speakers in their respective fields. District representatives also attended the Safety Training Conferences and other meetings called by the Office of the Chief of Engineers.

4-3. Medical Care. A comprehensive industrial medical service, fulfilling the requirements of Section 8302.03, Safety Requirements for Excavation, Building, and Construction (App. C 3), was developed. This not only insured prompt and adequate care for job-connected injuries, but also made possible an employee welfare service which was a powerful factor in keeping workers at their daily tasks. The Oak Ridge Hospital

4.2

~~SECRET~~

~~SECRET~~

was so staffed and equipped that it provided an excellent medical service on occupational and other accidental injuries. A full description of medical services will be found in Book I, Volume 7 of the History.

4-4. Contests. The spirit of competition can often be used to stimulate the safety program. American Industrial Transit conducted a contest in which its various terminals and Off-Area bus operations competed for low accident rates. The J. A. Jones Construction Company conducted a safety letter contest for the wives of employees. Many employees entered the monthly contests for safety limericks sponsored by the National Safety Council in conjunction with the Council's safety calendars which had been widely distributed. The American Legion and the Junior Chamber of Commerce sponsored suggestion contests on community safety.

4.3

~~SECRET~~

SECTION 5 - ACCOMPLISHMENTS.

5-1. Occupational Safety Record. The occupational injury rates of the Manhattan District have averaged 62 percent below comparable rates for private industry.

a. Magnitude of the District Safety Program. The number of employee-hours of occupational exposure covered by the District safety program in the 30 months from January 1943 through June 1945 was as follows:

Construction	345,842,753
Operations	185,650,095
Government	<u>16,390,948</u>
Total	547,883,796

See App. B 3 for details.

b. Methods of Comparison. The only tangible and reliable measure of the effectiveness of any safety and accident prevention program is the extent to which it prevents loss of productive labor from accidents, and disabling injuries and deaths among the persons it is designed to protect. In order to evaluate the safety record for a project or program of work, two types of appraisals are generally made:

(1) The trend of injury rates as work progresses. (See sub-paragraph d).

(2) Comparison with the injury rates of other groups or organizations doing similar types of work. (See sub-paragraphs e and f).

c. Units of Comparison. In accordance with the American Standards Association Method of Compiling Industrial Injury Rates (ASA Standard Z 16.1) used by the National Safety Council, nationally known insurance companies, the Corps of Engineers, the United States Department of Labor and other organizations compiling and comparing safety records, the occupational safety record of the District has been expressed in the following terms:

(1) Frequency Rate. The number of lost-time disabling injuries from occupational accidents per million employee-hours worked.

(2) Severity Rate. The number of days of work lost from occupational accidents per thousand employee-hours worked. Fixed time charges of the American Standard Method were used for deaths and permanently disabling injuries, a few examples being as follows:

<u>Injury</u>	<u>Penalty</u>
Death	6000 days of work lost
Permanent total disability	6000 days of work lost
Loss of one eye	1800 days of work lost
Loss of one finger	300 days of work lost

(3) Fatality Rate. Number of deaths from occupational accidents per million employee-hours worked.

(4) Disabling Occupational Injury. Any injury arising out of and in the course of employment which resulted in death, permanent disability, or inability to return to work on the day following the accident or any subsequent day. In accordance with ASA Standard Z 16.1, the rulings of State Workmen's Compensation Commissions were followed to determine proper classification of borderline cases.

d. Trend of District Injury Rates. Comparisons of the District safety records for 1944 and the first six months of 1945 with the rates for 1943 show substantial overall improvements in the latter periods. The percentage ^{differences} reductions in rates from 1943 were as follows:

<u>Employees of:</u>	<u>Frequency Rate</u>		<u>Severity Rate</u>		<u>Fatality Rate</u>	
	<u>1944</u>	<u>6 Mo. '45</u>	<u>1944</u>	<u>6 Mo. '45</u>	<u>1944</u>	<u>6 Mo. '45</u>
Construction Contractors	-23%	-37%	-32%	-59%	-36%	-55%
Operations Contractors	-31%	-42%	+86%	+68%	*	*
Government	+13%	-72%	+1400%**	-40%	*	0%

* 1943 rate was zero; percentage increase cannot be calculated.

** Caused by one fatality of a Government employee assigned to an operating contractor.

The actual rates for these periods are shown in sub-paragraphs e and f below and in App. A 2 through 5 and B 3. The 1943 operations severity rate was extremely low, only one-fourth the national rate, partly because the bulk of the operations employees were in training rather than actual production. The 1944 and 1945 operations severity rates, although representing increases from 1943, are still low.

~~SECRET~~

e. Comparisons of District Construction Injury Rates. Comparisons of the Manhattan District's construction contractors' safety record (App. B 3) with those of other comparable groups are as follows:

	<u>Frequency Rate</u>			<u>Severity Rate</u>			<u>Fatality Rate</u>		
	<u>1943</u>	<u>1944</u>	<u>6Mo'45</u>	<u>1943</u>	<u>1944</u>	<u>6Mo'45</u>	<u>1943</u>	<u>1944</u>	<u>6Mo'45</u>
Manhattan District	8.43	6.50	5.31	2.08	1.42	0.85	.22	.14	.10
Corps of Engineers, New Military Const.*	14.29	10.51	7.02	2.74	2.50	#	.34	.33	.20
Private Construction Reported to:									
The National Safety Council	49.87	23.02	##	5.43	2.65	##	.65	.31	##
U.S. Dept. of Labor**	26.06	27.70	##	3.06	3.68	##	.31	.44	##

* Source: Office of the Provost Marshal General.

** Source: Private companies' reports to the Bureau of Labor Statistics, U. S. Department of Labor. Severity rate recalculated on standard basis.

Not recorded. ## Not yet available.

5.4

~~SECRET~~

f. Comparison of District Operations Injury Rates. It is difficult to evaluate properly the injury rates for operation contractors of the Manhattan District (See App. B 3) because of the uniqueness of the District's work. However, the generally comparable rates, based on latest data available, are as follows:

	Frequency Rate			Severity Rate			Fatality Rate		
	1943	1944	6Mo '45	1943	1944	6Mo '45	1943	1944	6Mo '45
Manhattan District	11.75	8.09	6.78	.28	.52	.47	.00	.03	.05
Ordnance Department*	8.00	6.50	4.30	.68	#	#	.08	.06	.08
Chemical Warfare Serv**	26.20	13.80	7.80	#	#	#	.33	.08	.60
National Safety Council Members**:									
Chemical Industry	10.10	10.24	##	1.12	.91	##	#	.08	##
All Industries	14.50	14.46	##	1.20	1.21	##	.10	.10	##
U.S. Dept. of Labor***									
All Manufacturing	20.04	18.40	##	1.12	1.07	##	.08	.08	##

* Source: Office of the Provost Marshal General.

** Source: Private companies' reports to the National Safety Council.

*** Source: Private companies' reports to the Bureau of Labor Statistics, U. S. Department of Labor. Severity rate recalculated on standard basis.

Not recorded. ## Not yet available.

g. Savings Effected by the District Safety Program. The savings in lives, disabling injuries, and employee-days of work effected by the Manhattan District safety program can be estimated from the differences between the recorded losses for the District from January 1943 through June 1945 and the losses which would have resulted if the

~~SECRET~~

District's rates had been the same as the national average rates recorded by the U. S. Department of Labor. The details of these calculations are shown in App. B 4. The savings effected by the District safety program in 30 months were:

94 Lives.

9,200 Disabling Injuries.

814,000 Employee-days of Work.

h. Insurance Savings. Under the War Department insurance rating plan, District contractors paid only 50 percent of the standard manual rates for workmen's compensation insurance. Sizeable refunds of amounts paid over claims cost and administrative cost have already been received, but the eventual total refunds cannot be predicted at this time. Since injury frequency and severity rates have been far below private industry averages, the safety program may be credited with substantial insurance savings. See Book I, Volume 6, Insurance Program, for analysis of insurance costs and refunds.

i. Detailed District Safety Records. The safety records of the Manhattan District are shown in detail by the following Appendices:

Graphs of Occupational Injury Rates by Quarters, January 1943

Through June 1945:

App. A 2 -- Manhattan District.

App. A 3 -- Clinton Engineer Works.

App. A 4 -- Hanford Engineer Works.

App. A 5 -- Other Areas.

56

~~SECRET~~

Tabulations of Occupational Injury Experience, January 1943
Through June 1945:

App. B 3 -- Manhattan District.

App. B 5 -- Clinton Engineer Works and the Areas.

App. B 6 -- Principal Contractors, Clinton Engineer Works.

5-2. Traffic Safety Record. The community traffic safety record at Clinton Engineer Works can be measured and compared with the records of other cities of comparable size.

a. There were nine deaths due to motor vehicle accidents at Clinton Engineer Works in 1944. This includes occupational deaths resulting from motor vehicle accidents.

b. One commonly used measure of exposure to motor vehicle accidents is the number of motor vehicles registered by residents of a city. It is estimated that the 46,000 residents of Clinton Engineer Works (the approximate average population during 1944) owned and operated about 9,000 vehicles in 1944. In addition, 4,600 were Government-owned. The 11,700 vehicles entering the gates daily, carrying workers coming on the Area, may also be added, because these workers traveled considerable distances while on the Area - far greater distances than those traveled by the average American car-owner in the city of his residence in 1944. These figures show that a total of about 25,300 vehicles operated at Clinton Engineer Works.

c. The nine motor vehicle deaths were equivalent to a rate of 3.6 deaths per 10,000 vehicles. This rate was slightly below the average rate of 3.7 shown by the National Safety Council based on reports of 72 cities of 50,000 to 100,000 population.

~~CONFIDENTIAL~~

d. It is creditable enough that a new community, literally chopping its traffic facilities out of the hills and farmlands, could equal the 1944 record of established communities. When it is considered that most residents of Oak Ridge were issued supplementary gasoline rations due to their dependence on motor vehicles, and that each car in Oak Ridge consequently had a greater exposure to accident involvement, it seems likely that Oak Ridge's traffic safety record was superior to that of the average community.

e. There were five motor vehicle deaths in the first half of 1945, but the number of motor vehicles operated had risen from 1944 levels.

5-3. Quality of Accomplishment. By all the above records and comparisons - of the frequency, severity and fatality rates for both construction and operation, by the computations of savings in lives, injuries and days of work, and by the comparative traffic records, the safety accomplishment of the Manhattan District is shown to be an impressive one. It compares favorably with the records of other organizations and in almost every item it has been improving as the work has progressed.

~~SECRET~~

SECTION 6 - ORGANIZATION.

6-1. Formation. Plans for an adequate safety organization were made during the early development of the Manhattan District program. A safety engineer was first employed in August 1942 and, with the assistance and supervision of a Safety Officer in the District Protective Security Branch, immediately began development of an accident prevention program. Upon completion of organizational plans in November 1942, the safety engineer was transferred to Clinton Engineer Works, where the first major construction was about to start, and there assisted the Officer-In-Charge in putting a construction safety program into effect. At the same time supervision of all District safety activities was placed under the District Safety and Labor Relations Officer.

6-2. Development.

a. June to December, 1943. By June 1943, construction had reached such proportions that a unit known as the Safety-Accident Prevention Section was created to administer all phases of safety for the District and to provide consultants to the Area Engineers and contractors. The District headquarters moved from New York, New York, to Clinton Engineer Works in August 1943. In September 1943 the first of the Resident Safety Engineers was established at the Hanford Engineer Works, where the magnitude of construction warranted the full-time services of a safety engineer. In November 1943 the "Area" status of Clinton Engineer Works was terminated; officers in charge of construction and operation henceforth reported directly to the District Engineer.

~~SECRET~~

To eliminate duplication and simplify control, staff and administrative organizations for the Clinton Engineer Works were combined with those of the District headquarters. Thus the Clinton Engineer Works safety group and the District Safety-Accident Prevention Section were consolidated. The District Safety Engineer served in the dual capacity of a member of the District Engineer's staff for District safety and as the person directly responsible for safety activities at the Clinton Engineer Works. The organization of the District Safety-Accidⁿta Prevention Section on 31 December 1943 is shown in App. A 6. Construction, Industrial, Training, Traffic and Community Units had been formed to care for the Section's varied problems.

b. January to June, 1944. By 30 June 1944 further change and expansion in the Safety-Accident Prevention Section had become necessary in order to keep abreast of activities. (See App. A 7). The District Safety Engineer reported directly to the District Engineer through an Executive Assistant instead of through the District Service and Control Officer. The "Industrial Safety Unit" was renamed the "Operations Safety Unit" to better describe its functions. During the first part of 1944 at Clinton Engineer Works a Safety Advisory Committee of plant workers, Oak Ridge residents, and representatives of contractors and citizens' groups, such as Boy Scouts, Red Cross, and Parent-Teacher Associations, was formed to foster and coordinate non-occupational, community safety activities. At the same time most of the operating functions in the community safety program were made the responsibility of the Oak Ridge town management contractor, the Roane-Anderson Company.

c. July to December 1944. It was found that community safety could be handled more effectively by District safety engineers than by the town management contractor and volunteer workers. Although contributing commendably, Advisory Committee members did not have the necessary time to devote to community safety activities. Therefore, the Committee was dissolved and responsibility for conducting Oak Ridge community safety activities was reassigned to the District Safety Engineer. The District safety organization (renamed "Safety and Accident Prevention Branch") as it existed on 31 December 1944 is shown in App. A 8. Operations Safety and Construction Safety had been grouped together in an Occupational Safety Section; the two phases of accident prevention had many overlapping problems, making it advantageous to combine their immediate direction under one person. A new Public Safety Section coordinated the Traffic and Community Safety Units.

d. January to June 1945. In May 1945 it was decided, after consultation with higher headquarters, that the individual plant operations and the town management at Clinton Engineer Works were of such size and were sufficiently independent in administration to justify the direct assignment of resident safety engineers to the staffs of the Officers-In-Charge. Personnel of the District Safety Branch were assigned to these operations units. (See App. A 9). In addition, the task of administering tests for Government Motor Vehicle Operator's Permits was transferred to the Automotive Transportation Officer.

6-3. Present Organization and Responsibilities. The present organization, responsibilities and functions of the District safety staff are as follows:

a. The District Safety Engineer plans and coordinates accident prevention activities of the District; serves as consulting specialist for the District Engineer; aids and advises Area Engineers, Officers-In-Charge, and contractors in accident prevention programs and assists in control of special and unusual hazards, and enforcement of safety requirements and regulations.

b. The Occupational Safety Section provides consultant services to contractors on occupational problems, cooperates with the District Medical Branch in controlling and preventing occupational disease and health hazards, plans and executes safety programs for Government personnel, assists Area Engineers, Officers-In-Charge, and contractors in the development of effective accident prevention programs for construction and operation activities.

c. The Safety Training and Off-The-Job Safety Section provides consultants for safety training activities, determines training needs, prepares manuals, instruction material and training and testing techniques, and stimulates safety training of administrative personnel. It also plans and assists in the execution of "off-the-job" safety programs, including traffic, home, school and recreational activities.

d. Resident Safety Engineers have been stationed (with two exceptions) at Areas where personnel exposure reached 80,000 man-hours per month (See App. B 1) and with the five Officers-In-Charge at Clinton Engineer Works. They serve full-time as consulting safety specialists to Area Engineers and Officers-In-Charge (who are directly responsible for safety in their respective areas), aid and advise contractors in accident prevention, and maintain liaison with the District Safety

Engineer. The two exceptions have been the Boston and California Areas, where part-time engineers have been serving. In the Boston Area the employee exposure was created by office engineering and clerical personnel. In the California Area, it was agreed between the Area Engineer and the District Safety Branch that, in view of the type of work and the safety program to be established by the contractor, the employment of a full-time resident safety engineer be held in abeyance to determine whether the contractor would reduce injury rates; a steady downward trend in rates to a satisfactory level subsequently indicated that a Government engineer was not needed.

e. Clinton Engineer Works Central Facilities. The Safety and Accident Prevention Branch under the Officer-In-Charge, CEW Central Facilities has had responsibility for overall community safety promotion and education, as well as the direct responsibility for traffic engineering and control, physical safety in public facilities, and employee safety for Central Facilities contractors. The Branch has had Traffic, Community, and Industrial Sections.

f. Hanford Engineer Works. At this installation the Safety Branch has had Occupational, Training and Public Safety Sections with duties similar to those described for corresponding sections above.

6-4. Personnel. The numerical growth and present strength of the District's safety staff, including both the District Safety and Accident Prevention Branch and Area staffs, was as follows:

	<u>31 Dec.</u> <u>1943</u>	<u>30 June</u> <u>1944</u>	<u>31 Dec.</u> <u>1944</u>	<u>30 June</u> <u>1945</u>
Officers	2	1	1	3
Non-commissioned Officers	2	7	6	3
Engineers	21	28	30	25
Inspectors	4	2	4	1
Driver Permit Examiners	7	15	12	13*
Clerical, Administrative	<u>14</u>	<u>19</u>	<u>18</u>	<u>18</u>
District Totals	50	72	71	63

* Assigned to Automotive Transportation Officer.

a. Calibre of Personnel. The District searched far and wide for outstanding safety personnel. Despite the shortage of qualified men, limitations on Government salaries, and questionable post-war security in District positions, men of high calibre were secured. By way of example, the history and qualifications of two of the District staff are outlined briefly in App. C 15.

b. Key Personnel. The following men occupied key positions in the District's safety organization:

<u>Name</u>	<u>Position</u>	<u>Dates</u>
Harvey Mills	District Constr. Saf. Engr.	July 1942 to Nov. 1942
	Resident Safety Engr. CEW	Nov. 1942 to Nov. 1943
James R. Maddy	District Safety Engineer	June 1943 to date.
2d Lt. W.G. Johnson	Ass't District Safety Engr.	Nov. 1943 to Jan. 1944
		Nov. 1944 to date.

~~SECRET~~

<u>Name</u>	<u>Position</u>	<u>Dates</u>
Norman H. Marsden	Safety Engr., District Sec.	July to Nov. 1943
	Chief, Safety Training Sec.	Nov. 1943 to Jan. 1944
	Ass't Dist. Safety Engineer	Feb. to July 1944
	Resident Saf. Engr. M.S.A.	July 1944 to date.
Merton E. Ridge	Traffic Engineer, C.E.W.	Dec. 1943 to July 1944.
	Oak Ridge Safety Director	July 1944 to date.
J. T. Faust	Chief, Operations Saf. Sec.	Aug. 1943 to Dec. 1944
	Chief, Occupational Saf.Sec.	Dec. 1944 to May 1945
	Resident Saf.Engr., X-10 Res.	May 1945 to date.
W.E. Dasmussen	Chief, Constr. Safety Sec.	Mar. 1944 to May 1945.
	Chief, Occupational Saf.Sec.	May 1945 to date.
Earl J. Reeder	Head, Public Safety Section	Feb. to June 1945
	Head, Safety Training & Off-Job Safety Section	June 1945 to date.
Glenn M. Mostetter	Head, Constr. Safety Section	Aug. 1943 to Jan. 1944
	Resident Saf. Engr., H.E.W.	Jan. 1944 to May 1945

The Resident Safety Engineers in the other Areas and other safety engineers are listed in App. G 16.

6-5. Contractors Safety Organizations. While the District safety staff was charged with organizing and directing the program, the day-by-day integration of safety and accident prevention in each worker's activities, and the constant elimination of accident hazards in equipment, buildings and working routines was the responsibility of the contractors. The cooperation of contractors safety organizations with District safety groups has been splendid, and by joint efforts many

6.7

~~SECRET~~

complex and difficult safety problems have been solved and controlled. At no time has it been necessary for the District to resort, or threaten to resort, to contractual powers to enforce safety compliance.

a. Organization. Each contractor followed its normal corporate policy with regard to the organization and organizational placement of its safety staff. However, most contractor safety directors reported to top executives who had broad authority over most, if not all, contract work.

b. Personnel. Prime contractors employing one thousand or more persons (including employees of subcontractors) and contractors engaged in unusually hazardous work were required to employ full-time safety engineers (See App. B 1). The safety directors of the major contractors, that is, those which employed 5000 or more persons, were:

<u>Safety Director</u>	<u>Contractor</u>
L. G. Damer	Carbide & Carbon Chemicals Company
W. F. Hunn	E.I. duPont de Nemours & Co. (NEW Construction)
Jack Brown	E.I. duPont de Nemours & Co. (NEW Operations)
Douglas W. Kelly	J. A. Jones Construction Company
B. T. Barnett	Boane-Anderson Company
J. W. Mensley	Stone & Webster Engineering Company
James M. Brown	Tennessee-Eastman Corporation.

6-6. Cost of the Safety Program. Not all Areas and contractors have maintained safety cost accounts. However, direct safety expenditures can be roughly estimated from the sample cost figures available for certain Areas and contractors. The total Government and contractor expenditures specifically for safety activities up to 30 June

~~SECRET~~

1945 amounted to approximately \$2,800,000 (See App. H 8). This was equivalent to about \$1.00 per month per employee.

6-7. Assistance from Government Agencies and Other Organizations.

The Manhattan District received the finest cooperation from, and is greatly indebted to, a number of individuals, governmental agencies, and other organizations for assistance in solving the varied accident prevention problems with which it was faced. Prominent among these were:

a. Office, Chief of Engineers. The Safety and Accident Prevention Division, Office of the Chief of Engineers, has maintained continuous liaison with the Safety Branch of the Manhattan District. Standards, requirements, special studies and research and many activities have been developed or adapted for the District. Mr. L. A. Blanchard, Chief of the Division, has served as consultant to Major General L. E. Groves and has advised the District Safety Branch in matters of organization, personnel, program, special activities, and safety training.

b. National Safety Council. The Council furnished "on-the-site" safety surveys and technical advice on traffic, home and school safety at Hanford and Clinton Engineer Works, recommended qualified safety engineers for employment by the District, supplied engineering consultation, and served as supplier of safety promotion materials. A Council survey report is attached as App. G. For other, similar reports see App. H 7.

c. American Red Cross. The American Red Cross supplied instructors and material for first aid training of Richland and Oak Ridge community groups, and plant police and firemen, and for home safety courses.

6.9
~~SECRET~~

~~SECRET~~

d. International Association of Chiefs of Police. The I.A.C.P. furnished an instructor for the training of Clinton Engineer Works police in traffic control techniques.

e. U. S. Department of Interior. The Bureau of Mines provided instructors to train Government and contractors employees. A special course, "Safe Handling of Toxic and Inflammable Substances", was conducted by the Bureau in December 1944 for the benefit of 155 District and contractor employees.

f. U. S. Department of Labor. The U. S. Department of Labor, jointly with the University of Tennessee and the Washington State Department of Labor, provided courses known as "Basic Industrial Safety Engineering" and "Advanced Industrial Safety Engineering" for the benefit of 229 District and contractor personnel.

~~SECRET~~

MANHATTAN DISTRICT HISTORY

SAFETY PROGRAM

APPENDIX "A"

CHARTS AND GRAPHS

<u>No.</u>	<u>Title</u>
1	Sample Intersection Traffic Flow Diagram, Emory Valley and Sawmill Roads, 5 April 1944, 5:00 to 5:50 p.m.
	Occupational Injury Rates, January 1943 Through June 1945, by Quarters:
2	Manhattan District.
3	Clinton Engineer Works.
4	Hanford Engineer Works.
5	Other Areas.
	Manhattan District Safety Organization:
6	31 December 1943.
7	30 June 1944.
8	31 December 1944.
9	30 June 1945.

Number of vehicles
interacted in 15
minute periods.

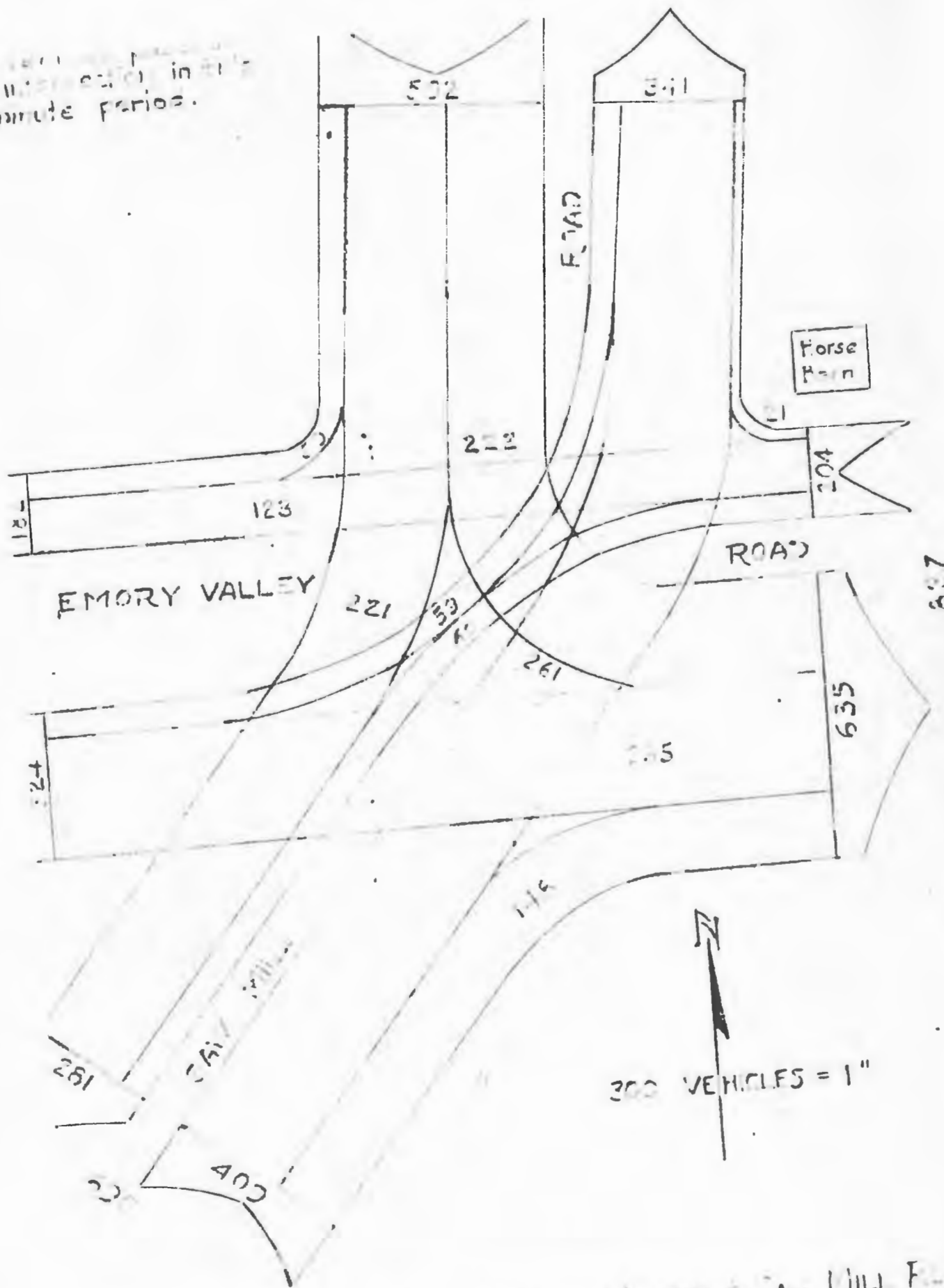

Count of vehicles at Emory Valley & Fair Hill Rd.
April 5, 1944 - 3:00-5:00 P.M.

~~CONFIDENTIAL~~

OCCUPATIONAL INJURY RATES — MANHATTAN DISTRICT

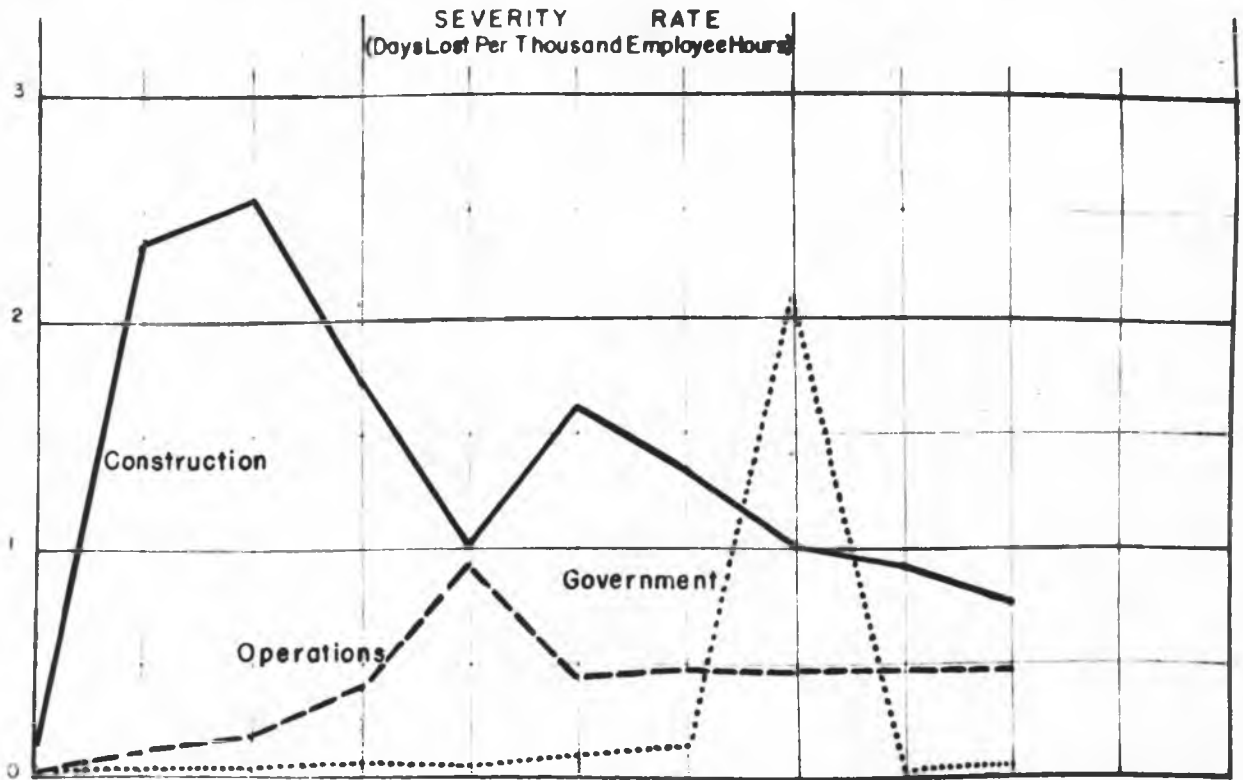
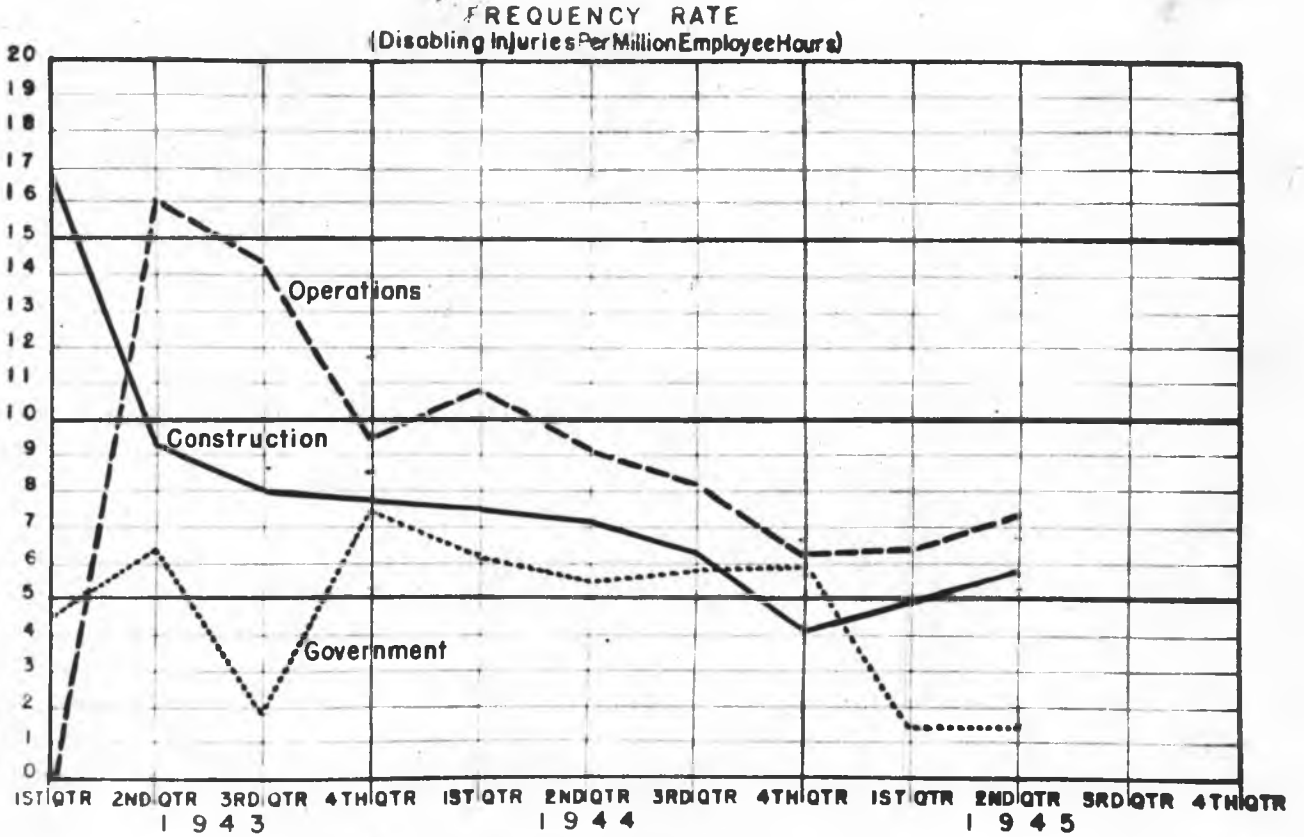

Employee Hours Exposure	1943	1944	1945
Construction Employees	88,287,680	206,901,622	50,653,451
Operations Employees	12,599,964	95,221,977	77,828,154
Government Employees	3,109,685	9,125,732	4,155,531

~~CONFIDENTIAL~~

~~CONFIDENTIAL~~

OCCUPATIONAL INJURY RATES — CLINTON ENGINEER WORKS

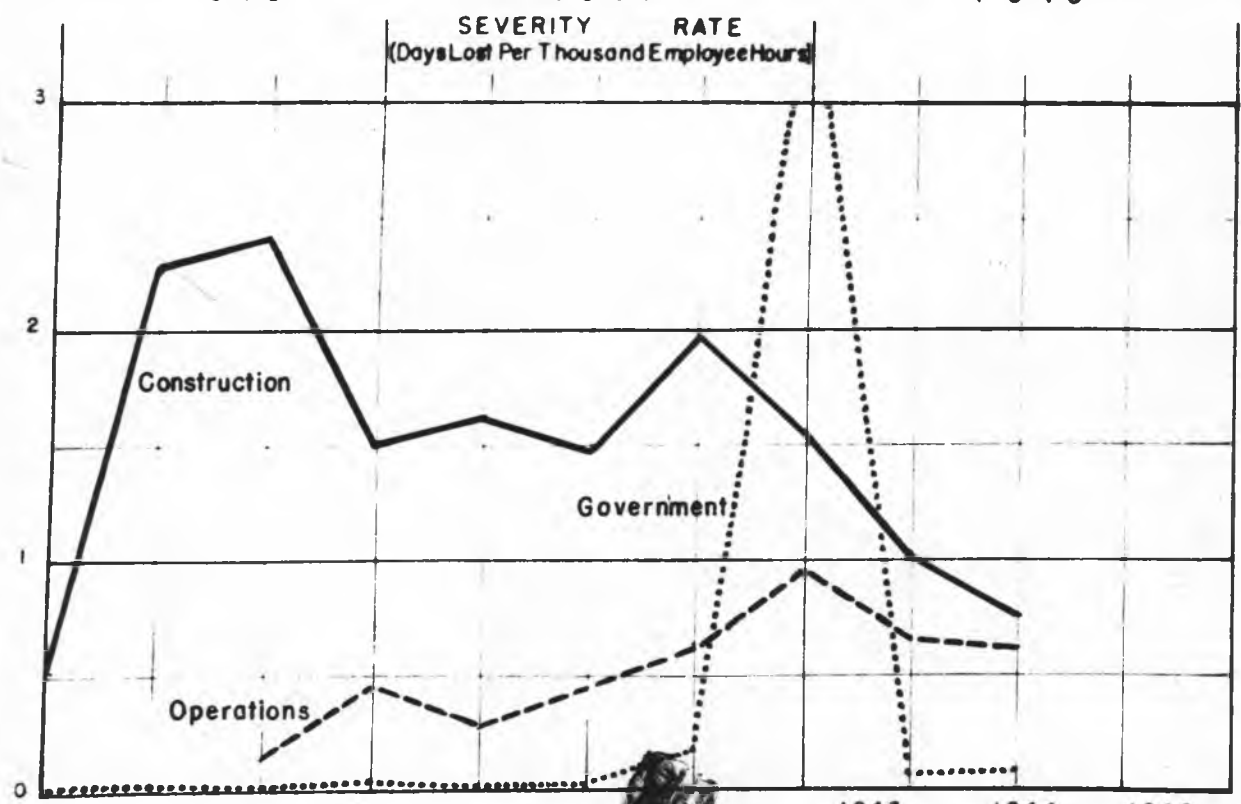
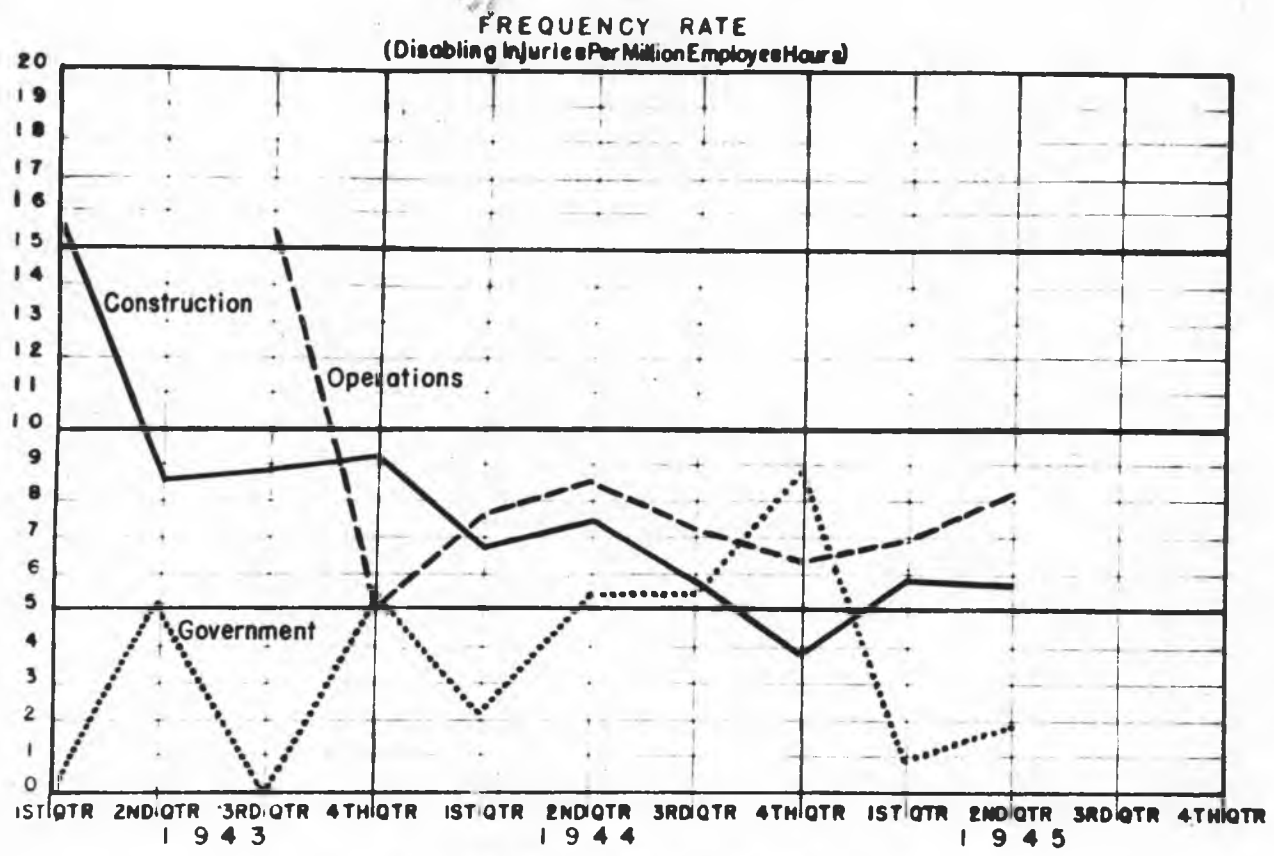

Employee Hours Exposure	1943	1944	1945
Construction Employees	55,737,651	100,407,469	44,246,803
Operations Employees	4,457,322	60,980,845	52,070,374
Government Employees	1,707,255	4,178,121	2,128,902

~~CONFIDENTIAL~~

~~CONFIDENTIAL~~

OCCUPATIONAL INJURY RATES — HANFORD ENGINEER WORKS

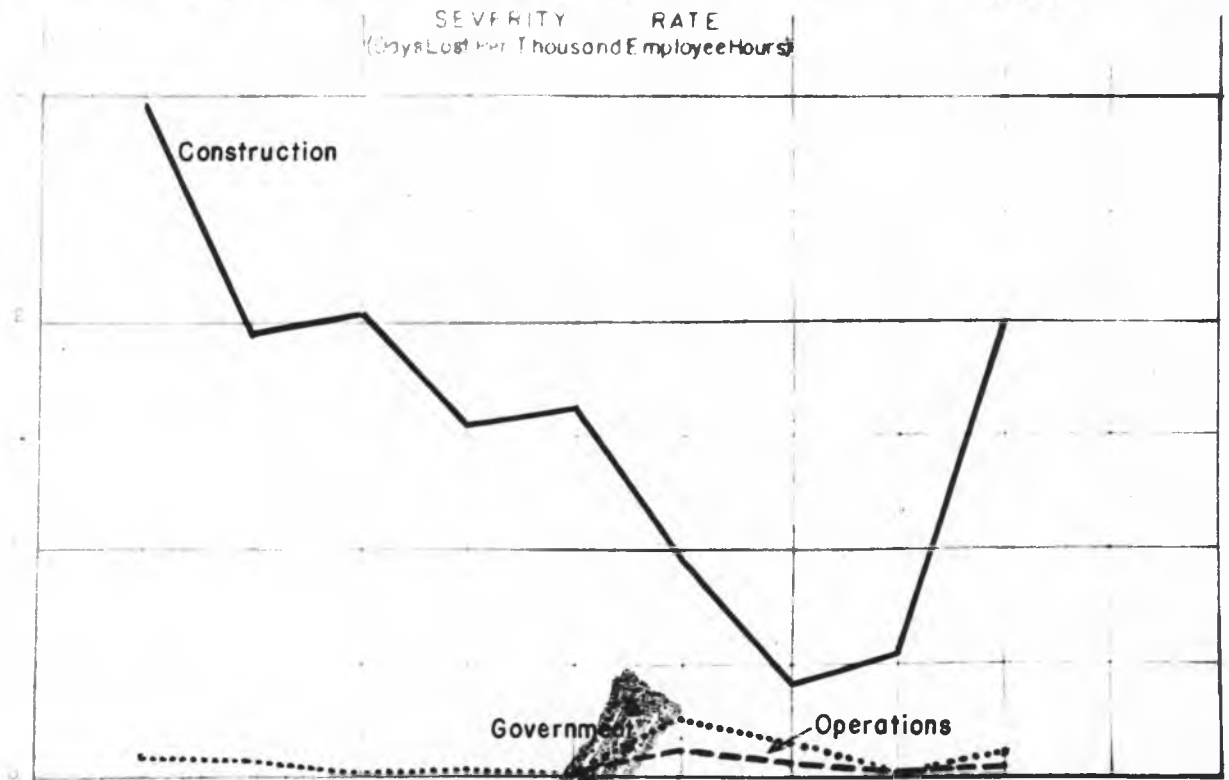
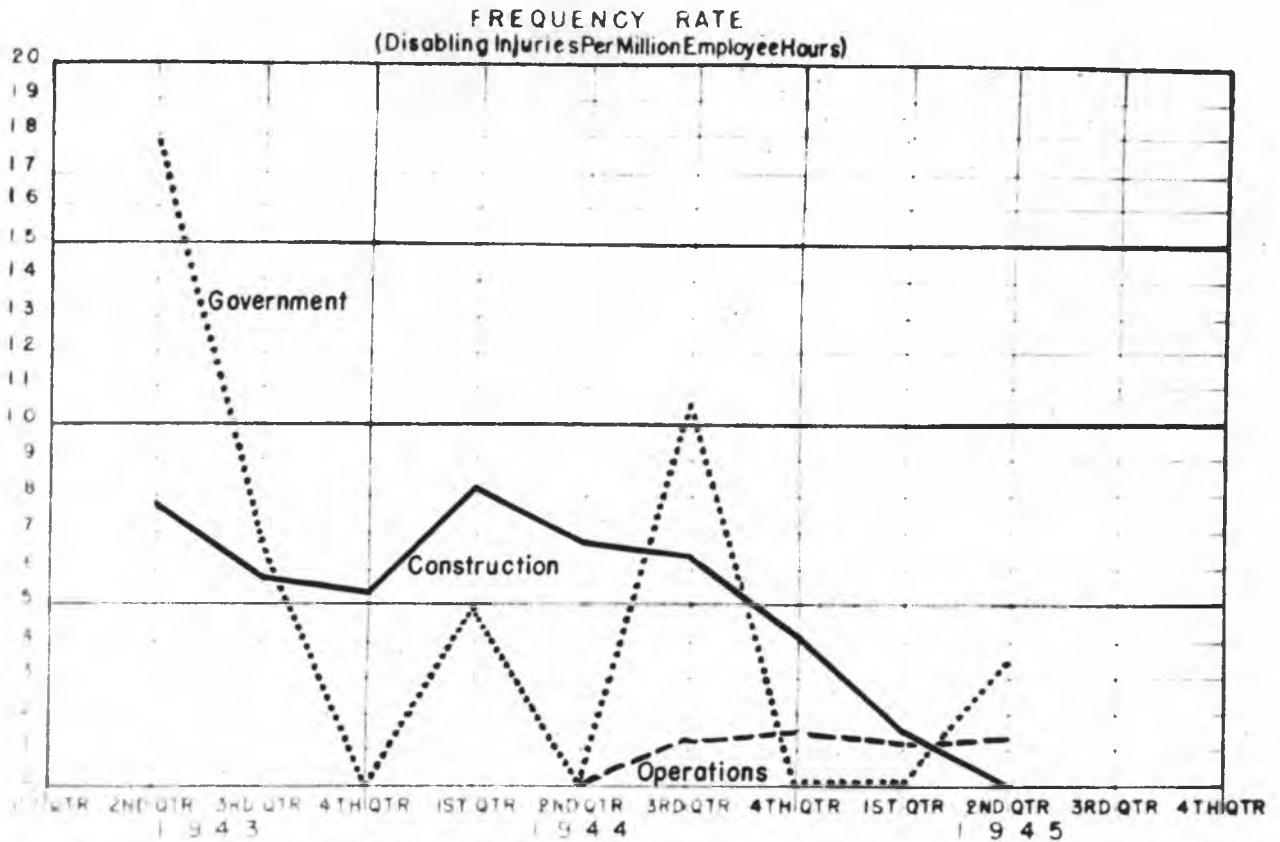

Employee Hours Exposure	1943	1944	1945
Construction Employees	22,711,761	97,277,789	6,026,527
Operations Employees	5,505	5,348,173	6,900,456
Government Employees	391,711	1,217,858	621,654

~~CONFIDENTIAL~~

~~CONFIDENTIAL~~

OCCUPATIONAL INJURY RATES — DISTRICT EXCEPT G.E.W. AND H.E.W.

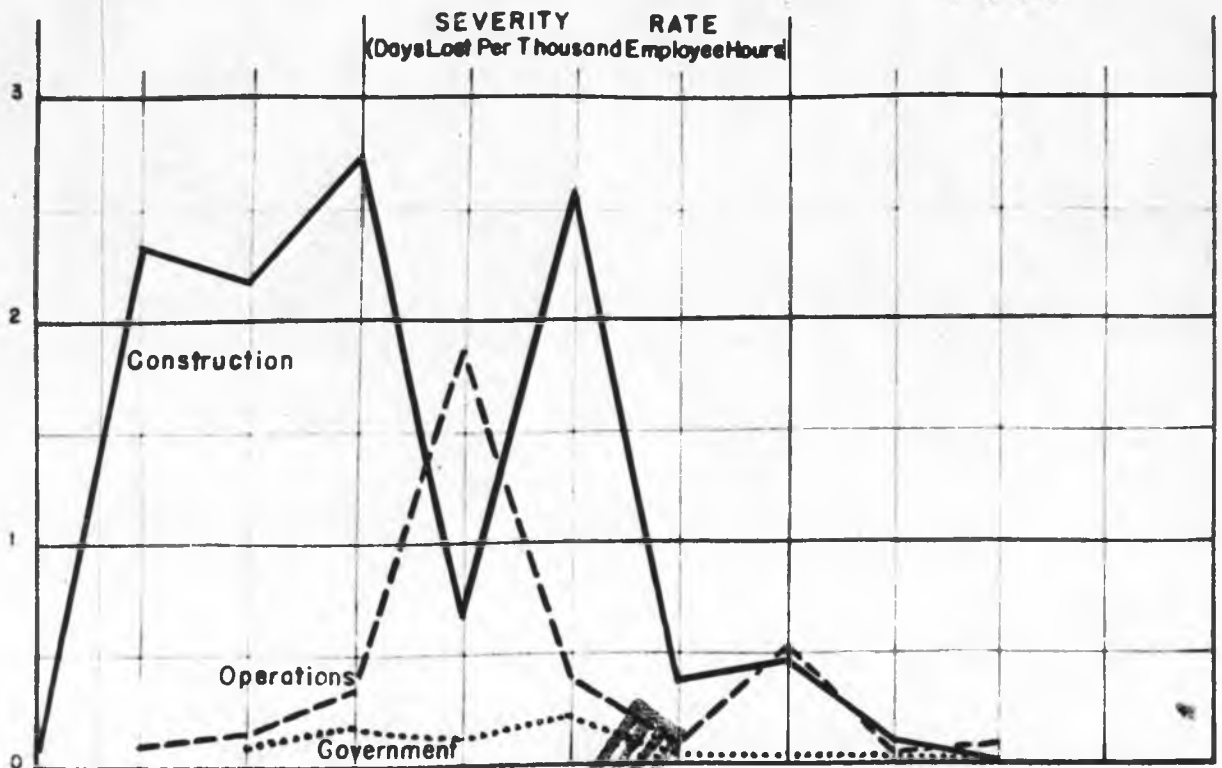
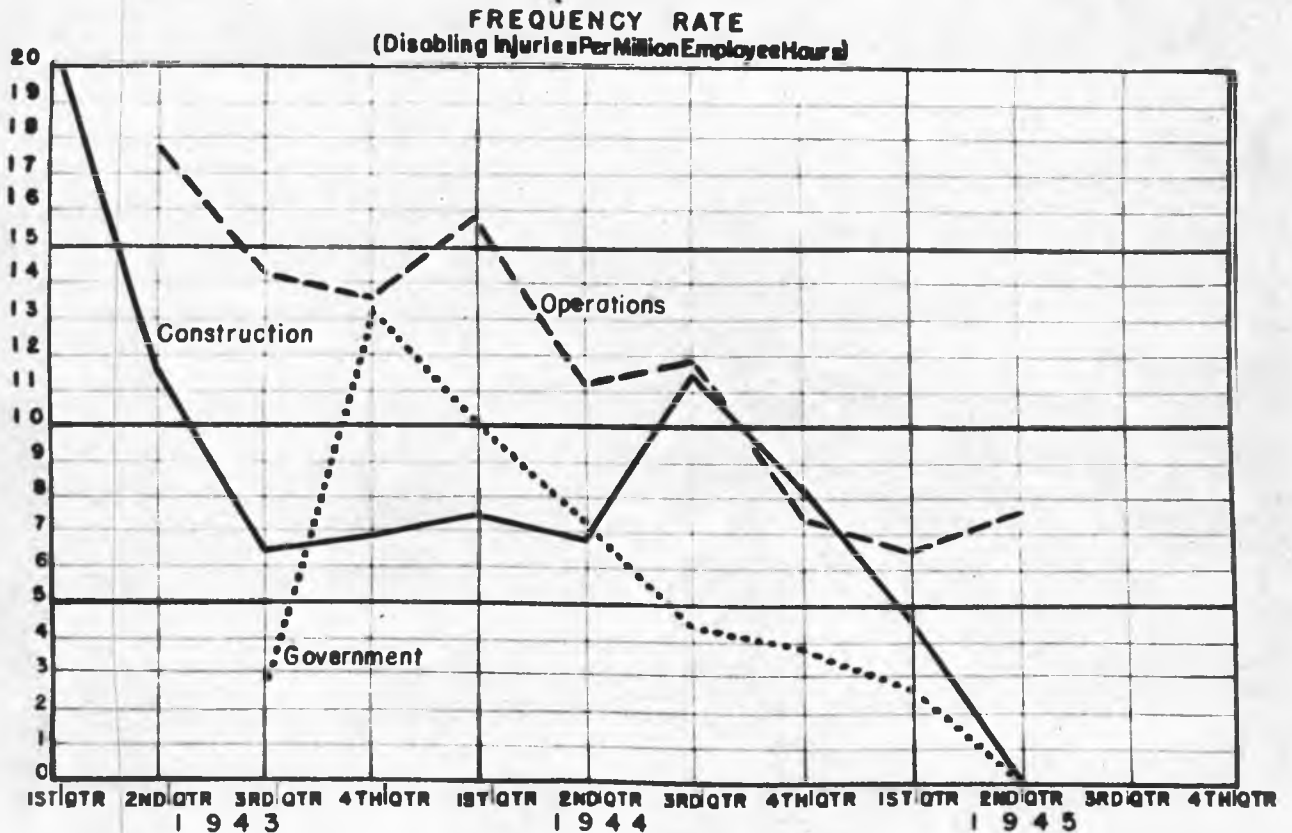

Employee Hours Exposure	1943	1944	1945
Construction Employees	9,838,268	9,216,364	380,121
Operations Employees	8,137,137	28,892,959	18,857,324
Government Employees	1,010,719	3,729,753	1,404,975

~~CONFIDENTIAL~~

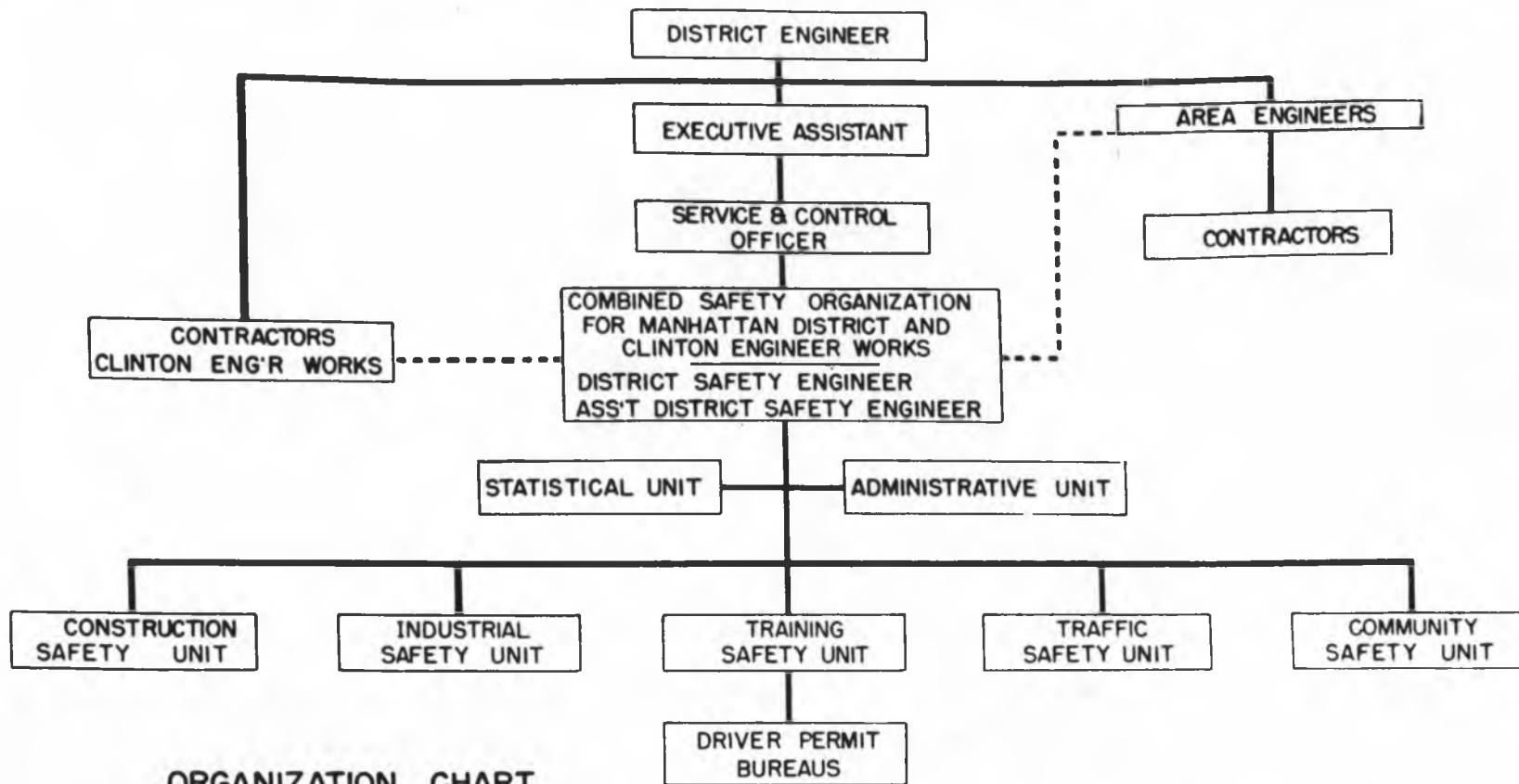

ORGANIZATION CHART
 MANHATTAN DISTRICT SAFETY
 and
 ACCIDENT PREVENTION SECTION
 31 DECEMBER 1943

DIRECT AUTHORITY _____
 ADVISORY OR INDIRECT CHANNELS.....

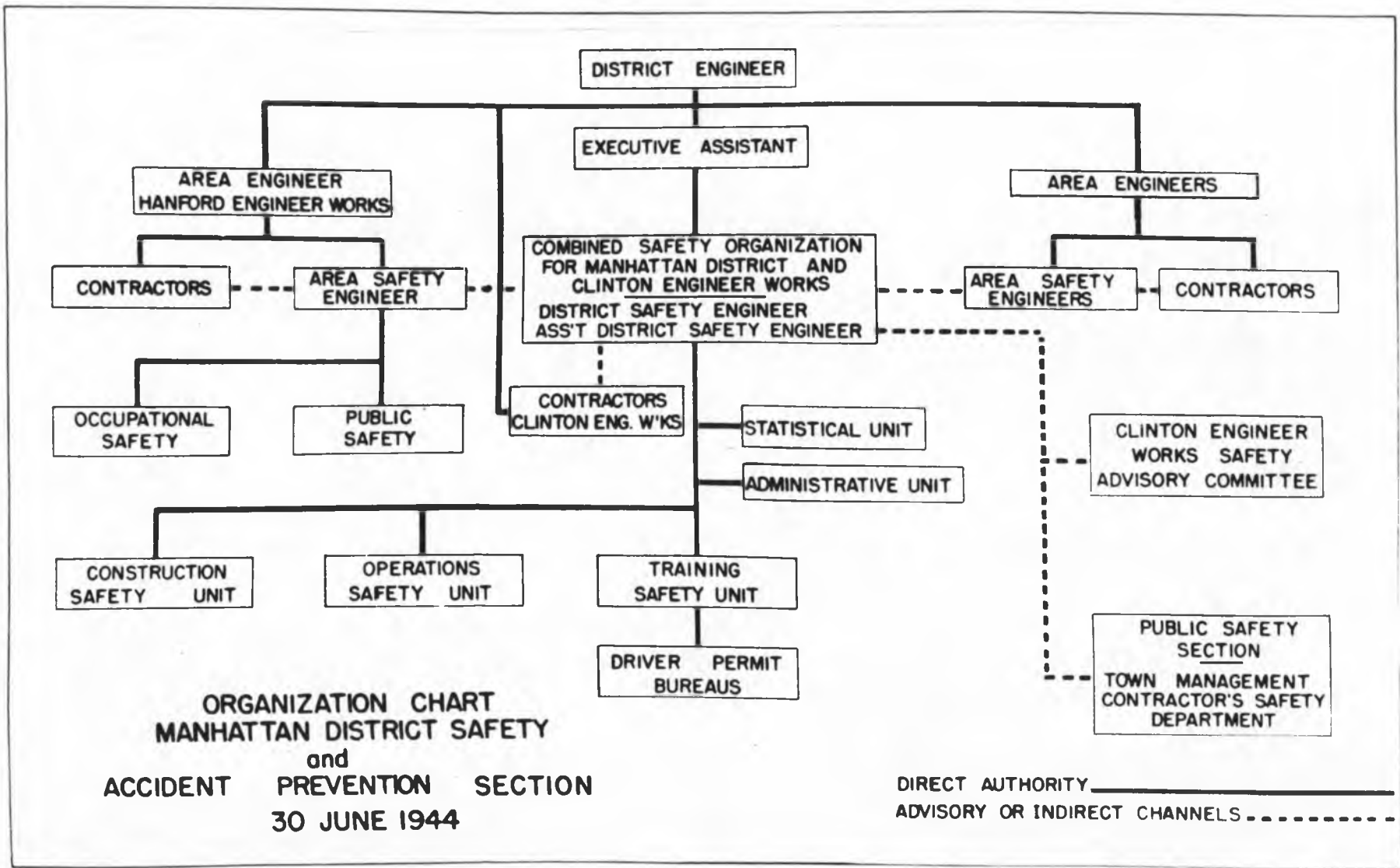

ORGANIZATION CHART
 MANHATTAN DISTRICT SAFETY
 and
 ACCIDENT PREVENTION SECTION
 30 JUNE 1944

DIRECT AUTHORITY _____
 ADVISORY OR INDIRECT CHANNELS - - - - -

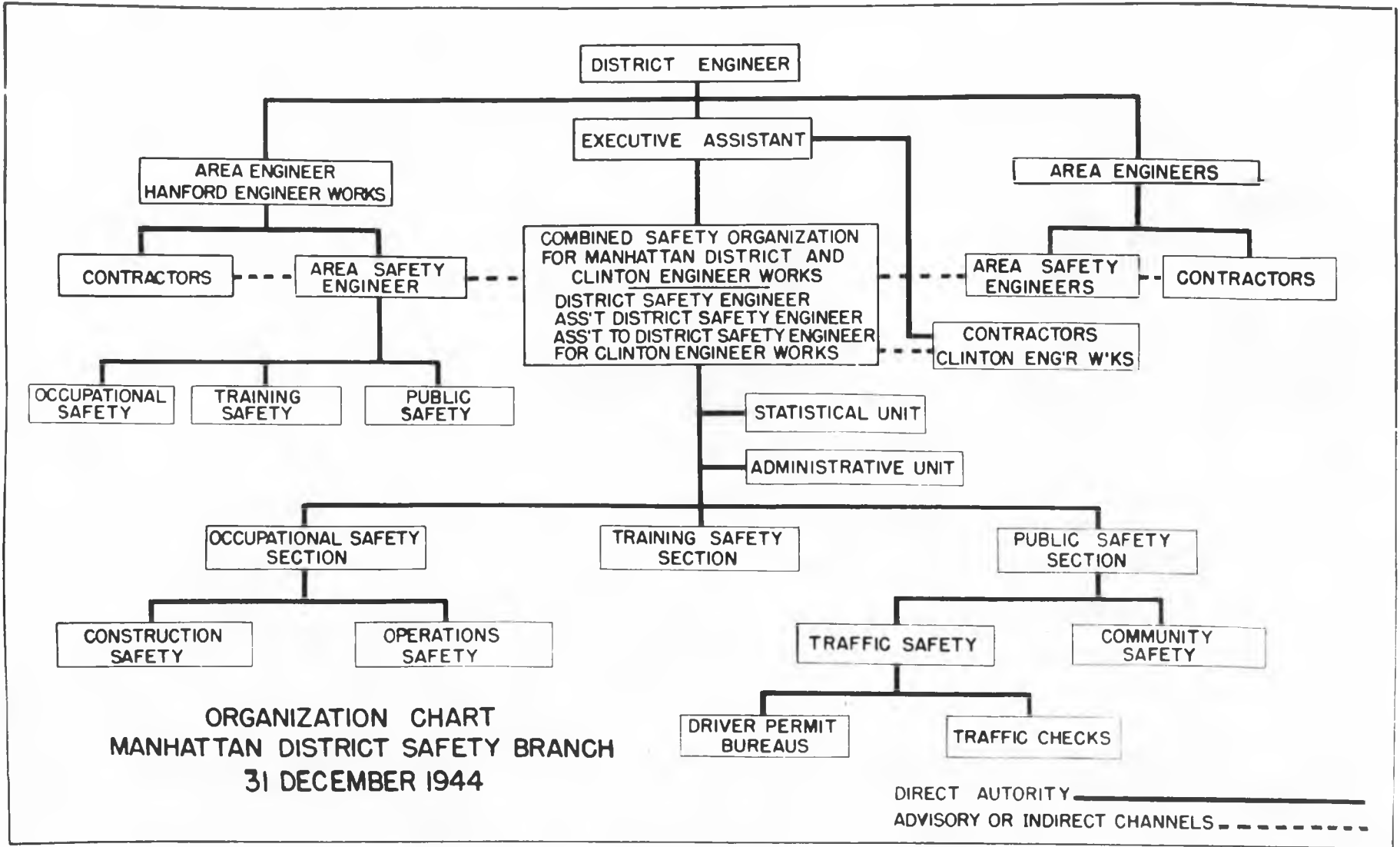

AP

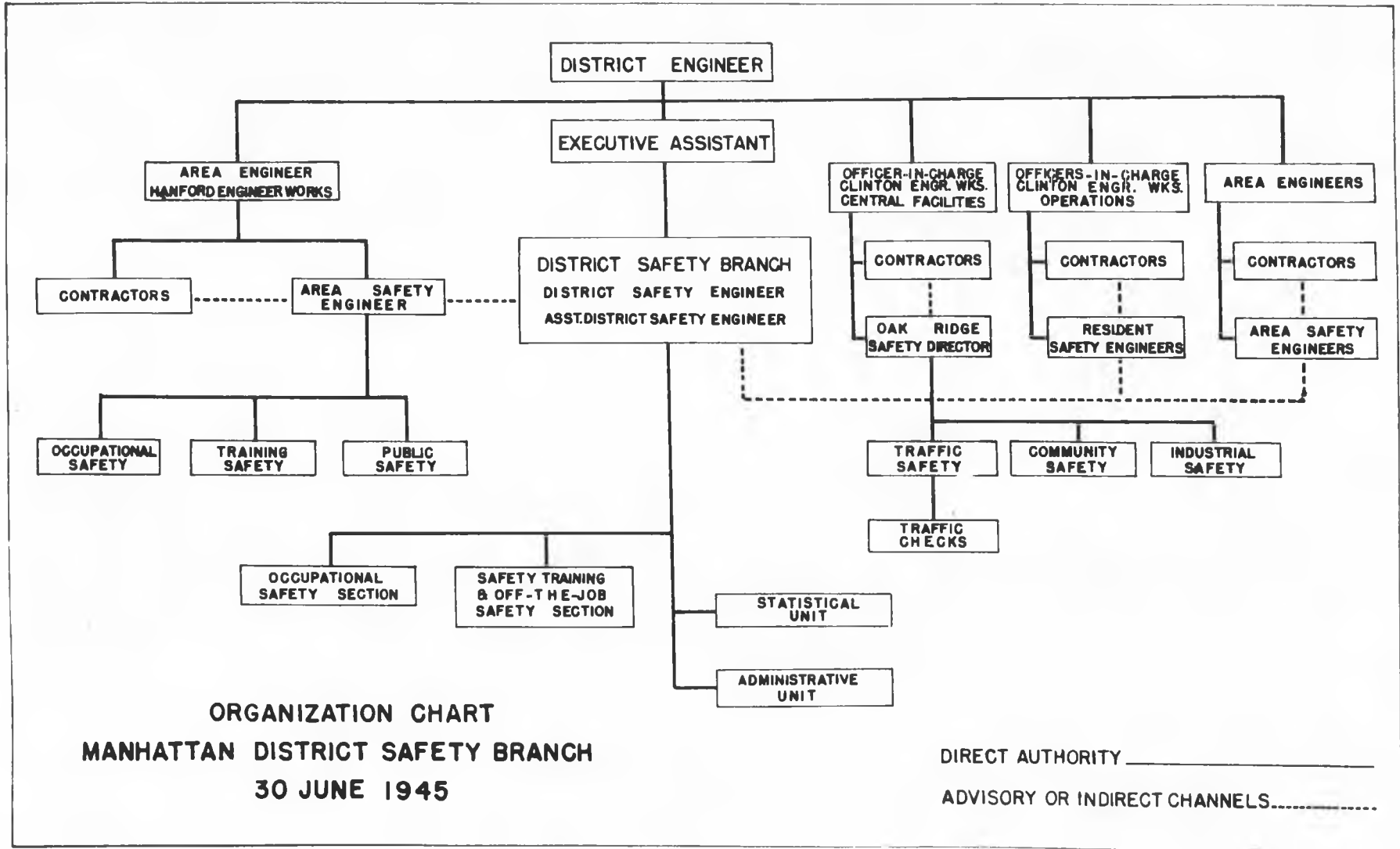

MANHATTAN DISTRICT SAFETY PROGRAM - CONTRACTORS EMPLOYING SAFETY PERSONNEL AND SAFETY COVERAGE BY DISTRICT PERSONNEL TO 30 JUNE 1945.

Location	Contractor	Prime Contractors Employing 1000 or More People (Including Sub-contractors) or Engaged in Hazardous Work					Manhattan District		
		Status of Work In Progress (P) Completed (C)	Type Work Construc- tion (C) Opera- tions (O)	Contractor Employment Peak (Incl. Sub-contr.)	Safety Engineer Full Time (F) Part Time (P) None (N)	Peak Number Safety Personnel	Total Peak Employment at CEW or Under Area Superv.	Safety Engineer Full Time (F) Part Time (P) None (N)	Peak Number Safety Personnel
Clinton Engr Works	American Industrial Transit	P	O	1264	F	6	80343	F	43
	E.I. duPont de Nemours & Co.	C	C	3090	F	6			
	H. K. Ferguson Co.	C	C	1917	F	3			
	Ford, Bacon & Davis, Inc.	C	C	3152	F	3			
	J.A. Jones Constr. Co. (a)	P	C	24915	F	25			
	Stone & Webster Engr. Co. (b)	P	C	27287	F	18			
	Carbide & Carbon Chem. Co.	P	O	11787	F	60			
	Clinton Laboratories	P	O	1673	F	3			
	Fercleve Corporation	P	O	1759	F	8			
	Ford, Bacon & Davis, Inc.	C	O	3005	F	15			
	Roane-Anderson Co.	P	O	10181	F	18			
	Tenn.-Eastman Corp.	P	O	22169	F	29			
<u>Areas</u>									
Alabama							725	(c)	(c)
Beverly							100	P	1
Boston (d)							824	P	1
California	University of California	P	O	1265	F	1	1275	P	1
Chicago	University of Chicago	P	O	1933	F	3	2640	F	2
Colorado	U.S. Vanadium Corp.	P	O	575	F	1	660	F	1
Columbia	Columbia University	P	O	1253	F	1	1430	F	1
Decatur	George A. Fuller Co.	C	C	1668	F	2	4724	F	2
	Houdaille-Hershey Corp.	P	O	4634	F	30			
Detroit	Chrysler Corp.	P		2655	F	1	2682	F	2

~~SECRET~~

MANHATTAN DISTRICT SAFETY PROGRAM - CONTRACTORS EMPLOYING SAFETY PERSONNEL AND SAFETY COVERAGE BY DISTRICT PERSONNEL TO 30 JUNE 1945.

Location	Prime Contractors Employing 1000 or More People (Including Sub-contractors) or Engaged in Hazardous Work						Manhattan District		
	Contractor	Status of Work In Progress (P) Completed (C)	Type Work Construc- tion (C) Opera- tions (O)	Contractor Employment Peak (Incl. Sub-contr.)	Safety Engineer Full Time (F) Part Time (P) None (N)	Peak Number Safety Personnel	Total Peak Employment at CEW or Under Area Superv.	Safety Engineer Full Time (F) Part Time (P) None (N)	Peak Number Safety Personnel
Hanford Engr. Works	E.I. duPont de Nemours & Co.	C	C	43811	F	87	45250	F	17
	" " " "	P	O	6127	F	15			
Iowa							185	N	0
Madison Square							650	F	1
Milwaukee							175	P	1
Morgantown							910	(c)	(c)
Murray Hill							135	N	0
New York	Kellex Corporation	P	O	1687	F	1	1870	F	1
Rochester							394	N	0
St. Louis							67	N	0
Tonawanda	Linde Air Products	P	C	409	F	5	2026	F	1
	" " " "	P	O	1515					
	Hooker Electrochemical	C	C	332	P	1			
	" " " "	P	C	183					
Trail	Consolidated Min'g & Smelt.	C	C	410	P	1	414	N	0
	" " " "	P	O	66					
Wabash River	E.I. duPont de Nemours & Co.	C	C	1550	P	2	1550	(c)	(c)
Wilmington	E.I. duPont de Nemours & Co.	C		1340	F	2	2100	F	1
	" " " "	P		1252	F	2			

~~SECRET~~

~~SECRET~~

Notes

a. Midwest Piping and Supply Co., a prime contractor employing more than 1000 persons, was on the same project as, and received safety coverage by, the J. A. Jones Construction Company.

Midwest employment is included.

b. O'Driscoll & Grove, Inc., John A. Johnson & Sons, Inc. and Clinton Home Builders, prime contractors employing over 1000 persons each, were under the Architect-Engineer Management of, and received safety coverage by, Stone and Webster. Employment for the three is included.

c. Safety activities during construction were supervised at Alabama by the Atlanta District, at Morgantown by the Pittsburg District and at Wabash River by the Chicago District. Operations safety was supervised by the Ordnance Department.

d. Principally design and engineering office.

~~SECRET~~

MONTHLY

GATE		A.M.									
		12	1	2	3	4	5	6	7	8	9
ELZA RIVER R'D.	IN	25	17	21	16	29	25	352	202	68	
	OUT	14	14	15	17	24	48	17	79	57	
ELZA TURNPIKE	IN	45	51	64	70	68	175	458	431	103	
	OUT	40	37	43	67	44	79	19	113	132	
SOLWAY	IN	14	10	3	4	4	102	1377	539	60	
	OUT	34	14	17	28	13	8	3	61	59	
EDGEMORE	IN	11	16	11	7	13	88	857	645	59	
	OUT	23	6	20	25	10	14	-	44	64	
OLIVER SPRINGS	IN	8	6	5	1	2	40	328	208	14	
	OUT	12	10	7	10	6	8	9	22	28	
POPLAR CREEK	IN	6	4	4	1	2	42	254	285	58	1
	OUT	14	6	3	17	3	8	23	54	81	1
GALLAHER	IN	-	-	-	-	-	12	453	378	53	
	OUT	-	-	-	-	-	2	9	42	74	
WHITE WING	IN	-	-	1	1	-	39	255	17	83	
	OUT	1	1	6	-	-	14	5	1	2	
MARLOWE	IN	-	-	-	-	-	6	21	14	12	
	OUT	-	-	-	-	-	3	2	5	5	

MONTHLY TRAFFIC VOLUME SURVEY

11 MAY 1944

HOURLY VOLUMES

												P. 1
8	9	10	11	12	1	2	3	4	5	6	7	
202	68	61	61	68	44	60	69	88	53	89	63	
79	37	59	45	48	27	46	47	87	124	477	110	
31	103	107	124	157	116	114	154	125	152	105	94	
13	132	129	120	115	120	87	101	156	193	558	318	1
339	60	34	42	40	39	53	110	81	77	34	28	
61	59	29	38	36	44	35	37	130	343	1146	301	1
45	59	35	41	33	35	32	75	61	82	19	39	
44	64	58	48	32	65	49	25	80	156	830	272	
08	14	9	20	18	26	21	27	14	20	15	21	
22	28	16	19	12	10	14	14	41	91	365	91	
85	58	132	96	129	62	22	11	30	29	20	17	
54	81	143	86	59	29	38	35	13	13	405	18	
178	53	35	40	58	51	69	92	88	137	19	21	
42	74	52	46	42	70	58	59	62	119	751	73	
17	83	7	4	4	6	12	8	5	5	-	1	
1	2	9	17	3	8	3	8	43	62	110	91	
14	12	-	-	-	-	-	-	4	3	3	5	
5	5	-	-	-	-	-	-	-	6	14	21	

IRVEY

~~CONFIDENTIAL~~

								TOTAL VOLUME	MAXIMUM HOURLY VOLUME		
P. M.									PEAK 5MINS	PEAK 15MINS	PEAK HOUR
5	6	7	8	9	10	11	12				
89	63	34	25	21	27	12	1588	528	488	385	
477	110	43	31	24	25	25	1503	780	716	505	
105	94	84	155	125	98	57	3232	816	752	592	
558	318	142	130	53	38	48	2882	960	840	590	
34	28	27	17	26	70	29	2811	2220	2040	1448	
1146	301	103	88	47	23	85	2722	1620	1812	1250	
19	39	26	23	42	80	32	2362	1320	1220	1030	
830	272	87	36	23	22	57	2046	1380	1380	884	
15	21	31	17	25	29	1	906	720	492	388	
365	91	47	34	13	18	9	906	756	552	382	
20	17	9	6	4	4	1	1228	552	528	438	
405	18	10	14	6	3	17	1098	780	680	405	
19	21	46	30	28	34	27	1671	1224	1076	708	
751	73	83	21	21	15	12	1611	1392	1256	751	
-	1	5	7	1	6	0	467	400	280	255	
110	91	21	9	19	3	7	443	280	140	130	
3	5	-	-	-	-	-	65	60	36	26	
14	21	-	-	-	-	-	56	60	36	21	

~~CONFIDENTIAL~~

OCCUPATIONAL INJURY EXPERIENCE

MANHATTAN DISTRICT

	<u>1943</u>	<u>1944</u>	<u>6 Mos. '45</u>	<u>Total</u>
TOTAL - ALL EMPLOYEES				
Employee-Hours Worked	103,997,329	311,249,331	132,637,136	547,883,796
Disabling Injuries	908	2,168	803	3,879
Fatalities	19	34	9	62
Time Charges (Days)	187,192	350,499	79,571	617,262
Frequency Rate	8.73	6.97	6.05	7.08
Fatality Rate	0.18	0.11	0.07	0.11
Severity Rate	1.80	1.13	0.60	1.13
EMPLOYERS OF CONSTRUCTION CONTRACTORS				
Employee-Hours Worked	88,287,680	206,901,622	50,653,451	345,842,753
Disabling Injuries	744	1,345	269	2,358
Fatalities	19	30	5	54
Time Charges (Days)	183,546	293,836	42,934	520,316
Frequency Rate	8.43	6.50	5.31	6.82
Fatality Rate	0.22	0.14	0.10	0.16
Severity Rate	2.08	1.42	0.85	1.50
EMPLOYERS OF OPERATIONS CONTRACTORS				
Employee-Hours Worked	12,599,964	95,221,977	77,828,154	185,650,095
Disabling Injuries	148	770	528	1,446
Fatalities	0	3	4	7
Time Charges (Days)	3,486	49,826	36,497	89,809
Frequency Rate	11.75	8.09	6.78	7.79
Fatality Rate	0.00	0.03	0.05	0.04
Severity Rate	0.28	0.52	0.47	0.48
GOVERNMENT EMPLOYEES				
Employee-Hours Worked	3,109,685	9,125,732	4,155,531	16,390,948
Disabling Injuries	16	53	6	75
Fatalities	0	1	0	1
Time Charges (Days)	160	6,837	140	7,137
Frequency Rate	5.15	5.81	1.44	4.58
Fatality Rate	0.00	0.11	0.00	0.06
Severity Rate	0.05	0.75	0.03	0.44

~~CONFIDENTIAL~~

~~CONFIDENTIAL~~

Appendix B-4

SAVINGS EFFECTED BY MANHATTAN DISTRICT OCCUPATIONAL SAFETY PROGRAM

<u>Employees In</u>	<u>Manhattan Dist. Employee-Hours</u>	<u>National Rates*</u>	<u>Expected Losses at Nat'l Rates</u>	<u>Actual Losses Manhattan Dist.</u>
<u>DEATHS</u>				
Construction 1943	88,287,680	.31	27	19
1944	206,901,622	.44	91	30
6 Mo. 1945	50,653,451	.44	22	5
Operations 1943	12,599,964	.08	1	0
1944	95,221,977	.08	8	3
6 Mo. 1945	77,828,154	.08	6	4
Government 1943	3,109,685	.06	0	0
1944	9,125,732	.06	1	1
6 Mo. 1945	4,155,531	.06	0	0
		Totals -	156	62
		Savings -	94	
<u>DISABLING INJURIES</u>				
Construction 1943	88,287,680	26.06	2,301	744
1944	206,901,622	27.70	5,731	1,345
6 Mo. 1945	50,653,451	27.70	1,403	269
Operations 1943	12,599,964	20.04	253	148
1944	95,221,977	18.40	1,752	770
6 Mo. 1945	77,828,154	18.40	1,432	528
Government 1943	3,109,685	14.77	46	16
1944	9,125,732	13.95	127	53
6 Mo. 1945	4,155,531	13.95	58	6
		Totals -	13,103	3,879
		Savings -	9,224	
<u>EMPLOYEE-DAYS LOST</u>				
Construction 1943	88,287,680	3.06	270,160	183,546
1944	206,901,622	3.68	761,398	293,836
6 Mo. 1945	50,653,451	3.68	186,405	42,934
Operations 1943	12,599,964	1.12	14,112	3,486
1944	95,221,977	1.07	101,888	49,826
6 Mo. 1945	77,828,154	1.07	83,276	36,497
Government 1943	3,109,685	.91	2,830	160
1944	9,125,732	.89	8,122	6,837
6 Mo. 1945	4,155,531	.89	3,698	140
		Totals -	1,431,889	617,262
		Savings -	814,627	

~~CONFIDENTIAL~~

~~CONFIDENTIAL~~

* U. S. Department of Labor Data. Severity rates on standard basis. 1944 Department of Labor rates used for 1945 also. Private construction compared with District construction. Private manufacturing compared with District operations. An average of private manufacturing and business services compared with Government, since many Government employees are stationed in operations areas, but many are in offices.

~~CONFIDENTIAL~~

~~CONFIDENTIAL~~

APPENDIX B 5
OCCUPATIONAL INJURY RATES OF MANHATTAN DISTRICT CONTRACTORS
CLINTON ENGINEER WORKS AND THE AREAS.

	CONSTRUCTION CONTRACTORS				OPERATIONS CONTRACTORS			
	2 years, 1943-44		6 Months, 1945		2 years, 1943-44		6 Months, 1945	
	Frequency	Severity	Frequency	Severity	Frequency	Severity	Frequency	Severity
DISTRICT AVERAGES	7.08	1.62	5.31	0.85	8.51	0.48	6.78	0.47
Clinton Engr. Wks.	7.33	1.79	5.83	0.26	7.26	0.65	7.55	0.66
Hanford Engr. Wks.	6.44	1.38	1.66	0.59	1.31	0.05	1.16	0.02
<u>OTHER AREAS</u>								
Alabama (1)	12.84	9.37	---	---	0.00	0.00	0.00	0.00
Beverly (2)	---	---	---	---	53.48	0.27	---	---
Boston	0.98	0.06	---	---	---	---	13.73	0.12
California	---	---	---	---	12.34	0.12	4.83	0.03
Chicago	11.56	0.20	0.00	0.00	14.74	0.14	10.27	0.12
Colorado (3)	52.05	1.42	---	---	31.95	2.19	4.41	0.04
Columbia	---	---	---	---	10.03	0.69	16.09	0.27
Decatur	14.06	2.26	0.00	0.00	4.92	0.32	2.80	0.07
Detroit	27.08	2.11	---	---	7.61	0.95	3.33	0.06
Iowa (4)	---	---	---	---	61.76	14.46	48.99	1.18
Madison Square	0.00	0.00	0.00	0.00	24.00	.37	16.91	0.17
Milwaukee	24.08	0.12	0.00	0.00	---	---	---	---
Morgantown	3.01	0.13	---	---	0.00	0.00	0.00	0.00
Murray Hill	---	---	---	---	11.31	0.60	0.00	0.00
New York	14.64	0.13	---	---	8.31	0.12	10.65	0.09
Rochester (5)	54.68	2.91	---	---	8.30	0.08	5.11	0.10
St. Louis (6)	0.00	0.00	---	---	73.39	0.18	---	---
Tonawanda	21.95	1.85	3.18	0.07	10.98	0.29	6.75	0.13
Trail (7)	58.26	0.96	---	---	6.22	0.02	11.16	0.06
Wabash River	2.24	2.48	---	---	0.00	0.00	0.00	0.00
Wilmington	3.68	0.29	---	---	1.86	0.07	1.36	0.00
Y-12 Projects	---	---	---	---	---	---	16.25	0.05

See Notes Attached.

~~CONFIDENTIAL~~

~~CONFIDENTIAL~~

NOTES, APPENDIX B 5.

General: Dashes indicate no work for the period. Figures shown for each Area include all installations and contractors directly supervised by that Area during the period. See Paragraph 1-3 for description of types of contracts covered by the safety program.

- (1) **Alabama:** The 1943 construction record showed 700,688 employee-hours with 9 injuries, one of which was fatal. Safety supervision rested with the Mobile District, U. S. Engineer Department.
- (2) **Beverly:** This project operated for only a short period as a cost-plus contract in the early stages of District safety work. There were 4 injuries in the first 2 months of operation with only 37,369 employee-hours, but only 1 injury in 5 subsequent months with 56,130 employee-hours and a frequency rate for the last 5 months of 17.8, well below the early rate.
- (3) **Colorado:** Injury rates were high in the early stages of the work, but a very effective program was built up. The construction record for 1944 was perfect. The 1944 operations frequency rate was only half the 1943 rate, but a permanent partial disability kept severity up.
- (4) **Iowa:** The high severity and frequency rates on the Iowa projects have resulted from the fact that the Iowa contractor had had no previous experience with industrial accident prevention techniques and, unlike most research laboratories, did not quickly effectuate the Government's accident prevention program, and second, the liberal leave policy of the contractor has put many minor injuries in the "lost time" category. In the first half of 1945, experience improved slightly -- the frequency rate was still extremely high, but severity is not high for the type of work.
- (5) **Rochester:** The construction program was very small. There were 5 injuries in two years, the employee-hour total amounting to only 91,437 -- the equivalent of 37 men for the two years. Rates were cut sharply in 1944, but the record shows the difficulty of organizing an effective program for a small exposure.
- (6) **St. Louis:** The St. Louis project operated for only a short period as a cost-plus contract. There were 2 injuries in 27,250 employee-hours during the period of Government safety supervision over operations.
- (7) **Trail:** Construction was practically complete in September 1943, early in the District's history, when the District organization for an effective nation-wide job was just being perfected. The inaccessibility of the project also contributed to a record below District standards.

~~CONFIDENTIAL~~

~~RESTRICTED~~

OCCUPATIONAL INJURY RATES

PRINCIPAL CONTRACTORS

CLINTON ENGINEER WORKS

1944 and 6 Months, 1945

	<u>1944</u>		<u>6 Months, 1945</u>	
	<u>Frequency Rate</u>	<u>Severity Rate</u>	<u>Frequency Rate</u>	<u>Severity Rate</u>
<u>CONSTRUCTION CONTRACTORS</u>				
CLINTON ENGINEER WORKS - TOTAL	6.24	1.65	6.26	0.90
E. I. du Pont de Nemours & Co.	3.81	0.23	---	---
H. K. Ferguson Company	2.12	0.01	6.72	0.43
Ford, Mason & Davis, Inc.	3.15	0.17	---	---
J. A. Jones Construction Co. (a)	5.45	1.39	5.99	1.09
Stone & Webster Eng. Co. (b)	7.70	2.07	8.35	0.27

<u>OPERATIONS CONTRACTORS</u>				
CLINTON ENGINEER WORKS - TOTAL	7.28	0.67	7.62	0.66
American Industrial Transit	---	---	9.61	0.12
Carbide & Carbon Chemicals Co.	8.09	0.21	8.40	0.13
Clinton Laboratories	2.66	0.35	1.67	0.04
Ferrelve Corporation	10.97	0.18	11.39	0.15
Ford, Mason & Davis, Inc.	8.59	4.57	8.88	0.94
Roane-Anderson Company	8.25	0.28	7.67	0.17
Tennessee-Eastman Corp.	7.08	0.49	7.29	1.19

Notes: Permanent records were not made on the 1943 injury experience of each, individual contractor. Sub-contractors experience is included in the rates shown above.

(a) Includes Kellex Corporation and Midwest Piping and Supply.

(b) Includes O'Briscoll & Grove, Inc., John A. Johnson & Son, Inc., and Clinton Home Builders.

~~RESTRICTED~~

MANHATTAN DISTRICT HISTORY

SAFETY PROGRAM

APPENDIX "C"

DOCUMENTS

<u>No.</u>	<u>Title</u>
1	Safety and Accident Prevention Program, Fiscal Year 1946, Manhattan District, including District Circular Letter (Safety 45-5) dated 29 June 1945.
2	Orders and Regulations, Corps of Engineers, U. S. Army, Chapter XI, Safety and Accident Prevention.
3	Safety Requirements for Excavation, Building, Construction, War Department, Corps of Engineers, with two amendments.
4	Report, Inspection of Decatur Area, 17-19 April 1945.
5	Safety Codes: <ul style="list-style-type: none">a. Index, Safe Practices and Health Practices Pamphlets, National Safety Council.b. Pamphlet No. 60, "Chemical Laboratories".c. Scheme for the Identification of Piping Systems, American Standards Association.
6	Safe Operating Practices, Tennessee-Eastman Corporation: <ul style="list-style-type: none">a. Cab-Controlled Cranes.b. Handling and Use of Oxygen and Acetylene.c. Electrical Hold-Offs and Lock-Outs.

APPENDIX "C", Continued.

<u>No.</u>	<u>Title</u>
7	Employees' Handbook of Safety Rules, Clinton Laboratories.
8	Safety Bulletins, Carbide and Carbon Chemicals Corporation: <ul style="list-style-type: none">a. Cylinder Storage and Handling.b. Operation of Service and Purge and Product Rooms.c. Operation of Degreasing and Pickling Area.
9	General Safety Rules, Fercleve Corporation.
10	Requirements for Moving Heavy Equipment, Roane-Anderson Company.
11	Monthly Report of Safety Activities. <ul style="list-style-type: none">a. Tennessee-Eastman Corporation, March 1945.b. Carbide and Carbon Chemicals Corporation, May 1945.c. Roane-Anderson Company, March 1945.
12	Traffic Regulations for Clinton Engineer Works, Oak Ridge, Tennessee.
13	Letters from the National Safety Council dated 12 November 1943, 30 November 1944, and 9 December 1944. Letters to the Council dated 26 November 1943 and 11 December 1944. Memo from Mr. James R. Maddy dated 12 January 1944.
14	Minutes of Combined Safety Meetings, 16 and 29 March 1945.
15	Brief Histories of Two Government Safety Engineers.
16	List of Resident Safety Engineers and Other Safety Engineers.

Safety & Accident Prevention

FISCAL YEAR

1946



UNITED STATES
ENGINEER OFFICE

MANHATTAN DISTRICT



~~RESTRICTED~~

**ARMY SERVICE FORCES
UNITED STATES ENGINEER OFFICE
MANHATTAN DISTRICT
OAK RIDGE, TENNESSEE**

IN REPLY REFER TO EIDMQ-5

29 June 1945

DISTRICT CIRCULAR LETTER (SAFETY 45-5)

Subject: Safety and Accident Prevention Program.

To: All Concerned.

1. Attached is a copy of the Manhattan District Safety and Accident Prevention Program for the fiscal year beginning 1 July 1945, which sets forth the basic safety policies of the District and outlines the status, organization and function of the District Safety and Accident Prevention Branch.

2. The program has been developed and conforms with the safety concepts of the Engineer Department, expanded to include community, traffic and off-the-job safety, responsibilities uncommon to other Districts.

3. It is desired that Area Engineers and Officers in Charge establish sound, practical, definite, and comprehensive, safety programs and objectives for all activities under their jurisdiction and, through constant and positive supervision, assure continued progress in fulfilling this responsibility.

Incl.:
1946 Program.

K. D. Nichols
K. D. NICHOLS,
Colonel, Corps of Engineers,
District Engineer.

Distribution:
AE & H

The following District Safety Circular Letters are in effect:

43-1
43-2
44-2

44-4
44-5
44-10

44-11
44-12
45-3

~~RESTRICTED~~



MANHATTAN DISTRICT
SAFETY AND ACCIDENT PREVENTION PROGRAM

FISCAL YEAR

1946

Submitted James R. Maddy
JAMES R. MADDY,
District Safety Engineer.

Recommended Floyd P. Trent
FLOYD P. TRENT,
Major, Corps of Engineers,
Assistant.

Approved K. D. Nichols
K. D. NICHOLS,
Colonel, Corps of Engineers,
District Engineer.



TABLE OF CONTENTS

<u>ARTICLE</u>	<u>PAGE</u>
I. Purpose and Objective	1
II. Scope	1
III. The Problem	2
IV. Organization	2
V. Joint Responsibilities	4
VI. Occupational Safety Program	5
VII. Safety in Government Operated Communities	8
VIII. General Public Safety Activities at all Projects	10
IX. Research and Development	11
X. Statistical	11
XI. Administrative	11
XII. Manhattan District Safety and Accident Prevention Organization	13

MANHATTAN DISTRICT

SAFETY AND ACCIDENT PREVENTION PROGRAM

FISCAL YEAR - 1946

I. Purpose and Objective.

1. It is essential to the accomplishment of the mission of the Manhattan District that all necessary steps be taken to minimize the loss of productive labor and the damage of equipment and materials due to accidents.

2. The purpose of establishing an accident prevention program for the Manhattan District is to definitely set forth the basic policies and procedures to be followed by all Areas of the District for the further improvement of the safety organization in efficiency, economy, and the coordination of functions.

3. The program shall be an application of sound engineering techniques and practices and shall conform with policies established by the Office, Chief of Engineers and to accepted safety training doctrines.

4. The objective of the program is the reduction of the number and severity of personal injuries and property damage due to accidents.

II. Scope.

The Manhattan District safety program will include:

- a. Occupational safety of Government employees and military personnel.
- b. Occupational safety of employees of:
 - (1) All construction contractors.
 - (2) All contractors receiving reimbursement for payroll costs.
 - (3) Service and supply contractors and concessionaires while performing work at any site under the jurisdiction of the Manhattan District.
- c. Public safety in the communities operated by the District.
- d. Off-the-job safety promotion for Government employees, military personnel, and the employees of contractors described above.

- b. Inspection of all Areas and facilities to determine that minimum safety requirements are being complied with.
- c. Frequent, thorough safety engineering service for Areas and facilities too small to warrant employment of a full-time resident safety engineer.

3. The Area Engineer or Officer in Charge of work is responsible for the conduct of an effective, balanced safety program covering all work under his jurisdiction.

4. The safety organization in each Area or operation will be under the direct supervision of the respective Area Engineer, Officer in Charge, or his Executive Officer.

5. When established policy requires a full-time safety engineer on an Area Engineer's and/or contractors staff, the safety engineer will not be given other duties.

6. An Area Engineer may place additional, general responsibility for fire prevention and protection on his safety engineer over and above the responsibility to consider all elements of personal safety, which is assigned to safety personnel in all echelons of the District.

7. The District Safety Branch will, upon request of the Area Engineer or Officer in Charge, the Medical Branch, or the Security Branch, perform such safety engineering work as may be required for production security.

8. The responsibility for enforcement of safety regulations throughout the entire District rests on the personnel responsible for the work supervision. Under no circumstances shall the responsibility for enforcement of safety requirements be taken from the normal supervisory lines and placed with the safety engineer.

9. Safety engineers will serve in a staff capacity, will advise the respective contractors or operators, and will work with all departments and supervisors in the coordination of safety work and the fulfillment of contractual obligations.

10. Contractors are responsible for the occupational safety of military personnel under their work supervision. The Government program will include Detachment Areas and military personnel not assigned to or working in close association with contractors. All military personnel are covered by the public safety program.

VI. Occupational Safety Program.

1. The Corps of Engineers "Safety Requirements for Excavation, Building, Construction," as amended, shall constitute the minimum safety requirements for all work under the jurisdiction of the Manhattan District.

2. For specific items in construction, maintenance or operations activities, where the "Safety Requirements" as supplemented by the District Safety Branch, do not provide coverage or pertain, supplemental safety requirements will be developed at the site in accordance with the best of recognized and accepted procedures. Such supplemental safety requirements will be reviewed and approved by the Area Engineer or Officer in Charge, and forwarded to the District Office.

3. Each Area Engineer or Officer in Charge supervising Government or contractor employees with a combined monthly exposure of 80,000 or more employee-hours shall have a full-time, qualified safety engineer on his staff.

4. Area Engineers or Officers in Charge will see that a Board of Investigation is appointed to determine the causes, fix responsibility, and recommend preventative measures after each fatal accident.

5. A program to increase interest in accident prevention will be maintained for Government employees through monthly bulletins, encouragement of individual participation, and the elimination of physical hazards in offices. All buildings assigned to or primarily occupied by Government employees will be surveyed for hazards and compliance with safety requirements.

6. The work of the District and Area occupational safety engineers is unusual in that the direct safety engineering work and field correction are responsibilities of the contractors. Government safety engineers serve as liaison engineers to contractors' safety departments and insure through the Area Engineer or Officer in Charge, correction of violations of safety requirements and deficiencies of organization, and encourage progressive engineering techniques which will prevent accidents. The occupational safety program, therefore, outlines the activities to be executed through initiative of the contractors' safety departments as well as from the guidance of the District and Area Safety Staffs and support of the Area Engineer or Officer in Charge.

7. The development of an adequate safety and accident prevention program is a contractual obligation and the safety program of each contractor will be expected to include:

- l. Complete and regular inspections, tests, and maintenance of all equipment, machines and tools that would create a hazard if not properly maintained -- high pressure lines, pressure vessels, acid lines, safety valves, pressure gauges, automotive equipment, hoists, cranes, hand tools, etc.
- m. Inspection systems to identify and eliminate unsafe physical conditions and to discover and correct unsafe acts which might lead to accidents.
- n. Protection of health from material and processes peculiar to the activities of the Manhattan District through enforcement of practices and procedures developed by contractor and/or Government medical and safety departments.
- o. Services comparable to those furnished normally by industrial hygiene units to determine the existence of problems and hazards coming within the scope of the industrial hygienist, measures for the elimination of hazards through either engineering revision, supplying necessary protective equipment, specifying selection and placement of workers or similar methods.
- p. An educational program to begin the day an employee is hired, including a good set of safety rules in pocket manual form, as well as timely information and procedures on specific operations; procedures and information furnished to supervisors, and through supervisors to all workers.
- q. Thorough investigation of all occupational accidents, not only to prevent their recurrence at the same site, but also to develop experience, policy, and training procedures to prevent them from occurring elsewhere.
- r. Accurate and complete injury reports and summaries as required by District Circulars.
- s. Preparation of a program of safety training, to satisfy the following basic requirements:
 - (1) Safety instruction as a part of the orientation program.
 - (2) Safety integrated in employee job training courses.
 - (3) Safety instruction to the employee on the job through the media of safety meetings and job instructions by the foremen. The safety departments

- g. Street lighting installations or improvements where lighting is at present inadequate and hazardous.
- h. Re-design of street intersections, roadways, and parking facilities at locations where the layout is hazardous or inadequate for handling traffic.
- i. Recommendations for parking and other traffic facilities and control measures in the restricted areas.
- j. Investigation of complaints and referred matters concerning traffic conditions and driver practices and prepare recommendations for correction.
- k. Standard specifications for determining the need for manual traffic control by police for guidance of the guard force.

2. Other Public Safety and Home Safety.

- a. Reporting of off-the-job accident cases from hospitals and use of these data for guidance and planning of home and public (non-traffic) safety activities.
- b. Improvement of the accident reporting from the schools and compilation and interpretation of these data for use in instruction and in guiding the school safety program.
- c. Inspections of public buildings and schools to determine unsafe conditions or practices.
- d. Inspection of playgrounds and other recreational facilities to determine hazardous conditions or practices and plan improvements.
- e. Improvement in the use and training of school safety patrols.
- f. Inauguration of safety activities in departments and agencies having public accident problems, with appropriate set-ups for handling such activities.

3. Public Education.

- a. Proper publicity for traffic, home and other public safety activities through newspapers published by or serving communities of the Manhattan District.

District, and develop measures for improvement with respect to operating personnel, equipment and procedures.

3. Furnish available information concerning public and home hazards to stimulate interest in public safety activities.

IX. Research and Development.

1. The work of the Manhattan District is such that new, often technically complex, problems of personal protection, susceptibility, tolerances, and toxicity, as well as problems arising out of design of new types of equipment, continually arise. The Medical Branch and the Safety Branch will continue to study new and unusual problems and experiment with controls to cope with them. The Safety Branch will keep informed of developments in related research fields.

2. The Safety Branch will study its accident records to accurately define accident problems and indicate ways of developing new and better methods of controlling hazards, particularly the special hazards of Manhattan District work.

3. The Safety Branch will conduct and attend such safety conferences as are essential to the functions of the Branch.

X. Statistical.

The District Safety Branch will:

1. Collect, review, and prepare statistical summaries of all Manhattan District personal injury reports.

2. Complete audit semi-annually of all accident records to establish completeness and correctness.

3. Prepare special analyses from accident reports and records either initiated or requested.

4. Install a McBee Keysort System for more efficient analysis of operations injury reports.

5. Prepare monthly releases of accident data to all Areas of the Manhattan District.

XI. Administrative.

The District Safety Branch will:

1. Consolidate District requirements for safety material, forms, and publications and distribute same to the Areas and other offices of the Manhattan District.

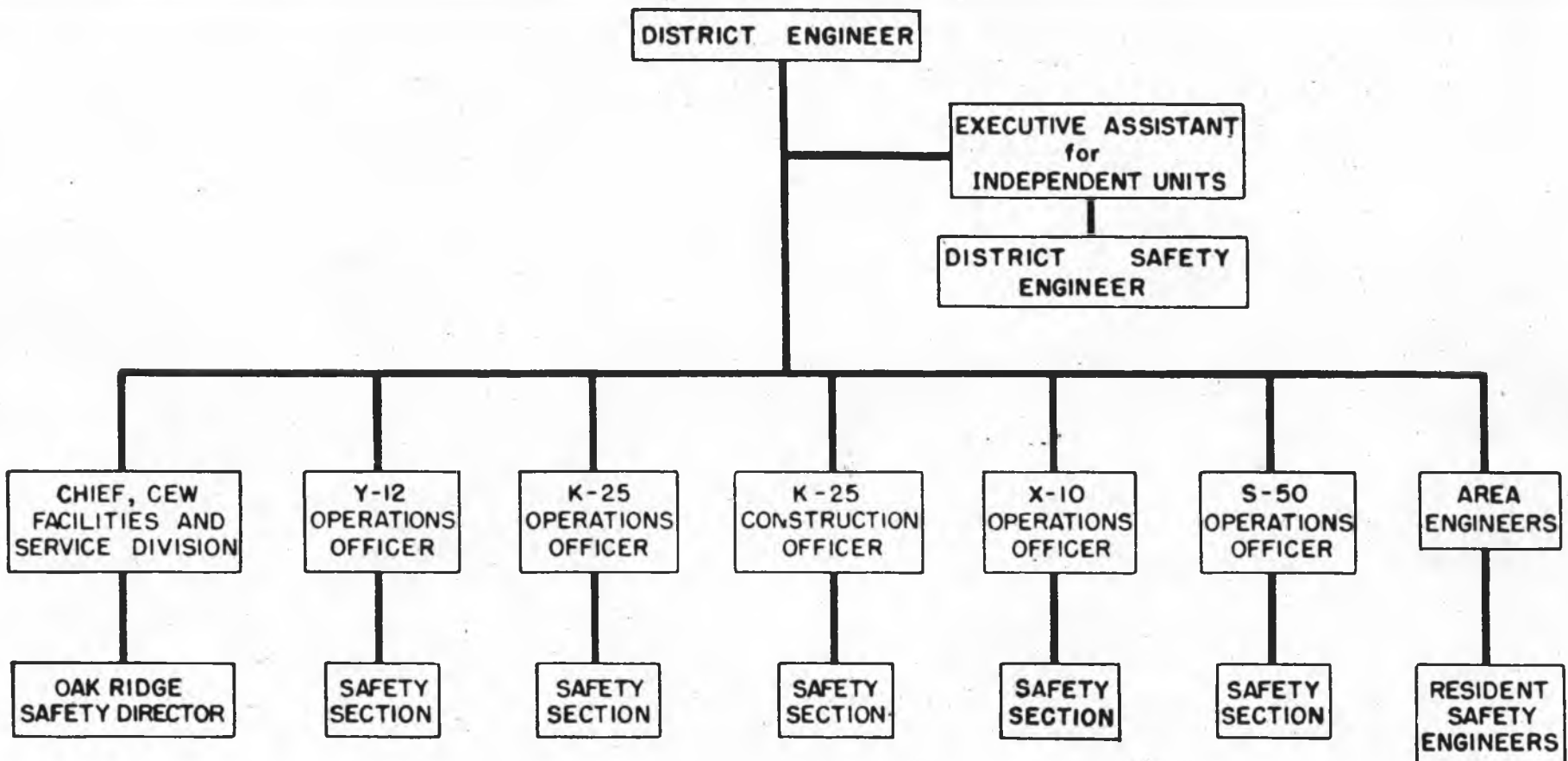

MANHATTAN DISTRICT SAFETY AND ACCIDENT PREVENTION ORGANIZATION

16 JUNE 1945

**ORDERS AND REGULATIONS
CORPS OF ENGINEERS
U. S. ARMY**

CHAPTER XI

**SAFETY AND
ACCIDENT PREVENTION**



2 SEPTEMBER 1944

**This pamphlet supersedes Chapter XIV,
Orders and Regulations, 15 January 1943,
and includes all revisions, amendments,
and changes to 2 September 1944.**

CHAPTER XI

SAFETY AND ACCIDENT PREVENTION

SECTION 1 - POLICY

1101.01 STATEMENT OF POLICY.— a. It is essential to efficient conduct of all work under the jurisdiction of the Corps of Engineers, and the protection of all employees, that every practical means be utilized to eliminate or minimize all accident, fire and health hazards in its operations and that personal protective devices, equipment and apparel be provided, as the type of work exposure requires.

b. All work performed by contract will be in compliance with the established Safety Requirements of the Corps of Engineers.

c. A comprehensive and continuous accident prevention program will be maintained throughout the Corps of Engineers for the purpose of preventing deaths, injuries, occupational sickness and disease to Government employees and the destruction of and damage to materials, equipment, plant and other property.

SECTION 2 - ORGANIZATION

1102.01 OFFICE OF THE CHIEF OF ENGINEERS.— There is established in the Office of the Chief of Engineers the Safety and Accident Prevention Branch hereinafter referred to as the Safety Branch. The scope of the Branch will include;

(1) The personal safety of all Government employees in all operations under the jurisdiction of the Chief of Engineers.

(2) Inclusion of safety engineering techniques and practices in design, plans and construction of buildings, equipment, plant and other facilities in order to provide maximum safety for occupants and operators.

(3) First aid and other medical treatment of accidental injuries and occupational diseases.

(4) Health and sanitation, physical examinations for safety purposes, inoculation, vaccination and immunisation; medical and hospital service and supplies; drinking water, toilet and sewage facilities.

(5) Standards and requirements for fire prevention and protection relating to civil works operations, plants, buildings, equipment and other facilities.

(6) Examining, testing and training of motor vehicle operators, training of supervisory personnel and other safety training activities.

- (7) Compliance with Safety Requirements.
- (8) Liaison with the United States Employees' Compensation Commission on matters relating to reporting procedures.
- (9) Liaison with the Office of the Surgeon General on matters relating to occupational injuries, hygiene and disease.

1102.02 ADMINISTRATION OF THE SAFETY BRANCH.— a. The Chief of the Safety Branch will be responsible for:

- (1) Development and promulgation of policies and doctrine within the scope defined.
- (2) Promulgation of Safety requirements and standards for all Contract and Hired Labor work.
- (3) Preparation of all Safety forms, maintenance of records and related activities.
- (4) Detailed analysis of all reports for the purpose of: Developing patterns and trends, preparing forecasts for advance planning, developing and evaluating economic aspects, correlating and coordinating activities and related data.
- (5) Planning, organizing, promulgating and initiating activities throughout the Corps of Engineers serving as consulting specialist for the Chief of Engineers on safety engineering, accident prevention and occupational health and sanitation matters and as his representative at conferences and technical meetings concerning such activities.
- (6) Field visits and studies in Divisions and Districts for the purpose of effectuating the accident prevention program, providing assistance in administrative and technical problems, safety training, enforcement of safety requirements, and other related activities.
- (7) Review and evaluation of effectiveness of field organization and program and the development and initiation of the corrective measures indicated.

b. The Assistant Chiefs of the Safety Branch will be responsible for:

- (1) Sharing the direction and control of the administrative and technical functions of the Branch.
- (2) Assuming the duties of the Chief of the Branch in his absence.
- (3) Providing for final executive action, expert advice and recommendations on safety engineering and accident prevention problems and policies.
- (4) Performing related work as assigned.

1102.03 FIELD ORGANIZATION AND OPERATIONS.— a. Field operations comprise the offices of the Division and District

Engineers and independent establishments and all work under their jurisdiction.

b. Each Division Engineer will maintain a Safety and Accident Prevention Branch or Section charged with the responsibility for the direction and supervision of all accident prevention activities in the Division. A full time qualified civilian Safety Engineer will be designated Chief of the Branch or Section.

c. Each District Engineer will maintain a Safety and Accident Prevention Branch or Section charged with the responsibility for the direction and supervision of all accident prevention activities in the District. A full time, qualified civilian Safety Engineer will be designated Chief of the Branch or Section.

d. Each independent establishment shall maintain such Safety and Accident Prevention organization as prescribed by the Chief of Engineers.

e. The organization and scope of operations of the Division and District Safety and Accident Prevention Branches, or Sections shall conform, as far as possible, to that of the Safety and Accident Prevention Branch, Office of the Chief of Engineers.

f. Each project or area, either contract or hired labor, with an optimum monthly exposure of 80,000 man-hours or more shall be under the safety engineering supervision of a full time, qualified civilian Safety Engineer.

g. A project or area, either contract or hired labor, with unusual hazards or one with work spread over large areas will also require full time safety engineering supervision regardless of the fact that the monthly total man-hours may be less than the foregoing standard.

h. Projects or areas not in either of the above categories will be grouped for purposes of most effective safety engineering supervision on the basis of one full time, qualified civilian Safety Engineer per group totaling 80,000 man-hours monthly.

SECTION 3 - ACCIDENT REPORTS

1103.01 GENERAL. -- Set forth herein are the incidents for which individual reports relating to civil work will be submitted through channels to the Office of the Chief of Engineers.

(1) Death, permanent total, permanent partial, temporary total or partial disability and sickness or disease occurring from the occupation of an employee, of either contractor or the Corps of Engineers, which prevents his or her return to work on the next calendar day or shift or which results in loss of time only on the day of injury.

(2) Motor vehicle accidents involving a Government vehicle resulting in death or injury to person, or property damage only.

(3) Damage or destruction by fire in the amount

of \$100 or more, involving civil works construction, equipment and plant.

(4) All accidents resulting in property damage only of \$25 or more, not covered in paragraphs 1 to 3 above (including marine, tornado, hurricane, flood and similar incidents.)

b. The reporting of lost time injuries on military construction and at installations transferred to the Chief of Engineers in a standby status or for disposal, will be in accordance with current instructions from Headquarters, Army Service Forces.

NOTE: Instructions and forms to be used will be prescribed by Circular Letter.

1103.02 MONTHLY SUMMARY REPORTS.— Reports required in paragraph 1103.01 will be summarized at the expiration of each calendar month and submitted to the Office of the Chief of Engineers.

NOTE: Instructions and forms to be used will be prescribed by Circular Letter.

1103.03 SPECIAL REPORTS.— Immediate notification will be made by teletype or telegraph to the Chief of Engineers, Attention: Safety and Accident Prevention Branch, of all accidents resulting in death or critical injury or property damage only of \$500 or more. The report will include date and time, name of employee or location of fire or property damage. These reports will be promptly followed with a detailed investigation.

SECTION 4 - SAFETY REQUIREMENTS

1104.01 GENERAL.— All work performed under jurisdiction of the Corps of Engineers will be in compliance with the "Safety Requirements for Excavation, Building, Construction", approved by the Chief of Engineers, 16 December 1941, and amendments thereto as approved and issued pending reprint of "Safety Requirements".

b. Division and District Engineers may establish rules and regulations applicable to occupational hazards and unsafe practices not prescribed in the "Safety Requirements for Excavation, Building, Construction". A copy of such rules and regulations shall be promptly transmitted to the Office of the Chief of Engineers.

1104.02 ENFORCEMENT OF CONTRACT PROVISIONS.—a. Construction Contract Work. All construction contract work under the jurisdiction of the Corps of Engineers will be performed in compliance with the "Safety Requirements for Excavation, Building Construction", revised 15 March 1943

and as amended. (See PR 362).

b. Supply Contracts. Contracting Officers will require strict compliance with the provisions of Article 4(b) WD Contract Form No. 1.

1104.03 HIRED LABOR WORK.— All work performed by the employees of the Corps of Engineers will be in compliance with the "Safety Requirements for Excavation, Building, Construction", and other directives promulgated as needs are determined.

SECTION 5 - PROTECTIVE EQUIPMENT

1105.01 PERSONAL PROTECTIVE AND OTHER EQUIPMENT AND APPAREL. — Procurement will be in accordance with the pertinent provisions of Chapter VII Orders and Regulations. The provision of paragraph 8302.04, "Safety Requirements for Excavation, Building, Construction" will govern in the use of protective equipment and apparel.

SECTION 6 - TRAINING AND EDUCATION

1106.01 SAFETY TRAINING.— a. This is a responsibility of the Safety Branch by delegation from Civilian Personnel Branch. Close collaboration will be maintained with the Training Section, Civilian Personnel Branch, and monthly reports of progress will be submitted to the Training Section.

b. VISUAL AIDS IN EDUCATION AND TRAINING.— All requests for posters, pamphlets, safe practices and other material of the National Safety Council, and other technical publications and materials essential to education and training will be transmitted through official channels to the Chief of Engineers, Attention: Safety and Accident Prevention Branch for central purchase of all such material in order to secure quantity prices and to facilitate purchase and distribution.

SECTION 7 - HEALTH AND SANITATION

1107.01 MEDICAL EXAMINATIONS.— a. Physical Examinations of employees are authorized for the following purposes:

(1) In emergency to determine whether or not there exists a communicable disease, mental derangement or when malingering is suspected.

(2) To determine whether or not physical defects exist that are incompatible with a particular work or assignment.

(3) To determine fitness as food handlers in order to prevent food contamination.

b. PHYSICAL EXAMINATION IN EMERGENCY CASES.— In any case in which the physical examination of an employee in the service is required at an early date to ascertain whether the employee has a communicable disease, mental derangement, or to ascertain his fitness for duty, or when

6

malingering is suspected, and it is desired that such examination be given by an officer of the Public Health Service, request for authority to apply to the nearest representative of the Public Health Service, request for such examination should be presented to the Chief of Engineers for transmission to the Secretary of War, who will take action in accordance with general authority granted by Departmental Circular No. 79 of the Civil Service Commission dated 18 July 1931. In other cases, statement to the effect, that early action is not necessary should be made in order that request for authority to apply to the representative of the Public Health Service for the necessary examination may be forwarded to the Civil Service Commission.

Physicians of the Public Health Service will make physical examinations of employees of the Engineer Department of all classes, including seasonal, unclassified, and temporary, upon proper request from the responsible officer of the Engineer Department, provided such examinations do not interfere with the routine care and treatment of legal beneficiaries of the Public Health Service. Full advantage should be taken of this offer in all cases where it is practical, so that the physically unfit, whether new or old employees, may be placed in work where the chances of injury are at a minimum. In the event that physicians of the Public Health Service are not available for this emergency service, Division and District Engineers may request authority from the Chief of Engineers to engage private physicians for the purpose.

c. PHYSICAL EXAMINATION OF FOOD HANDLERS.-- (1) All prospective food handlers as defined below will be required to undergo a prescribed examination before being employed and semi-annually thereafter, except that a special examination may be required if signs or symptoms of any communicable disease are noted.

(2) The term "food handlers" will be construed to include all persons who are regularly and continuously assigned to such duties as will require them to prepare and serve food or drink or to handle dishes, tableware, or kitchen utensils. Included in this category will be: cooks, assistant cooks, cooks' helpers, bakers, butchers, meat cutters, waiters, dining room and kitchen helpers handling and washing dishes and kitchen utensils, mess foremen, and any other person who comes in constant and intimate contact with food in other than unbroken packages which are protected against contamination.

(3) No person in the transmissible stage of a communicable disease or who is a known carrier of the causative organisms of such a disease or otherwise unsuitable for the work of a food handler, either at the time of the initial examination or subsequently, will be employed as such.

(4) Wherever practicable, the examination of food handlers, both before employment and thereafter, will be

made by physicians of the Public Health Service, the Veterans' Administration, or by a member of the Army Medical Corps. Where Government medical facilities are not available, District Engineers may request authority from the Chief of Engineers to engage the services of a private physician or clinic for the purpose at Government expense.

(5) The standards to be applied, the instructions to be followed and the forms to be used in connection with the above examinations will be prescribed by Circular Letter.

1107.02 INOCULATIONS, VACCINATION AND IMMUNIZATION.--a. Although not mandatory, preference in employment will be granted to personnel who have been immunized or signified their willingness to be immunized against certain diseases.

(1) Inoculation against typhoid should be arranged through the surgeon of the nearest army camp or post, or, if this is not convenient or possible, through the public health officer at the nearest station of the United States Public Health Service. When these facilities are not available, the service may be secured through the assignment of a regularly employed medical officer of the Engineer Department or the engagement of a physician on a fee basis.

(2) Vaccination against small-pox and inoculation against Rocky Mountain spotted fever, poison oak and poison ivy will not be performed without prior authority of the Chief of Engineers. Request for authority should state whether the service will be rendered by regular medical officer of the Government or by a physician to be engaged on a fee basis. If the latter, the request should state the fee proposed.

1107.03 MEDICAL AND HOSPITAL SERVICE.-- a. Medical, surgical and hospital services will or may be provided employees as prescribed herewith:

(1) Employees injured in line of duty will be treated and hospitalized by the United States Employees' Compensation Commission.

(2) The officers in charge of river and harbor, flood control or other civil works of the Engineer Department are further hereby authorized, in case of sickness incurred in the line of duty of any employee when serving in the field, to take such steps as follows for his care, including medical and surgical treatment to such extent as the case may require:

(a) In the case of slight and passing ailments, to supply the employee with such simple and ordinary remedies as can be used safely without the employment of a physician, and for that purpose to purchase and keep on hand a sufficient supply of suitable medicines, remedies, and appliances.

(b) In cases of the appearance of any contagious or infectious disease among his employees, to take

all such prompt and effective steps, and to use all such precautions as shall be necessary for the care of those attacked by the disease and to prevent its communication to others. The provisions of the paragraph shall apply to both field and office employees.

SECTION 8

PROCEDURE FOR COMPENSATION FOR INJURIES

1108.01 LAWS AND REGULATIONS.— The provisions of law governing compensation of injured employees, employees' compensation fund and the United States Compensation Commission are contained in the Act of 7 September 1916, as amended by the Acts of 5 June 1924, 6 June 1926, 12 February 1927, 13 May 1936, and 6 April 1938. The United States Employees' Compensation Commission has also published regulations in accordance with the Act.

1108.02 REPORTING PROCEDURE.— All reports concerning employee compensation, except those relating to the rights and benefits of employees, will be processed by the Safety and Accident Prevention Branch of the Office of the Chief of Engineers for that office and by the Safety and Accident Prevention Branches or Sections of the Division and District offices and Independent Establishments for their respective jurisdictions. Copies of all reports will be forwarded to the appropriate Civilian Personnel Officer. Direct contact with the United States Employees' Compensation Commission will be maintained by the above mentioned offices.

ORDERS AND REGULATIONS
CHAPTER XI
SAFETY AND ACCIDENT PREVENTION

TABLE OF CONTENTS

<u>Section</u>		<u>Paragraph</u>
1	Policy	1101.01
2	Organization	
	Office of the Chief of Engineers.....	1102.01
	Administration of Safety Branch.....	1102.02
	Field Organization and Operations.....	1102.03
3	Accident Reports	
	General.....	1103.01
	Monthly Summary Reports.....	1103.02
	Special Reports.....	1103.03
4	Safety Requirements	
	General.....	1104.01
	Enforcement of Contract Provisions.....	1104.02
	Hired Labor Work.....	1104.03
5	Protective Equipment	
	Personal Protective and other Equipment and Apparel.....	1105.01
6	Training and Education	
	Safety Training.....	1106.01
7	Health and Sanitation.	
	Medical Examinations.....	1107.01
	Inoculations, Vaccination and Immunization.....	1107.02
	Medical and Hospital Service.....	1107.03
8	Procedure for Compensation for Injuries	
	Laws and Regulations.....	1108.01
	Reporting Procedure.....	1108.02

WAR DEPARTMENT • CORPS OF ENGINEERS
UNITED STATES ARMY

Safety Requirements

for

- EXCAVATION
- BUILDING
- CONSTRUCTION



WAR DEPARTMENT • CORPS OF ENGINEERS
UNITED STATES ARMY

Approved by the Chief of Engineers
December 16, 1941
Revised March 15, 1943

Safety Requirements for

- EXCAVATION
- BUILDING
- CONSTRUCTION

OFFICE OF THE CHIEF OF ENGINEERS
CONSTRUCTION DIVISION
SAFETY AND ACCIDENT PREVENTION BRANCH



United States Government Printing Office
Washington : 1943

TABLE OF CONTENTS

	Page	
Definitions	8301.00	1
GENERAL REQUIREMENTS		
Drinking Water	8302.01	5
Toilet Facilities	8302.02	5
First-Aid Stations and Infirmaries	8302.03	6
Protective Equipment and Practices	8302.04	14
Lighting	8302.05	14
Gas and Smoke	8302.06	14
Salamanders	8302.07	14
Accident Reporting	8302.08	15
Employment of Safety Engineer	8302.09	15
Transporting Project Personnel	8302.10	15
Storing Materials and Disposal of Waste	8302.11	16
SPECIFIC REQUIREMENTS		
Steam Boilers:		
Inspection	8303.01	19
Excavation:		
Excavations	8304.07	21
Trench Excavation	8304.08	21
Ropes, Cables, Chains:		
Inspection and Use	8304.09	23
Ramps, Runways, Platforms, and Scaffolds:		
General	8305.01	28
Nails	8305.02	29
Scaffold Loads	8305.03	29
Pole Scaffolds	8305.04	30
Outrigger Scaffolds	8305.05	33
Horse or Frame Scaffolds	8305.06	34
Ladder Jack Scaffolds	8305.07	36
Carpenters' Portable Bracket Scaffolds	8305.08	36

Ramps, Runways, Platforms, and Scaffolds—Continued.

Window Jack Scaffold.....	8305. 09
Foot Scaffolds.....	8305. 10
Guard Rails, Toe Boards, Screens.....	8305. 11
Roofing Devices.....	8305. 12
Temporary and Permanent Stairways.....	8305. 13
Temporary Floors.....	8305. 14
Painters' Swinging Scaffolds.....	8305. 15
Boatswains' Chairs.....	8305. 16
Suspended Scaffolds.....	8305. 17
Needle Beam Scaffold.....	8305. 18

Ladder Specifications:

General.....	8306. 01
Single Rung Ladder.....	8306. 02
Single Cleat Ladder.....	8306. 03
Extension Ladders.....	8306. 04
Step Ladders.....	8306. 05
Sectional Ladders.....	8306. 06
Trestle Ladders.....	8306. 07
Extension Trestle Ladders.....	8306. 08

Painting:

Storage of Paints.....	8307. 01
Spray Painting.....	8307. 02

Electrical Wire and Apparatus:

General.....	8308. 01
--------------	----------

Blasting:

General.....	8309. 01
Transportation of Explosives.....	8309. 02
Handling of Explosives.....	8309. 03
Storage of Explosives.....	8309. 04
Drilling.....	8309. 05
Loading.....	8309. 06
Wiring.....	8309. 07
Firing.....	8309. 08
Inspection after Blasting.....	8309. 09
Misfires.....	8309. 10

Tools (in preparation):

Hand Tools.....	8311. 01
Power Operated Tools.....	8311. 02

(VII)

	Poisons and Harmful Substances (in preparation)	8312.00	Page
--	--	---------	------

Inflammables:

37	General	8313.01	60
38	Storage	8313.02	61
39	Handling and Use.....	8313.03	62

40	Hot Substances (in preparation)	8314.00	
----	--	---------	--

Welding, Cutting, Burning (in preparation):

41	Oxyacetylene	8315.01	
42	Electric	8315.02	

Machinery and Mechanized Equipment:

43	General	8316.01	64
44	Cranes, Hoists, and Derricks.....	8316.02	66
45	Woodworking Machinery	8316.03	68

Floating Plant:

46	Inspection	8317.01	70
47	Gangways, Guardrails, platforms, etc.....	8317.02	70
48	Machinery and Deckgear.....	8317.03	71
49	Miscellaneous.....	8317.04	73
50	Launches and Motorboats.....	8317.05	73
50	Drills	8317.06	74
51	Ring Buoys	8317.07	75
51	Skiffs	8317.08	76
52	Life Vests (Work Vests).....	8317.09	76
52	Fire Prevention and Protection.....	8317.10	77
53	Sanitation—Living Quarters.....	8317.11	78
54	Medical Supplies and First Aid.....	8317.12	79

Page
37
37
38
39
39
40
40
41
42
43

45
46
47
47
48
48
49
49

50
50

51

52
52
54
54
57
57
58
58
58
59

INFORMATION FOR CONTRACTORS

All contract work under the jurisdiction of the Corps of Engineers will be performed in compliance with the accident prevention manual entitled, "Safety Requirements for Excavation, Building and Construction," as established in the following accident prevention clause which is a part of all construction contracts.

(1) **Cost-Plus-a-Fixed-Fee Construction Contracts:** "*Accident Prevention*.—In order to protect the life and health of employees in the performance of this contract, the contractor will comply with all pertinent provisions of the 'Safety Requirements for Excavation, Building and Construction,' approved by the Chief of Engineers, December 16, 1941 (a copy of which is on file in the office of the Contracting Officer), and as may be amended, and will take or cause to be taken such additional measures as the Contracting Officer may determine to be reasonably necessary for this purpose. The contractor will maintain an accurate record of, and will report to the Contracting Officer in the manner and on the forms prescribed by the Contracting Officer, all cases of death, occupational disease, and traumatic injury arising out of or in the course of employment on work under this contract. The Contracting Officer will notify the contractor of any noncompliance with the foregoing provisions and the action to be taken. The contractor shall, after receipt of such notice, immediately correct the conditions to which attention has been directed. Such notice, when served on the contractor or his representative at the site of the work, shall be deemed sufficient for the purpose aforesaid. If the contractor fails or refuses to comply promptly, the Contracting Officer may issue an order stopping all or any part of the work. When satisfactory corrective action is taken, a start order will be issued."

(2) **Lump-Sum and Unit-Price Construction Contracts:** "*Accident Prevention*.—In order to protect the life and health of employees in the performance of this contract, the contractor will comply with all pertinent provisions of the 'Safety Requirements for Excavation, Building and Construction' approved by the Chief of Engineers, December 16, 1941 (a copy of which is on file in the office of the Contracting Officer), and as may be

(X)

amended, and will take or cause to be taken such additional measures as the Contracting Officer may determine to be reasonably necessary for this purpose. The contractor will maintain an accurate record of, and will report to the Contracting Officer in the manner and on the forms prescribed by the Contracting Officer, all cases of death, occupational disease and traumatic injury arising out of, or in the course of, employment on work under this contract. The Contracting Officer will notify the contractor of any noncompliance with the foregoing provisions and the action to be taken. The contractor shall, after receipt of such notice, immediately correct the conditions to which attention has been directed. Such notice, when served on the contractor or his representative at the site of the work, shall be deemed sufficient for the purpose aforesaid. If the contractor fails or refuses to comply promptly, the Contracting Officer may issue an order stopping all or any part of the work. When satisfactory corrective action is taken, a start order will be issued. No part of the time lost due to any such stop order shall be made the subject of claim for extension of time or for excess costs or damages by the contractor."

DEFINITIONS

8301.00

BUILDING AND CONSTRUCTION WORK

The phrase "Building and Construction work" shall mean and include the excavation, construction or erection, alteration and painting of buildings and other structures and all operations in connection therewith; the excavation, construction, alteration and repair of sewers and trenches, and all operations pertaining thereto.

SUBSTANTIAL

The term "Substantial" means construction of such strength, of such material and of such workmanship that the object referred to shall, under normal foreseen conditions or circumstances, withstand all reasonably expected wear, shock, usage and deterioration.

SECURELY FASTENED

The term "Securely Fastened" means that the subject or thing referred to shall be so secured in place that it cannot under normal foreseen conditions or circumstances be accidentally or unintentionally displaced, and that the object or thing referred to will be upheld and will withstand such weight or shock as is reasonably expected from normal use, condition or circumstances.

FACTOR OF SAFETY

The term "Factor of Safety" means the ratio between the ultimate breaking strength and the allowable safe unit working stresses of the material, structure or device. The term "Factor of Safety" of four (4) means that the material, structure or device shall be constructed of such strength that the ordinary imposed load will be one-fourth the ultimate breaking load. Where

(1)

other factors of safety appear herein, they shall apply in similar manner. Standard handbooks may be used in determining the strength of material.

EQUIPMENT

The term "Equipment" includes all the machinery, devices, tools, derricks, hoists, elevators, scaffolds, platforms, runways, ladders and all such facilities, safeguards and protective construction used in connection with construction operations.

LADDER

The term "Ladder" shall mean an appliance designed for use in ascending or descending at any angle exceeding fifty degrees with the horizontal, usually consisting of two side pieces called side-rails, joined at short intervals by cross pieces called rungs, cleats or treads. Any stairway rising at an angle steeper than 50 degrees from the horizontal will be considered a ladder.

FIXED LADDER

The term "Fixed" ladder shall mean a ladder substantially fastened in any fixed position.

SINGLE LADDER

The term "Single" ladder shall mean a ladder consisting of but one section.

EXTENSION LADDER

The term "Extension" ladder shall mean a ladder consisting of two or more sections traveling in guides or brackets so arranged that it may be adjusted to variable lengths.

STEP LADDER

The term "Step" ladder shall mean a ladder having flat treads and so constructed as to be self-supporting.

SECTIONAL LADDER

The term "Sectional" ladder shall mean a ladder consisting of two or more sections so constructed that the sections, when combined, will function as a single ladder.

"A" OR TRESTLE LADDER

The term "A" ladder or "Trestle Ladder" shall mean a ladder consisting of two single ladders hinged or joined at the top to form equal angles with the base.

EXTENSION TRESTLE LADDER

The term "Extension Trestle Ladder" shall mean a ladder consisting of an "A" or "Trestle" ladder with an additional vertical single ladder having parallel sides which is adjustable perpendicularly and is provided with a device to lock it into place.

WALL OPENINGS

The term "Wall Openings" shall mean openings in walls from which there is a clear drop of 6 feet or more, and shall include openings giving access to yard arms or block and tackle doorways and other openings 30 inches or more in height and 18 inches or more in width, the sill or lower edge of which is less than 18 inches above the floor or platform level. Open sides of building between columns, girders, or piers shall not be considered as wall openings.

PAINT MATERIALS

The term "Paint Materials" shall be defined as any material such as paint, varnish, shellac, stains, thinners, lacquers, dryers, size, varnish removers, bronzing liquids, enamels, colors dry or ground in oil, which are used for the preparation, finishing, decoration or protection of surfaces on buildings, structures or any parts thereof.

SCAFFOLD

The term "Scaffold" shall mean an elevated platform used for supporting workmen and/or material in connection with any of the operations coming within the scope of those requirements.

RUNWAY

The term "Runway" shall mean any aisle, walk, or drive constructed or maintained as a passageway for workmen or rolling equipment.

RAMP

The term "Ramp" shall mean an inclined runway.

MACHINERY AND MECHANIZED EQUIPMENT

"Machinery and Mechanized Equipment" shall mean an operating unit or a series of operating units, mobile or stationary, deriving its power for operation from a prime mover generated by wind, water, steam, electricity, compressed air, or internal combustion engine. The prime mover shall also be considered part of the operating unit.

ILLUSTRATIONS

The plates, figures, sketches, and illustrations shown herein and to which reference is made in the text shall not be construed as specifications but shall be considered as types for information or guides only in the construction of such equipment.

GENERAL REQUIREMENTS

SECTION 01—DRINKING WATER

8302.01

A. The dispensing of drinking water to employees shall be in accordance with the following procedure:

1. Drinking water will be obtained only from sources approved by Area or District Engineer.

2. Any of the following dispensing methods shall be used:

(a) Stationary bubbler with guarded orifice installed on approved water line.

(b) Fully enclosed water container and individual paper drinking cups.

(c) Portable sanitary drinking fountains meeting specifications of Procurement Division, Treasury Department.

3. Dipping water out of any container by individual cups, dippers, canteens, etc., is prohibited, and such containers must be provided with a covering so designed and fastened to prevent such use.

4. All containers used to furnish drinking water will be thoroughly sterilized at least once a week, and more frequently if circumstances require, by methods approved by competent medical authorities.

SECTION 02—TOILET FACILITIES

8302.02

A. For every 30 persons or less there shall be provided a privy or closet space so constructed that the occupant thereof will be shielded from view and protected against weather and falling objects. Each privy shall be provided with an adequate urinal trough.

B. At locations where a water-carriage sewerage system or chemical toilets are not available, the privy or closet space shall contain a fly-tight box constructed over a pit latrine or over pails or other suitable containers where pits are impracticable.

C. To render the box fly-tight, all cracks must be closed and the covers and hinges so arranged that the lids drop automatically; also there must be close contact between the base of the box and the ground. Additional fly proofing will be obtained by excavating an area 4 feet wide completely surrounding the pit to a depth of 6 inches. Cover this area with burlap soaked in crude oil, the burlap being placed so that it hangs down into the pit to a depth of 18 inches. The earth is then replaced over the burlap and tamped down. If burlap is not obtainable, the earth from excavated area may be mixed with crude oil and tamped back in place.

D. Each day the pit will be sprayed with crude oil, and the interior of both the box and the pit should be kept thoroughly coated with crude oil at all times.

E. The latrine seats will be scrubbed with soap and water daily, and washed off at least twice weekly with an antiseptic solution.

F. When the contents reach to within 2 feet of the top, pits will be filled with earth to within 6 inches of the surface and covered with a layer of sacking, soaked in crude oil, to extend 3 feet beyond the edges of the pit; the remainder of the pit will then be filled in with earth and the location marked.

(NOTE.—This is an adaption of Army Regulations on the subject.)

SECTION 03—FIRST AID STATIONS AND INFIRMARIES

8302.03

A. First Aid Kits:

1. On all projects employing less than 100 workers, 16-unit first aid kits shall be provided in the ratio of one for each 25 persons employed.

2. Each crew or part of crew working in areas where poisonous snakes are likely to be found shall be equipped with a snake-bite kit. Each snake-bite outfit shall contain:

- 1—plunger type suction syringe.
- 1—large suction cup for flat surfaces.
- 1—small round suction cup for small curved surfaces.
- 1—lancet sealed in glass or metal case.
- 3—ammonia inhalants.
- 3—iodine applicators.
- 1—tourniquet.
- 3—one-inch adhesive compresses.
- 1—tube syringe lubricant.

B. First Aid Field Station:

On all projects employing more than 100 and less than 300 persons, in a concentrated area, a first aid field station shall be established. First aid field stations shall provide a minimum of 100 square feet of floor space with provisions for adequate light, heat, and water; walls and ceilings shall be covered with nontoxic white paint, the floor shall be of impervious construction, and the exterior shall display appropriate insignia. Adequate directional signs shall be established on the project. First aid field stations shall be of the portable type so that they may be moved from one location to another to meet the needs of various working groups. Each station shall be equipped as follows:

- 2—enamel hand wash basins.
- 1—bandage scissors 7".
- 1—pint iodine in glass-stoppered bottle for dispensing purposes.

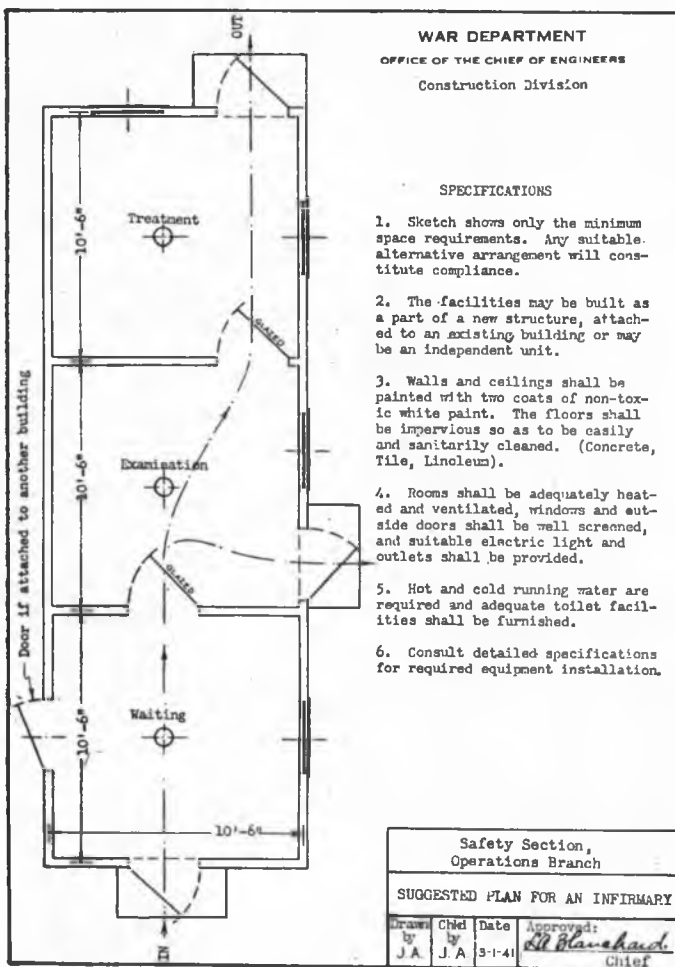

WAR DEPARTMENT
OFFICE OF THE CHIEF OF ENGINEERS
WASHINGTON
Construction Division

SPECIFICATIONS

1. Sketch shows only the minimum space requirements. Any suitable alternative arrangement will constitute compliance.
2. The station may be built as a knockdown unit if desired but it is recommended that it be constructed on skids so it may be readily moved from one location to another as the work demands.
3. Walls and ceiling shall be covered with two coats of non-toxic white paint. The floor shall be of impervious construction.
4. The room shall be adequately heated and ventilated, the windows and door shall be well screened, and suitable electric light and outlets shall be provided.

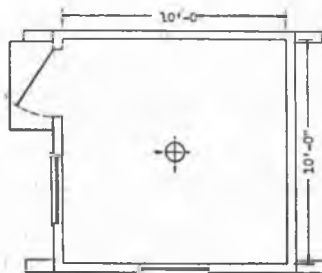

Plan

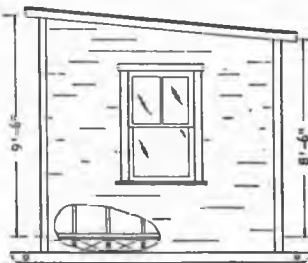

Elevation

Safety Section
Operations Branch

SUGGESTED PLAN FOR A
PORTABLE FIRST AID STATION

Revised
5-1-42.

Approved:
L. G. Blanchard
Chief, Safety Section.

SP9CL-5

- 1—dozen each 1" and 2" bandage and sterile dressings, 2" x 2" and 4" x 4".
- 1—bundle absorbent cotton.
- 1—foot rest.
 - adhesive tape, ½" and 1".
 - aromatic spirits of ammonia.
 - assorted safety pins.
 - applicators.
 - tourniquet.
 - stretcher and blankets.
 - alcohol, ether, benzol, or gasoline, if these substances are to be used in cleaning wounds (gasoline containing no tetra-ethyl lead).
 - band aids.

C. Infirmary:

On all projects employing 300 to 1,000 persons, an infirmary shall be established having a minimum floor space of 300 square feet for 300 employees and an additional 100 square feet of floor space for each additional 300 employees. This shall consist of one room units with a minimum of four rooms for projects employing 1,000 persons. The infirmary shall be so constructed as to provide reasonable quiet, privacy, good ventilation, light and heat, adequate toilet facilities, hot and cold running water, drainage, electrical outlets, and impervious floors (lineoleum, concrete or tile). Walls and ceilings shall be painted with two coats of white paint (nontoxic) and windows and doors shall be properly screened. Telephone service shall be maintained in the infirmary or immediately adjacent thereto. The infirmary shall be so located on the project that no person will be required to walk a prohibitory distance for treatment. The infirmary shall be well marked with appropriate insignia. Adequate directional signs shall be located at various points throughout the project.

1. The following equipment shall be made available for infirmaries on projects employing 1,000 persons:
 - 1—glazed sink with hot and cold running water.
 - 1—smooth top table, size 2' x 3' or 3' x 4'.
 - 1—clock.
 - 2—chairs or stools.
 - benches for waiting room.

- 1—cot or couch covered with washable material.
 - recovery cots: 1 per 1,000 men employed; 1 per 30 women employed, screened.
- 2—blankets (dark) wool per cot.
- 1—splint, Thomas type for arm (may be kept in main dressing room only).
 - cabinets for supplies.
- 1—abridged textbook on first aid. Industrial edition. American Red Cross, By Col. C. Lynch and Lt. Col. M. S. Shields, (latest edition).
- 1—foot rest.
- 1—stretcher.
 - soda mint tablets.
- 2—rubber-covered washable pillows.
- 2—enamel hand wash basins.
- 1—pus basin (kidney shaped).
- 1—waste pail, covered.
- 1—hot water bottle.
- 1—stretcher.
- 1—(or more) screens, folding type of light construction.
- 1—desk, chair, and file.
 - individual towels, drinking cups, soap.
- 1—liquid soap dispenser (optional).
- 1—flash light.
- 1—bandage scissors 7".
 - bottles of assorted sizes of solutions.
- 1—clinical thermometer.
- 6—eye droppers.
- 1—tourniquet.
 - splints wood (yucca).
- 1—splint, Thomas type for leg (may be kept in main dressing room only).
 - zinc oxide ointment, $\frac{1}{2}$ lb. (optional).
 - butesin picrate ointment in tubes (optional).
 - aspirin tablets (for minor complaints only).
 - boric acid, 1 lb.
 - magnesium sulphate, 1 lb.
 - hand brushes.
 - tincture of iodine.
 - bandages, 1" and 2 $\frac{1}{2}$ ", several dozen of each.
 - sterile dressing, 2' x 2', 4' x 4' and fluffs.
 - absorbent cotton, 1 lb.

- adhesive tape, $\frac{1}{2}$ "", 1", and 3" sizes (quantity depending on demand).
- aromatic spirits of ammonia.
- assorted safety pins.
- applicators and tongue depressors.
- bichloride of mercury tablets (safety type) for antiseptic solution.
- tincture of green soap (optional).
- scarlet red ointment, $\frac{1}{4}$ lb. (optional).
- alcohol.
- gasoline (containing no tetra-ethyl lead), benzol, ether (optional).

2. Equipment for infirmaries on projects employing more than 1,000 persons shall include the foregoing and the following:

- 1—binocular loupe.
- 1—eye spud.
- 1—head mirror.
- 1—gasoline or benzol dispenser if this substance is to be used in the cleansing of wounds.
- 1—sterilizer and heating device, electric.
- 1—emergency table, size $6\frac{1}{2}$ ' by $2\frac{1}{2}$ ' by 3' high with rubber covered cushion (expensive operating table not required).
- 1—rubber sheet (heavy) $1\frac{1}{2}$ yds. square.
 - soaking tanks or basins.
 - inexpensive X-ray equipment for installations for 1,000 to 2,000 employees or over (depending on availability and need).
- 1—surgical scissors, straight, $5\frac{1}{2}$ "".
- 1—surgical scissors, curved, $5\frac{1}{2}$ "".
- 2—scalpels.
- 1—tissue forceps, 5".
- 1—thumb forceps, 5".
- 3—hemostatic forceps, Kelly's catgut and needles, assorted sizes.
 - other physical therapy equipment (heat lamps, etc.) depending on local conditions and choice of physician in charge.
- 1—hair clipper.
 - skin sutures.
 - rubber gloves.

1—safety razor and blades.

1—needle holder 5".

3. On projects employing more than 1,000 persons, the infirmary shall be supplemented by first aid field stations in accordance with the following employment table:

Number of employees:	<i>Number of first aid stations</i>
1,000 to 2,000.....	1
2,000 to 3,000.....	2
3,000 to 4,000.....	3
4,000 to 6,000.....	4
6,000 to 8,000.....	5
8,000 to 10,000.....	6
10,000 to 12,000.....	7
12,000 to 15,000.....	8

D. Personnel, Qualifications and Duties:

1. *Full Time Physicians.*—All projects employing 1,000 persons or more shall have the full time services of a physician who shall be a graduate of a Class "A" medical school and be duly licensed to practice medicine in the State. The duties of the full time physician shall be: (1) Responsibility for supervision of the infirmary and first aid stations, all medical and first aid services and facilities; (2) Render such medical attention as may be necessary beyond the scope of registered nurses and first aid personnel; (3) Arrange for the proper care and transportation of sick and injured persons to such necessary facilities as are not available on the project.

2. *Registered Nurses.*—Full time registered nurses shall be assigned to each project requiring an infirmary. The duties of the nurses shall be to care for the sick and injured as come within their scope of training and ability under the supervision of a physician, and they shall be responsible for the proper maintenance of the infirmary and equipment. The nurse personnel shall be determined in accordance with the following table:

Number of employees:	<i>Number of nurses</i>
300 to 2,000.....	1
2,000 to 3,000.....	2
3,000 to 4,000.....	3
4,000 to 5,000.....	4
5,000 to 7,000.....	5
7,000 to 9,000.....	6

The above tables are minimum requirements and where conditions are of an extraordinary nature, the District or Area Engineer shall determine such additional facilities as may be necessary to adequately and efficiently care for injured employees.

3. *First Aid Attendants.*—All first aid shall be administered and all field stations manned by first aid attendants (or registered nurses) holding a current certificate in standard first aid issued either by the American Red Cross or the United States Bureau of Mines. First aid attendants will be limited to first aid field treatments and shall not clean up serious wounds, set fractured bones, remove imbedded foreign bodies (especially from the eye) nor administer drugs. First aid attendants shall promptly and properly transfer to the infirmary all persons suffering other than very minor injuries. First aid attendants shall promptly arrange for all persons suffering from other than very minor injuries to be placed under the care and treatment of a qualified physician.

E. Ambulance Service:

Ambulance service shall be established and maintained on all projects located more than two miles from local ambulance service; projects within that distance shall make arrangements with the local ambulance service. This provision may be modified where there are a relatively small number of men employed or the nature of the work is such that the exposure to serious accidents is slight.

Notices of all available local medical, hospital and ambulance service shall be posted in the infirmaries and first aid field stations.

F. Record of Infirmary and First Aid Treatment:

A daily record of all treatments in infirmaries and first aid field stations shall be maintained. In compliance with the foregoing, the following data are required:

Date.	Name of Employer.
Time injured arrived and left.	Foreman's Name.
Case Number.	Description of Accident.
Name of Employee.	Nature of Injury.
Badge Number.	Treated by.
Employee's Occupation.	Treatment Given.
	Lost Time.

These complete records shall be kept on file at infirmaries and first aid stations and made available for frequent inspections.

SECTION 04—PROTECTIVE EQUIPMENT AND PRACTICES 8302.04

A. Chipper's goggles, welder's goggles, welder's shields, hard hats, rubber boots, safety belts, life lines, life nets, life preservers or jackets, respirators and such other protective equipment and/or clothing, occasioned by the type of work being done, shall be furnished, maintained in serviceable condition, made available to employees and its use enforced.

B. Tetanus antitoxin will not be administered to any injured worker without first making the usual skin test to determine reaction to the serum. If a positive reaction develops and antitoxin is still necessary, the injured shall be desensitized in accordance with the circumstances indicated.

SECTION 05—LIGHTING 8302.05

A. Stairways, corridors, passageways, and working areas shall be kept reasonably and adequately lighted while work is in progress.

B. Where working conditions require the use of artificial lighting it shall be maintained after a shift until workmen have had an opportunity to leave the premises.

SECTION 06—GAS AND SMOKE 8302.06

A. No means or agency of heat or heating shall be used which releases smoke or gas within an enclosure where workers are employed.

B. No fire or open flame shall be permitted on a project without the approval of the foreman or person in charge.

C. Where smoke pipes from stoves or other heating apparatus pass through combustible walls or roofs, proper insulating sleeves shall be provided.

D. All stoves and other heating apparatus shall be mounted on a fireproof base and have proper fire protection at the rear and sides.

SECTION 07—SALAMANDERS 8302.07

A. Salamanders or other direct fired heaters shall be properly covered and exhaust piped to the outside air.

B. When salamanders are used in inclosed spaces, proper tests for carbon monoxide shall be made and such areas freed of all harmful or toxic gases and fumes before workmen are permitted to enter.

SECTION 08—ACCIDENT REPORTING

8302.08

A. Each accident involving an employee of a contractor resulting in death, permanent total or permanent partial disability or other injury, or occupational disease, arising out of or in the course of employment, which prevents the employee from returning to work on the next calendar day or regular shift, will be promptly reported to the Contracting Officer on Form ED-401.

SECTION 09—EMPLOYMENT OF SAFETY ENGINEER

8302.09

A. Any contractor employing 1,000 or more persons shall provide the services of a qualified Safety Engineer who shall devote full time to accident prevention among his employees engaged on the site.

SECTION 10—TRANSPORTING PROJECT PERSONNEL

8302.10

A. Trucks while being used to transport project personnel shall be equipped with a seating arrangement and a rear-end gate, closed and securely fastened.

B. Only one person shall be permitted to ride in the cab seat with the truck driver. Brakes shall be inspected weekly.

C. Under no circumstances shall workers or others be permitted to ride with their arms or legs outside of truck body; in a standing position in the body, on running boards, seated on side fenders, rear of truck, or on the load.

D. Bodies of dump trucks shall be made fast to chassis while being used to transport a human load. They shall be securely fastened by a rope, chain or equivalent in addition to the the normal locking device.

E. Provision shall be made to stow securely, tools and equipment while being transported with a human load.

F. No one shall be permitted to get on or off any motor vehicle while it is in motion.

SECTION 11—STORING MATERIALS AND DISPOSAL OF WASTE 8302.11

A. Materials which in the course of building construction are to be stored in locations at or near which workers are employed shall be piled or stacked in an orderly manner to avoid toppling over or being otherwise displaced.

B. No material shall be piled or stacked to a greater height than 6 feet, except in yards or sheds intended especially for storage.

C. When piles exceed 4 feet in height the material shall be placed so that the sides and ends of the piles taper back.

D. All boards, planks, blocks, and other material and debris containing projecting nail points, and waste clippings or cuttings of lumber, metal (including pieces of sheet metal, pipe, metal lath, rolled shapes, wire), masonry materials and similar objects shall be *continually removed* from working areas or shall be placed in orderly piles where workmen will not be likely to step or stumble over or fall on them.

E. All stairways, corridors and passageways shall be kept free from loose material and debris.

F. Floors, roofs, and structures shall not be overloaded in the storage and use of materials and equipment.

FRONT FORM ED-401

FORM ED-401
JULY 1942
CONSTRUCTION DIVISION
OPERATIONS BRANCH
SAFETY SECTION

WAR DEPARTMENT
OFFICE OF THE CHIEF OF ENGINEERS
REPORT OF OCCUPATIONAL INJURY

DISTRICT St. Louis

DIVISION Upper Miss. Valley

STATION Illinois Grd. Plant

LOCATION Carbondale, Ill.

<input type="checkbox"/> GOVERNMENT EMPLOYEE		<input checked="" type="checkbox"/> CONTRACTOR'S EMPLOYEE	
MILITARY CONSTRUCTION			
<input type="checkbox"/> AIR CORPS FACILITIES	<input type="checkbox"/> CHEMICAL PLANT	<input type="checkbox"/> DREDGING	<input type="checkbox"/> BRIDGES
<input type="checkbox"/> INDOOR FACILITIES	<input type="checkbox"/> POST FACILITIES	<input type="checkbox"/> AIRFIELD LINES	<input type="checkbox"/> AIRFIELD OFFICES
<input type="checkbox"/> GENERAL HOSPITAL	<input type="checkbox"/> OTHER STORAGE	<input type="checkbox"/> LOGS & DAMS	<input type="checkbox"/> DAMS
<input type="checkbox"/> FURNISHING PLANT	<input type="checkbox"/> MISCELLANEOUS	<input type="checkbox"/> MILITARY BARRACKS	<input type="checkbox"/> MILITARY BARRACKS
<input type="checkbox"/> SHIP STORAGE, ETC.	<input type="checkbox"/> POST ENGR. OPERATIONS	<input type="checkbox"/> DISTRICT OR DIVISION OFFICE PERSONNEL	<input type="checkbox"/> CIVIL WORKS (E.C.)

DO NOT WRITE IN THIS SPACE

SECTION 1	NAME <u>Bryant Purley</u> SEX <u>M</u> AGE <u>44</u> RACE <u>W</u>	
SECTION 2	ADDRESS <u>845 Wilson Chicago, Ill.</u> MARRIED <u>Yes</u> SEX <u>M</u>	
SECTION 3	OCCUPATION <u>Sheet Metal Worker</u> YEARS OCCUPATIONAL EXPERIENCE <u>17</u> WEEKS ON THIS JOB <u>3</u>	
SECTION 4	DATE <u>July 13</u> TIME <u>2</u> HOUR <u>10:00</u> AM (SUPERVISOR <u>V. W. Rorow</u>)	
SECTION 5	EXACT LOCATION OF ACCIDENT (DESCRIBE) <u>Area 2F, Building 2. Fuse line building on platform under rafters.</u>	
SECTION 6	NATURE OF INJURY <u>Compound fracture of skull</u>	
SECTION 7	ATTENDING PHYSICIAN <u>W. D. Gardner</u> PART OF BODY AFFECTED <u>Head</u>	
SECTION 8	PLACE OF TREATMENT <u>Herrin Hospital</u> TREATMENT <u>Blood plasma given.</u>	
SECTION 9	RESULTS: <input checked="" type="checkbox"/> DEATH... DATE <u>7/13/42</u> ... HOURS DAYS <input type="checkbox"/> PERMANENT TOTAL DISABILITY... DATE STARTED LOSING TIME <input type="checkbox"/> PERMANENT PARTIAL DISABILITY... DAYS <input type="checkbox"/> LOSS OF USE OF MEMBER... TOTAL NUMBER DAYS LOST	
SECTION 10	WHAT MACHINE, TOOL, OBJECT, OR MATERIAL WAS THE AGENCY OF INJURY? <u>Temporarily nailed cross brace.</u>	
SECTION 11	WHAT PART OF MACHINE, TOOL, ETC.? <u>None</u>	
SECTION 12	IF MACHINE, CHECK WHETHER POWER WAS <input type="checkbox"/> MOTOR VEHICLE <input type="checkbox"/> IN MOTION <input type="checkbox"/> OTHER MECHANICAL <input type="checkbox"/> NOT IN MOTION <input type="checkbox"/> NON-MECHANICAL	
SECTION 13	WHAT JOB WAS <input checked="" type="checkbox"/> INJURED PERSON <input type="checkbox"/> OTHER PERSON DOING WHICH WAS MOST CLOSELY ASSOCIATED WITH ACCIDENT? <u>Installing sheet metal ventilating duct in eaves of roof.</u>	
SECTION 14	TYPE OF ACCIDENT <input type="checkbox"/> FALLS OF PERSONS—SAME LEVEL <input checked="" type="checkbox"/> FALLS OF PERSONS—ONE LEVEL TO ANOTHER <input type="checkbox"/> SLIPS (CAUSING STRAINS, ROY FALLS) <input type="checkbox"/> FALLING, SLIDING, FLYING OBJECTS <input type="checkbox"/> CAUGHT IN OR BETWEEN <input type="checkbox"/> STRUCK BY OR RUN OVER BY VEHICLE <input type="checkbox"/> STRUCK AGAINST, STEPPING IN OR ON <input type="checkbox"/> DROWNING OR IMMERSION <input type="checkbox"/> BURNING OR SCALDING <input type="checkbox"/> ELECTRICAL SHOCK <input type="checkbox"/> INHALATION, ABSORPTION, SWALLOWING <input type="checkbox"/> POISONING, INFECTION <input type="checkbox"/> OTHER TYPE OF ACCIDENT (SPECIFY)	
SECTION 15	EXPLANATION <u>Fatal — no statement possible.</u>	

BACK
FORM ED-401

SECTION I WITNESSES	NAME _____ ADDRESS _____ John Pretto _____ Murphysboro, Ill. Claude Royce _____ Marion, Ill. Lawrence Wachtel _____ Herrin, Ill.	
SECTION I STATEMENT	EXPLANATION OF ACCIDENT: Bryant had instructed carpenter to lower cross brace to make room for duct. Cross brace only tacked in position. Bryant standing on 13' platform, stepped on 6"x6" cross support and caught cross brace to pull himself up. Brace came loose and Bryant fell to concrete floor. /s/ C. W. Royce Foreman	66-67 <input type="checkbox"/>
	RECTIONS I & II TO BE FILLED IN BY SAFETY ENGINEER CAUSES OF THE ACCIDENT <small>These checkboxes should be made in duplicate. Check the box which best describes the cause of the accident. In each section the cause which caused the accident is the one most nearly nearest the meaning of what would have helped most to prevent the accident. Use an arrow to show the cause to which you wish to refer in your report to indicate your interpretation of cause.</small>	
SECTION I UNSAFE PRACTICES	SUPERVISOR: A SUPERVISOR <input type="checkbox"/> WAS <input checked="" type="checkbox"/> WAS NOT AT THE SCENE AND DIRECTING OPERATIONS <input type="checkbox"/> ASSIGNED EMPLOYEE TO IMPROPER JOB <input type="checkbox"/> FAILED TO INSPECT FOR HAZARDS <input type="checkbox"/> GAVE INSUFFICIENT INSTRUCTIONS OR TRAINING <input type="checkbox"/> FAILED TO ENFORCE SAFETY REGULATIONS <input type="checkbox"/> ASSUMED IMPROPER ATTITUDE <input type="checkbox"/> OTHER (SPECIFY) _____ Did not require braces to be permanently fastened.	68 <input type="checkbox"/> 69 <input type="checkbox"/> 70-71 <input type="checkbox"/>
SECTION II UNSAFE CONDITIONS	EMPLOYEE: <input type="checkbox"/> INJURED PERSON <input type="checkbox"/> OTHER PERSON <input type="checkbox"/> INJURED PERSON <input type="checkbox"/> OTHER PERSON <input type="checkbox"/> FAILURE TO OBEY INSTRUCTIONS <input type="checkbox"/> FAILURE TO USE SAFETY DEVICES OR MAKING THEM IMPROPERATIVE <input type="checkbox"/> OPERATING OR DOING WITHOUT AUTHORITY <input type="checkbox"/> USING DEFECTIVE HAND TOOLS, EQUIPMENT, MACHINERY OR MATERIALS <input type="checkbox"/> DELIBERATE CHARGE TAKING <input type="checkbox"/> CARELESSNESS <input type="checkbox"/> DISTRACTED ATTENTION <input type="checkbox"/> USING IMPROPER HAND TOOLS, EQUIPMENT, MACHINERY OR MATERIALS <input type="checkbox"/> FAILURE TO REPORT UNSAFE CONDITIONS <input type="checkbox"/> UNSAFE LOADING, UNLOADING, STORING OR HANDLING <input type="checkbox"/> FAILURE TO WARN OTHERS <input type="checkbox"/> LACK OF KNOWLEDGE OR SKILL <input type="checkbox"/> OPERATING OR WORKING AT UNSAFE SPEED <input type="checkbox"/> WORKING ON MOVING OR DANGEROUS MACHINERY <input type="checkbox"/> OTHER (SPECIFY) _____ Man was worrying about a law suit.	72 <input type="checkbox"/> 73-74 <input type="checkbox"/>
SECTION II UNSAFE CONDITIONS	<input type="checkbox"/> IMPROPER GUARDING (EXPLAIN) _____ <input checked="" type="checkbox"/> DEFECTIVE OR IMPROPER SUBSTANCE OR EQUIPMENT (EXPLAIN) _____ temporarily tacked brace used as a support. <input checked="" type="checkbox"/> HAZARDOUS ARRANGEMENT (EXPLAIN) Scaffold not high enough at end where man was working. <input type="checkbox"/> IMPROPER ILLUMINATION (EXPLAIN) _____ <input type="checkbox"/> IMPROPER VENTILATION (EXPLAIN) _____ <input type="checkbox"/> PROTECTIVE DEVICES (EXPLAIN) _____ <input type="checkbox"/> IMPROPER DRESS OR APPAREL (EXPLAIN) _____ <input type="checkbox"/> PHYSICAL OR MENTAL DEFECT (EXPLAIN) _____ <input type="checkbox"/> OTHERWISE CLASSIFIED (EXPLAIN) _____	75 <input type="checkbox"/> 76-78 <input type="checkbox"/>
SECTION II RECOMMENDATIONS	EMPLOYER'S FIRM NAME: Charles E. Crane & Co. /s/ G. E. Wagner TITLE Safety Engineer	79-80 <input type="checkbox"/>
SECTION II RECOMMENDATIONS	CAUSE OF ACCIDENT: Man stepped from platform to cross support and grabbed temporarily tacked cross brace for support—brace pulled loose. IF CAUSE IS A VIOLATION OF "SAFETY REQUIREMENTS", STATE CODE NO. None WHAT STEPS HAVE BEEN TAKEN TO PREVENT REOCCURRENCE OF SUCH INJURIES: Braces will be removed or permanently fastened. Men cautioned against such unsafe acts. OCCUPATION NO. (FROM FORM ED-401) 6 /s/ Milton Horn	81-82 <input type="checkbox"/> 83-85 <input type="checkbox"/>
	<input checked="" type="checkbox"/> DISTRICT ENGINEER <input type="checkbox"/> APPROVED <input type="checkbox"/> POST ENGINEER (R.B.U.) <input type="checkbox"/> DISAPPROVED DATE 7/31/42 /s/ John Doe, Jr.	<input type="checkbox"/> DIVISION ENGINEER <input type="checkbox"/> APPROVED <input type="checkbox"/> DISAPPROVED DATE 8/3/42 /s/ John Doe

SPECIFIC REQUIREMENTS

STEAM BOILERS

SECTION 01—INSPECTION

8303.01

A. Steam boilers and all other fired or unfired pressure vessels, having a volume of more than 5 cubic feet and carrying in excess of 15 pounds pressure, shall be inspected by a licensed inspector and approved certificate posted before such equipment is put into operation. Marine and locomotive boilers are included.

Subsequent inspections shall be made at intervals not exceeding 12 calendar months unless otherwise required. Stationary boilers which have been removed, repaired, or overhauled during the 12 calendar months for which approved certificates have been issued shall be inspected by a licensed inspector and a new approved certificate bearing the date of inspection attached thereto before being put into operation. Mobile boilers which have been repaired or overhauled during the 12 calendar months for which approved certificates have been issued shall be inspected by a licensed inspector and a new approved certificate bearing the date of inspection attached thereto before being put into operation. Safety valves, gages, injectors, and other appliances attached to and used in connection with boilers shall be interpreted as part of the boiler except that replacements of such appurtenances adjusted in accordance with approved certificate shall not be interpreted as boiler repairs.

B. Fusible plugs shall be provided on all boilers and shall be renewed annually.

C. Approved type safety or relief valves shall be provided on all boilers and pressure vessels. No valve shut-off shall be placed between the boiler or pressure vessel and the safety or relief valve.

D. Safety or relief valves, after being adjusted by the inspector, shall be properly sealed.

E. Safety valves shall be tested at least once a day by raising steam to the popping pressure of the valve. When steam pressure rises to more than 5 pounds above the set pressure before popping, the boiler shall be taken out of service and the safety valve inspected and readjusted.

F. All boiler feed lines shall be equipped with check valves placed as close as possible to the boiler.

G. All boilers shall be equipped with approved blow-off cocks or valves. The blow-off line shall be arranged so that leakage can be observed by the operator. All pressure vessels shall be equipped with a drain valve located at the bottom of such vessel.

H. The discharge from safety valves, relief valves, and blow-offs shall be located so that they do not constitute a hazard to workmen.

I. When cracks, leaks, blisters, or other serious defects develop, boilers or pressure vessels shall be taken out of service immediately.

J. Repairs shall not be made while a boiler or pressure vessel is under pressure.

K. Spark arresters shall be used on all boiler stacks when necessary.

L. Provisions of the ASME Power Boiler Code will generally apply.

EXCAVATION

SECTION 07—EXCAVATIONS

8304.07

A. The sides of excavation 5 feet or more in depth shall be supported by substantial and adequate sheeting, sheet piling, bracing, shoring, etc., or the sides sloped to the angle of repose. Substantial and adequate sheeting, sheet piling, bracing, shoring, etc., shall be based upon calculations of pressures exerted by and the condition of the materials to be retained.

B. Foundations, adjacent to where excavation is to be made below the depth of the foundation, shall be supported by shoring, bracing, or underpinning as long as the excavation shall remain open.

C. Excavated or other material shall not be stored nearer than 2 feet from the edge of the excavation.

D. Bridges or walkways with guard rails shall be provided where men or equipment must cross over trenches, ditches, etc. A temporary guard railing or other effective guard or barricade shall be provided at or near the edge of an excavation as soon as possible, except where the installation of such safeguard will interfere with the excavation or other work.

E. Red lights or torches, maintained from sunset to sunup, shall be placed on excavation barricades and along the sides of unbarricaded excavations which are exposed to paths, walkways, sidewalks, driveways, or thoroughfares.

F. Materials used for sheeting and sheet piling, bracing, shoring, and underpinning, shall be in good serviceable condition and timbers used shall be sound, free from large or loose knots, and of the required dimensions. The material specifications are the minimum requirements and the spacing of material members is the maximum allowable in securing trenches against slips, cave-ins, and slides. Where conditions are encountered which require materials of greater strength or closer spacing of timbers to hold the soils securely in place, the sizes of timbers in such cases shall be increased to compensate for the overload.

SECTION 08—TRENCH EXCAVATION

8304.08

A. The following provision for shoring and bracing of trenches shall not apply where solid rock, hard slag, or hard shale is encountered or in which employees are not required to be or to work.

B. The sides of trenches in material, other than those listed in paragraph F, which are 5 feet or more in depth and 8 feet or more in length shall be securely held by shoring and bracing, or sloped to the angle of repose of the material being excavated.

C. If the unit tunnel method is used, the length of earth left in place between the separate unit trenches shall be not less than one-half the depth of the trench and shall be considered as taking the place of shoring and bracing.

D. Whenever or wherever the unit tunnel method is used and where there is apparent danger of slips, slides, or cave-ins, trenches or tunnels in which men are employed shall be shored and braced or otherwise retained as may be necessary to prevent caving.

E. Trenches over 8 feet in length and 5 feet or more in depth in hard compact material, shall be braced at intervals not exceeding 8 feet, with 2-inch by 6-inch planks, or heavier material, placed vertically in the trench opposite each other, backed up by 2-inch by 10-inch planks bearing against the walls at the same intervals as cross braces, struts, or trench jacks. These braces shall, if possible, extend to the bottom of the trench and be supported by horizontal cross braces or struts. Bracing and shoring of trenches shall be carried along with the excavation and must in no case be omitted, except where a mechanical digger is used, the shoring shall be placed within 6 feet of the lower end of the boom. Undercutting shall not exceed 6 inches on either side of the trench.

F. Trenches in partly saturated, filled or unstable soils or where running material is encountered, such as quicksand, loose gravel, loose shale, or completely saturated material, the sides of the trenches 4 feet or more in depth shall be secured by the use of continuous vertical sheet piling and suitable braces. In trenches over 4 feet in depth wooden sheet piling shall be not less than 2 inches in thickness.

G. Sheet piling shall be held in place by longitudinal beams at vertical intervals of 4 feet. The longitudinal beams shall in turn be supported by the cross braces or struts spaced a maximum of 4 feet. The longitudinal beams shall be in no case less in strength than that of a 4- by 4-inch beam; and when the longitudinal distance between cross braces or struts exceeds 4 feet and less than 6 feet, the longitudinal beam shall be not less than a 4- by 6-inch beam.

H. Vertical braces and longitudinal beams in trenches shall be supported by horizontal cross braces or struts, screw jacks, or timber placed at right angles to both braces, cleated and rigidly screwed or wedged. The timbers or struts shall be not less in strength than the following trade sizes:

Width of trench:	<i>Size of cross braces or struts</i>
1 foot to 3 feet-----	4 x 4 inches
3 feet to 6 feet-----	4 x 6 inches
6 feet to 8 feet-----	6 x 6 inches

I. One horizontal cross brace or strut shall be required for each 4 feet of depth or major fraction thereof.

J. In case it is desired to increase the vertical spacing between longitudinal beams or cross struts, the longitudinal beams, cross struts, and vertical sheet piling shall be increased in size to compensate for the overload.

K. Additional precautions by way of shoring and bracing shall be taken to prevent slides, or cave-ins, when excavations or trenches are made in locations adjacent to backfilled excavations or subjected to vibrations from railroad or highway traffic, the operation of machinery, or any other source.

L. Ladders, extending from the floor of trench excavation to not less than 3 feet above the top ground surface, shall be placed in the trench excavation at 50-foot intervals to be used as a means of entrance and exit therefrom.

ROPES, CABLES, CHAINS

SECTION 09—ROPES, CABLES, CHAINS

8304.09

A. Fiber ropes used to support a human load shall be inspected before each use. Visual inspection shall be made for abrasion, broken fibers, cuts, fraying, or any other defects. Fiber ropes found to have defects under such inspection and examination shall be removed from such service.

B. Ropes, cables, and chains shall not be used for stresses in excess of the allowable stresses given for each in the table—Safe Loads For Ropes and Chains.

C. Wire ropes or cables shall be inspected at the time of installation and once each week thereafter, when in use, and removed from hoisting or load-carrying service when any one of the following conditions exist:

Defects Which Require Wire Ropes To Be Removed From Load-Carrying Service

- (1) When three broken wires are found in one strand of 6 x 7 wire rope;
- (2) When six broken wires are found in one strand of 6 x 19 wire rope;
- (3) When nine broken wires are found in one strand of 6 x 37 wire rope;
- (4) When eight broken wires are found in one strand of 8 x 19 wire rope;
- (5) When marked corrosion appears;
- (6) Wire rope which has been idle for 3 months or more and subjected to water, moisture, dampness, etc., shall be cut off and inspected for internal corrosion, and if marked corrosion is found it shall be removed from hoisting or load-carrying service;
- (7) Wire rope not mentioned herein, shall be removed from load-carrying service when 4 percent of the total number of wires composing such rope are found to be broken.

D. Wire ropes or cables removed from service under the requirements in items (1) to (7), inclusive, shall not be placed in service again on hoists, cranes, or other such equipment.

E. The ratio between the rope diameter and the block, sheave, or pulley tread diameter shall be such as to allow the rope strands to slide past each other and adjust themselves to the bend. The economical and absolute critical sheave diameters for steel ropes to be considered for any operating rope are shown in the following table. The "Economical Minimum" sheave diameters should be used for all operating hoist ropes. In no case shall the sheave diameter be less than the "Absolute Critical" sheave diameter for any operating ropes as specified below. For cable sizes not mentioned herein, see manufacturers' specifications for corresponding block, sheave, and pulley diameters:

Economical and Critical Sheave Diameters for Operating Ropes

Sizes	6 x 7	6 x 19	6 x 37	8 x 19
"Economical Min." dia. for operating hoist ropes.....	36D	24D	16D	20D
"Absolute Critical" dia. for any rope.....	28D	16D	14D	14D

NOTES.—(1) D—Tread Diameter of Sheaves.

(2) Sheaves or pulleys with eccentric bores or cracked hubs, spokes, or flanges shall be removed from service.

F. Connections, fittings, fastenings, parts, etc., used in connection with ropes, cables, or chains shall be of such quality and strength and so attached, connected, fastened, etc., as to provide a safety factor of not less than four. Manufacturers' standard connections shall be used.

G. Running lines of hoisting equipment, located within 6 feet 6 inches from the ground or working level, shall be boxed, railed off, or otherwise guarded, or the operating area restricted, except when loads are moved horizontally.

Safe working load in pounds for single new sling ropes and chains

NOTE.—The safe operating loads in these tables are for each *single* rope or chain. When used double or in other multiples the loads may be increased in direct proportion.

Diagrams showing how the angle of a sling alters the safe carrying capacity of a load

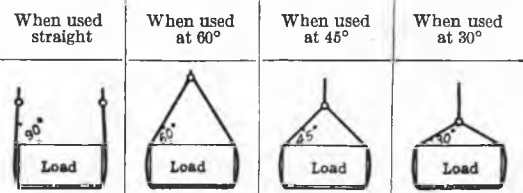

26

TABLE I.— <i>Plow steel wire rope</i> (6 strands of 19 or 37 wires) If crucible steel rope is used the load must be reduced one-fifth	Diameter	When used straight	When used at 60°	When used at 45°	When used at 30°
	3/8"-----	1,500	1,275	1,050	750
1/2"-----	2,400	2,050	1,700	1,200	
5/8"-----	4,000	3,400	2,800	2,000	
3/4"-----	6,000	5,100	4,200	3,000	
7/8"-----	8,000	6,800	5,600	4,000	
1"-----	10,000	8,500	7,000	5,000	
1 1/8"-----	13,000	11,000	9,000	6,500	
1 1/4"-----	16,000	13,500	11,000	8,000	
1 3/8"-----	19,000	16,000	13,000	9,500	
1 1/2"-----	22,000	19,000	16,000	11,000	

TABLE II.— <i>Crane chain</i> (Best grade of wrought iron, hand-made, tested, short link chain)	Diam. of Iron				
	1/4"-----	600	500	425	300
3/8"-----	1,200	1,025	850	600	
1/2"-----	2,400	2,050	1,700	1,200	
5/8"-----	4,000	3,400	2,800	2,000	
3/4"-----	5,000	4,700	3,900	2,750	
7/8"-----	7,500	6,400	5,200	3,700	
1"-----	9,500	8,000	6,600	4,700	
1 1/8"-----	12,000	10,200	8,400	6,000	
1 1/4"-----	15,000	12,750	10,500	7,500	
1 3/8"-----	22,000	19,000	16,000	11,000	

TABLE III.— <i>Hemp or manila rope</i> (Best long fiber grade)	Circum.	Diameter				
	1"-----	3 1/2"-----	120	100	85	60
1 1/2"-----	1 1/2"-----	250	210	175	125	
2"-----	5/8"-----	360	300	250	180	
2 1/2"-----	3/4"-----	520	440	360	260	
3"-----	7/8"-----	620	520	420	300	
3 1/2"-----	1"-----	750	625	525	375	
3 3/4"-----	1 1/8"-----	1,000	850	700	500	
4"-----	1 1/4"-----	1,200	1,025	850	600	
4 1/2"-----	1 1/2"-----	1,600	1,350	1,100	800	
5"-----	1 3/4"-----	2,100	1,800	1,500	1,050	
5 1/2"-----	2"-----	2,800	2,400	2,000	1,400	
6"-----	2 1/4"-----	4,000	3,400	2,800	2,000	
7 1/2"-----	2 3/4"-----	6,000	5,100	4,200	3,000	

27

RAMPS, RUNWAYS, PLATFORMS, AND SCAFFOLDS

SECTION 01—GENERAL

8305.01

A. Scaffolds shall be provided for all work that cannot be safely done from the ground or solid construction except such work as can be safely done from ladders. Scaffolds, platforms, runways, etc., shall be kept free of ice, snow, grease, mud and other such material; where slippery surfaces cannot be avoided, they shall be sanded to prevent slipping.

B. Lumber used in the construction of ramps, runways, platforms, and scaffolds shall be of good quality, reasonably straight grained, free of injurious ring shakes, checks, splits, cross gains, unsound knots, knots in groups, decay, and growth characteristics which materially decrease the strength of the material. The following table shall be used to determine the dimensions of scaffold planks:

Safe center loads for scaffold plank

[Select common eastern spruce, select common Norway pine and select structural eastern hemlock]

Span in feet	2 x 8 dressed to 1 $\frac{3}{4}$ x 7 $\frac{1}{2}$	2 x 10 dressed to 1 $\frac{3}{4}$ x 9 $\frac{1}{2}$	2 x 12 dressed to 1 $\frac{3}{4}$ x 11 $\frac{1}{2}$	3 x 8 dressed to 2 $\frac{3}{4}$ x 7 $\frac{1}{2}$	3 x 10 dressed to 2 $\frac{3}{4}$ x 9 $\frac{1}{2}$	3 x 12 dressed to 2 $\frac{3}{4}$ x 11 $\frac{1}{2}$
6	202	256	309	526	667	807
8	151	192	232	395	500	605
10	121	153	186	316	400	484
12	101	128	155	263	333	404
14		110	133	225	286	346
16			116	197	250	303

Above values are for planks supported at the ends, wide side of plank face up, and with loads concentrated at the center of the span.

For loads uniformly distributed on the wide surface throughout the length, the safe loads may be twice those given in the table.

Loads given are not and do not include the weight of the plank.

If select structural coast region Douglas fir, merchantable structural long leaf southern pine, or dense structural square edge and sound southern pine are used, above loads may be increased 45 percent.

SECTION 02—NAILS

8305.02

A. Nails used in the construction of ramps, runways, platforms, and scaffolds shall be driven full length. Design of construction shall be so that no nail will be subject to direct pull. No nail smaller than an 8d shall be used in the construction of scaffolds and sufficient nails must be driven in at each joint of the scaffold or falsework so that it will carry the loads designed to be imposed on them.

B. The following table will be used to determine the sizes of the nails to be used: -

Nails

[Safe working value for lateral resistance of one nail in Douglas fir or southern pine]

Size of nail.....	6D	8D	10D	12D	16D	20D
Value in pounds.....	53	62	83	98	130	175

Suggested rule: Value is approximately 8 times the pennyweight size.

SECTION 03—SCAFFOLD LOADS

8305.03

A. The erection, alteration and removal of all scaffolds, stagings, platforms, runways, and similar equipment shall be done under the direction and supervision of men experienced in scaffold work. No alteration shall be made which will impair the strength of the structure.

B. The principal members of scaffolds, runways, and similar equipment shall be substantially and securely braced.

C. Unless otherwise specified, planks used for platforms, scaffolds, stagings, runways, ramps, etc., shall be of uniform thickness and be laid close together. Such planks may be overlapped or butt jointed. In the former case they shall extend not less than 4 inches beyond the inside face of the bearings, unless securely fastened. Where planks are butt jointed and nailed to supports, an inch and one-half bearing for spans greater than 2 feet, and a three-quarter inch bearing for spans 2 feet or less, are permitted. Where planks project more than one-tenth of their length beyond the bearing they shall be securely fastened to prevent tipping or railed off over bearings.

D. Ramps and runways shall be not less than two 10-inch planks wide. Runways and ramps used for rolling equipment

except upon the ground, rough, temporary or finished floor, shall be not less than three 10-inch planks in width. Ramps and runways shall be inclined not more than 1 foot rise in 3 feet run and where the rise exceeds 1 foot in 5 feet run, nailed cleats shall be applied to the top surface. Runways and ramps shall be substantially supported and braced to prevent excessive spring or deflection and shall have planks thereof so placed and secured as to prevent loosening or displacement, with battens on the underside to prevent uneven deflection in the planks.

E. Discarded packing boxes, barrels, piles of loose lumber, or other makeshift material shall not be used as supports for scaffolds.

F. The platform and all supporting elements of scaffolds, runways, and similar equipment shall be designed to support a minimum uniform load per square foot of platform as follows:

Scaffold loads

Type of scaffold	Uniform load per square foot
Stone masons.....	75 lbs. Stone on scaffold.
Stone setters, 4 stories high.....	30 lbs. No stone on scaffold.
Stone setters, all stories.....	40 lbs. No stone on scaffold.
Bricklayers.....	50 lbs. Stocked.
Carpenter—Miscellaneous.....	20 lbs.
Painters and decorators.....	20 lbs.
Stucco.....	30 lbs. Hod stocked.
Lathers and plasterers.....	30 lbs.
Lathers—Precast work.....	Bay must be designed to carry weight of bay, casts, and men.

NOTE.—If concentrated load is used at any point in the span it shall not exceed one-half the uniformly distributed load.

G. Not more than one thickness of loose brick, tile, or similar material, placed in such a manner as to present its greatest surface (laid flat), shall be used under scaffolds, frames, horses or risers.

SECTION 04—POLE SCAFFOLDS

8305.04

A. The following schedules of designs and dimensions shall be used for all pole scaffolds. Materials of different sectional dimensions may be used, but they shall be of equal or greater strength than that given in schedules. Spacing may be increased if the material and the cross-bracing to be used are increased sufficiently to give strength and rigidity equal to that required by the following schedule:

Pole scaffolds not more than 25 feet in height

Types of pole scaffolds and material dimensions

	Stone masons	Brick layers	Lathers, plasterers, stucco	Carpenters	Painters, decorators
	75 lbs.	50 lbs.	30 lbs.	20 lbs.	20 lbs.
Poles.....	4" x 4"	2" x 6"	2" x 6"	2" x 4"	2" x 4"
Ledgers.....	2" x 8"	2" x 8"	1" x 6"	-----	-----
Stringers ¹	1" x 6"	1" x 6"	1" x 6"	1" x 4"	1" x 4"
Bearers.....	2" x 6"	2" x 6"	2" x 6"	1" x 8"	2" x 6"
Putlogs.....	4" x 4"	4" x 4"	-----	-----	-----
Putlogs on edge nailed.....	2" x 6"	2" x 6"	2" x 6"	-----	-----
Braces.....	1" x 6"	1" x 6"	1" x 6"	1" x 4"	1" x 4"
Spacing poles:					
1. Long.....	7'-0"	8'-0"	8'-0"	8'-0"	8'-0"
2. Cross.....	5'-0"	5'-0"	5'-0"	5'-0"	7'-0"
Spacing ledgers, vertical spacing.....	4'-6"	4'-6"	6'-3"	7'-0"	7'-0"
			Putlogs and bearers approx. middle of span		
Planking.....	2" x 10"	2" x 10"	1 3/4" x 12"	2" x 10"	2" x 10"
Toeboards.....	2" x 6"	2" x 6"	-----	1" x 6"	-----
Toeboards nailed in center.....	1" x 8"	1" x 8"	-----	-----	-----

¹ Members which do not carry putlog or bearer load are designated as stringers.

B. Scaffolds over 25 feet and up to 64 feet in height:

Stone masons' poles.....	4" x 6"
Bricklayers' poles.....	4" x 4"
Plasterers' poles.....	4" x 4"
Carpenters' and miscellaneous poles.....	2" x 6"
Painters' poles.....	2" x 6"

C. Members which do not carry putlog or bearer load are designated as stringers.

D. The minimum width of carpenters', painters', decorators', and miscellaneous platforms shall be two, 2- by 10-inch planks.

E. Platforms for masons and bricklayers shall not be less than 4 feet in width, unless space will not permit.

F. Guard rails, toe boards, side screens, and overhead protection shall be provided on the outside of all pole scaffolds as required.

G. Pole scaffolds for work heavier than stone masons' pole scaffolds shall have a factor of safety not less than four and

shall conform to the general requirements for masons' pole scaffolds.

H. The lower end of the poles or uprights shall rest upon a firm foundation and shall be secured against lateral displacement.

I. Spliced poles shall be squared at the butt joints, made continuous and uniformly strong throughout their lengths with securely nailed or bolted cleats.

J. There shall be not less than two cleats to each splice or joint and shall be of sound wood not less than 30 inches long, 1 inch thick and of the width of the poles, placed so as to overlap the abutting ends of each pole by not less than 15 inches and securely fastened to the poles at least on two sides.

K. Ledgers shall be not less than 1 inch thick and 8 inches wide, unless otherwise specified, extend over two consecutive pole spaces and shall overlap the poles not less than 4 inches. They shall be left in position to brace the poles as the platform is raised with the progress of the work.

L. Ledgers shall be level and their top edges at the same height as the bottom of the openings in the wall for putlogs.

M. Ledgers that carry heavily loaded platforms shall be reinforced by bearing blocks securely fastened to the poles.

N. Ledgers shall be securely nailed or bolted to each pole and where possible shall be nailed or bolted to the inside of the poles or uprights.

O. Where two ledgers overlap on the same pole they shall be securely fastened and where two ledgers meet at right angles one shall be fastened with its ends sawed flush with the pole, the other overlapping in the usual manner.

P. Putlogs shall be square or rectangular in cross section and shall project not less than 6 inches over the ledgers. There shall be not less than three putlogs under platform planks and so spaced as to safely carry the load imposed upon them.

Q. The ends of putlogs on single pole types, shall be built into the wall and shall not be notched nor cut down.

R. Putlogs shall project into the wall not less than 4 inches and where windows or other openings are used, shall be rigidly held in place.

S. Two successive lengths of planking shall not abut upon a single putlog. When laid end to end, two parallel putlogs

shall be provided not more than 8 inches apart so one putlog will support the end of one plank and the other putlog the abutting end of the other plank.

T. Where the platform planks overlap on a single putlog the lap of both the lower and upper planks shall be not less than 6 inches over the center of the putlog. Platform planks shall project over the putlog at the end of the scaffold not less than 6 inches beyond the face, but not more than 12 inches, unless securely fastened against slipping or tipping or railed off over bearings.

U. Bearers shall be attached to frame buildings by notching a piece of lumber no less than 2 by 4 inches by 12 inches long to the size of the bearer so it will bear evenly on the 2-inch surface. The plate or piece so prepared shall be nailed securely to the side of the building and the bearer nailed to the plate.

V. Where a scaffold turns a corner, not less than one bearer shall be laid and securely fastened diagonally across the corner, so that one end may rest upon each of the two ledgers that meet at the corner, or by a 2- by 6-inch timber nailed to the outside of the end poles to set as bearer. Poles shall be spaced at shorter intervals and platform planks laid so as to prevent a tipping hazard.

W. Pole Scaffolds shall be securely and adequately braced and fastened in such a manner as to prevent swinging away from the building. Diagonal bracing shall be provided to prevent the poles whether spliced or not, from moving parallel to the walls or from buckling in any direction.

SECTION 05—OUTRIGGER SCAFFOLDS

8305.05

A. Outrigger or thrustout members shall be constructed in compliance with the provisions for allowable loads and stresses tables; they shall conform to the general requirements for masons' pole scaffolds and shall not project more than 6 feet from the outer face of the structure. The strength of outriggers or thrustouts shall be not less than a 2- by 10-inch timber on edge.

B. Working platforms suspended from outriggers shall have suspension frames, the vertical members of which shall not be less in size than 2-inch by 6-inch timber, extending not less than 10 inches above the tops of outriggers and fastened to

the outriggers by shoulder blocks resting on the outriggers and fastened to the vertical members. Such blocks shall not be less in size than 2-inch by 6-inch by 8-inch timber. The bottom ends of vertical members shall extend not less than 10 inches below the bottom of bearers and shall be fitted with shoulder blocks the same as provided above, upon which the bearers shall be set. The bearer shall be not less in size than 2-inch by 6-inch timber. The suspended frames shall be securely and substantially braced to prevent excessive sway.

C. The platform shall consist of not less than three 2- by 10-inch planks.

D. Outriggers shall be securely supported, held, and fastened in place at their inner ends and in the openings through which they project by means of U-bolts, spikes, bolts, lashings, anchoring, or other equivalent means.

E. Thrustouts shall not be built into a wall and left with no other support, but shall project entirely through the wall or through windows and be solidly supported and substantially braced.

F. Where pyramiding or built-up scaffolding is done on an outrigger or where it is necessary to extend the outrigger more than 6 feet beyond the face of the structure, the beams shall be of steel or extra heavy timber and shall be substantially supported and securely fastened as required in the preceding paragraphs. In such cases the scaffold proper shall conform to the requirements for pole scaffolds.

G. Guard rails, toe boards, side screens, and overhead protection shall be provided as specified for pole scaffolds.

SECTION 06—HORSE OR FRAME SCAFFOLDS 8305.06

A. Scaffold horses and frames shall be constructed in conformity to the allowable loads and stresses tables, not to exceed 16 feet in height, and maintained in substantial condition. Nailing extension legs on horses to increase their height or extensions nailed on bearers to increase their width is substantial alteration.

B. Masons' horse scaffolds shall be not less than 4 feet wide. Platform boards shall be not less than 2 inches in thickness by 10 inches wide and shall overlap the frames or horses not less than 4 inches.

C. All horse or frame scaffolds shall be set level on substantial foundations. When built more than one tier high,

the horses shall be set in vertical lines, separated at each tier with a continuous 2-inch plank placed under the vertical members thereof with cleats nailed to planks to prevent the end horse slipping off supports and with all parts of the scaffold securely braced to give rigidity to and to prevent excessive swaying of such scaffolds.

D. Horses for stone masons' scaffolds shall be constructed as follows:

	<i>Dimensions</i>
Bearers-----	3'' x 4''
Legs-----	1¼'' x 4¼''
Braces-----	1¼'' x 6''
Half diagonal braces-----	1¼'' x 3''

E. The distance between horses shall be not more than 8 feet and shall not be built over three tiers or horses high having a maximum total height of 16 feet.

F. Distance between legs at bottom shall be not less than two-fifths nor more than three-fifths the height of the horse.

G. Squares or frames used to support masons' scaffold planks shall be securely fastened on both sides at the corners with not less than 1- by 4-inch braces and shall have braces on both sides running diagonally from the center of each side to the center of adjacent side. The frames shall have lateral diagonal bracing not less than 1 by 8 inches in size on both the front and rear members of scaffold.

	<i>Dimensions</i>
Bearers-----	2'' x 4''
Leg-----	2'' x 4''
Braces, at corners-----	1'' x 4''
Braces, diagonal from center frame-----	1'' x 8''

H. The distance between frames shall not be over 8 feet; and shall not be built more than three tiers or frames high unless properly anchored and equivalent strength and rigidity provided.

I. Hinged frames used as horses to support scaffold shall be constructed similar to square or frames with diagonal bracing. They shall be provided with substantial cables, chains or other suitable methods to prevent spreading at the bottom a distance more than two-fifths the height of the frame. They shall not be used more than three tiers high, placed one over another.

	<i>Dimensions</i>
Bearers (2) -----	1'' x 8''
Legs-----	1'' x 8''
Braces—Diagonal at bottom-----	1'' x 4''

J. The distance between frames used as horses will be not more than 6 feet.

K. Material of different sectional dimensions and a different type of construction may be used for horses and frames, provided they conform to the requirements for allowable loads and stresses.

L. Horse or frame scaffolds 10 feet or more in height shall be equipped with standard guard rails and toe boards.

M. Not more than one tier of horse or frame scaffold shall be placed upon another scaffold. When the working platform of such imposed scaffold is 10 feet or more in height such imposed scaffold shall be securely fastened, substantially braced and provided with standard guard rails.

SECTION 07—LADDER JACK SCAFFOLDS

8305.07

A. Ladder jack scaffolds shall be constructed with a factor of safety of not less than 2 and conform generally to the provisions and specifications for ladders and secured against slipping, tilting, or tipping.

B. Ladder rungs shall not be used to support more than one section of plank and not more than 2 employees shall be permitted to work upon such section of planking at the same time.

C. Lapped planks shall be supported by ladder jacks attached to both side rails of the ladder and not to the rungs.

D. No ladder jack shall be used in connection with the triple extension ladders.

E. Platform planks shall be not less than 2 by 10 inches in size, of select structural grade, overlap the outer bearing surface not less than 8 inches and shall have a span of not more than 12 feet.

SECTION 08—CARPENTERS' PORTABLE BRACKET SCAFFOLDS

8305.08

A. Carpenters' portable bracket scaffolds shall be constructed and erected in conformity with the unit stresses and allowable loads tables.

B. The minimum width of platforms on carpenters' bracket scaffolds shall be not less than two 10-inch planks.

C. All brackets shall be built to carry safely at the outermost edge a load of two times the total weight to be placed upon it,

but not less than 400 pounds. Where bolts are used for fastening brackets to the building they shall be not less than $\frac{3}{4}$ inch in diameter. The use of lean-to or jack scaffolds over 8 feet in height is prohibited.

D. Brackets shall be securely anchored to the studding and not to the sheeting and they shall be securely braced against spreading or turning. Brackets shall be spaced not more than 10 feet center to center.

E. Carpenters' bracket scaffolds, 10 feet or more above the ground or other level, shall be guarded with rails and toe boards in accordance with requirements for guard rails, toe boards, and screens.

SECTION 09—WINDOW JACK SCAFFOLDS

8305.09

A. Window jack scaffolds shall be used only for the purpose of working at the window through which the jack is placed. Window jacks shall not be used as the supporting elements for other scaffolds.

B. Not more than one person shall be permitted on a window jack scaffold at any one time.

SECTION 10—FOOT SCAFFOLDS

8305.10

A. Discarded packing boxes, barrels, empty nail kegs, piles of loose lumber, or other makeshift material shall not be used as supports for scaffolds.

B. Foot scaffolds shall not exceed 36 inches in height, measured from the level upon which the supports are placed.

C. When placed upon other scaffolds or platforms whose elevation is above the surrounding area, such scaffolds shall have a minimum width of one 10-inch plank and a maximum height of 18 inches measured from the supporting platform or scaffold and one tier only shall be permitted.

D. Foot scaffolds in excess of 18 inches in height shall have a minimum width of two 10-inch planks and shall be supported on horses.

E. The construction of such scaffolds shall conform to the allowable loads and stresses as given in tables under "Pole Scaffolds."

**SECTION 11—GUARD RAILS, TOE BOARDS, 8305.11
SCREENS.**

A. Guard rails shall be provided as follows unless otherwise specified:

1. On platforms, runways, ramps, scaffolds, and similar equipment which are 6 feet or more in height measured from the ground or supporting area, or that are over or adjacent to deep holes, excavations, mortar beds, railroad tracks, furnaces, fluids, vats, high tension electric wires, machinery, or similar sources of danger.

2. Around the unused sides of all openings in roofs, platforms, floors, or shafts.

3. Where spreaders are used in window frames which extend to within 24 inches or less of the floor or door frames, such spreaders shall be substantially secured in place.

4. Wall openings shall be protected by standard railings and toe boards or gates not less than 42 inches high extending to the bottom of the opening.

B. Guard rails shall be not less than 36 inches, nor more than 46 inches in height, measured from floors to the tops of rails, with supporting uprights spaced not more than 8 feet on centers, and both substantially constructed of 2-inch by 4-inch timber. Other spacing or other material or devices may be used provided the strength, protection, and practicability of the construction is equal to or greater than that above specified.

C. Intermediate rails shall be not less than 1-inch by 6-inch boards or equivalent material unless otherwise specified.

D. Toe boards not less than 4 inches, net, in height, constructed of wood or metal shall be around all floor and shaft openings where guard rails are required.

E. Side screens shall be provided on all pole scaffolds over 20 feet in height that are adjacent to passageways, or where workmen are employed within 10 feet of the base of the scaffold, and where material is piled on scaffolds adjacent to and higher than toe boards. Side screens shall be made of substantial expanded metal or wire netting larger than 2-inch mesh or other equivalent material securely fastened in place.

SECTION 12—ROOFING DEVICES

8305.12

A. Devices used in the construction of pitched roofs or construction on pitched roofs, shall be securely fastened in place. Shingling footlocks shall be not less in size than 2- by 4-inch timber secured in place by properly spaced tin strips or other material of equivalent strength not less than 4 inches wide.

B. Crawling boards, ladders, or chicken ladders, provided with hooks, bolts, or solidly fastened cleats on the under side at the upper end to catch over the ridge-pole or otherwise substantially secured, shall be provided as protection against slipping or falling. Cleats shall be provided on crawling boards securely fastened thereto, not less in size than 2 by 1 inches and shall project approximately $2\frac{1}{2}$ inches on each side of the board.

C. Double crawling boards shall be securely bolted together by a hinge bolt or otherwise substantially secured.

SECTION 13—TEMPORARY AND PERMANENT STAIRWAYS

8305.13

A. Temporary and permanent stairways used for construction purposes shall be fitted with substantial and securely fastened treads and tightly floored landings or gratings.

B. Handrails shall be provided on the open sides of stairways and stair landings, except where such stairways and landings are protected by studding or other permanent construction. Toe boards shall be installed around stairwells in addition to railings.

C. Handrails shall be not less than 30 inches in height measured vertically from the front edge of tread of stairway or 36 inches in height from the floor or landing; with supporting uprights spaced not more than 8 feet on centers and both substantially constructed of not less than 2 inches by 4 inches timber or other material and spacing of equal strength and practicability.

D. Provision shall be made to prevent the use of stairways not equipped as required in the preceding sections during construction operations.

SECTION 14—TEMPORARY FLOORS

8305.14

A. Working areas on various floor levels shall be provided with temporary flooring of sufficient strength to support a minimum uniform load of 25 pounds per square foot.

B. Floor joists shall be securely fastened and braced.

C. Floor boards or planks shall be placed close together upon joists and shall extend not less than 4 inches beyond the inside face of the bearing nor more than 1 foot beyond supports unless securely nailed.

D. Temporary working floor areas exposed to an elevation of 4 feet or more shall be provided with guard rails and toe boards as described under "Guard Rails, Toe Boards, and Screens."

SECTION 15—PAINTERS' SWINGING SCAFFOLDS 8305.15

A. All hooks, ropes, cables, and blocks supporting scaffolds shall have a minimum factor of safety of four (4).

B. Every time the scaffold is erected, it shall be tested by raising the platform about 1 foot from the ground, and loading it with at least four times the maximum weight that will be imposed upon it.

C. The stirrups or hangers shall be of a strength at least equal to steel $\frac{3}{4}$ inch in diameter, and shall be so formed that guard rails may easily be secured to them.

D. The distance between hangers shall not exceed 14 feet. Where scaffolds having side rails reinforced by steel rods are used, a span of 22 feet shall be permitted.

E. The hooks used to support the scaffold shall be of a strength at least equal to steel having a cross section $\frac{5}{8}$ inch by 2 inches.

F. Hooks, cornice irons, outriggers, or other devices for fastening to the building shall be securely fastened to a reliable object of support, and shall be frequently inspected. Hooks shall be tied so that they cannot slip.

G. The platform, planks, or ladders shall overlap the stirrup or hanger by at least 12 inches. A bar, strip, or other device shall be permanently attached to the platform outside of the hanger to prevent the platform from slipping off the hanger. Scaffold platforms shall have a minimum width of 27 inches and shall be provided with a guard rail.

H. Two or more swinging scaffolds shall not at any time be combined into one by bridging the distance between them with planks or similar connecting links.

I. Means shall be provided to prevent the scaffold from swinging away from the building.

J. Ropes shall be of manila at least $\frac{3}{4}$ inch in diameter, and shall possess a factor of safety of at least ten (10). Where supporting ropes are brought over sharp corners or subjected in any way to abrasion, they shall be protected at such points by chafing gear. Splicing anywhere throughout the length of ropes or cables is prohibited. Ropes shall be properly spliced into standard 6-inch blocks.

K. A deep hook shall be provided on the lower block to facilitate making safe scaffold hitch. Scaffold hitch shall always be made on hook, never on any building or object other than the scaffold.

L. Steel cable possessing a factor of safety of eight (8) may be used with mechanical hoisting devices.

M. All fiber ropes, steel cables, other hangers, and falls of the scaffolds shall be protected to a height of at least 6 feet above the platform with acid-resisting material, and the ropes or cables shall hang over the outside edge of the scaffold platform when exposed to operations involving use of acids or caustics. Acids and caustics shall not be stored in the same room with scaffold equipment.

N. Not more than two men shall be permitted on the scaffold at the same time.

O. All ropes, slings, and tackle shall be thoroughly and frequently inspected. When not in use, they shall be stored in a dry place.

P. When leaving a swinging scaffold, the men shall lash it securely to the building. Buckets or other loose objects shall be removed from such scaffold immediately upon the cessation of work by the men.

Q. The hauling part of falls on swinging scaffolds shall be held by a man on the ground until scaffold hitch has been made overhead.

SECTION 16—BOATSWAINS' CHAIRS

8305.16

A. Boatswains' chairs used for painting, cleaning, or other operations shall be constructed and erected with the greatest possible care.

B. Boatswains' chairs shall have a hardwood seat at least 10 by 18 inches in size.

C. Suspenders for boatswains' chairs shall be not less than $\frac{5}{8}$ inch diameter manila rope doubled. The ends shall be passed through holes bored in the seat and then spliced together.

D. When cutting torches or other open flames are used by a man in a boatswain's chair, the suspenders shall be not less than $\frac{1}{4}$ -inch steel cable.

E. Where single lines are used to support boatswains' chairs they shall be manila rope of not less than 1 inch diameter. Where block and falls are used, rope shall be $\frac{3}{4}$ inch spliced into 6-inch blocks.

F. The hauling part of line used to raise and lower chair shall always be within reach of the man using chair.

G. Safety belts shall be worn by men occupying boatswains' chairs, such belt being fastened to the supporting tackle and so arranged that the workman cannot slip out of the seat.

SECTION 17—SUSPENDED SCAFFOLDS

8305.17

A. None but scaffold machines approved by the Underwriters Laboratories shall be used in the erection of any scaffold. They shall not be used for any other purpose.

B. The moving parts of scaffold machines shall be frequently inspected and shall be exposed to view at all times so that possible defects may be readily detected. Such moving parts shall be so guarded as to protect workmen from coming into contact with same.

C. Outriggers shall be equal in strength to 6-inch steel I-beams and shall be securely anchored to the frame of the building by means of U-bolts and anchor plates tightened by the use of jam or lock nuts, or by other approved equally effective means. Outriggers shall extend at least 12 inches beyond the outside edge of scaffold platform.

D. I-beam outriggers shall be equipped with a stop bolt of adequate size to prevent the shackle from slipping over the outside end of the beam.

E. Cables on all suspended scaffolds shall possess factors of safety of at least eight (8). A metal tag shall be placed on all cables at a point readily accessible to inspection, showing the size and material of the cable, including the maximum safe load and date of renewal.

F. Particular care should be taken in the pouring of sockets, and the metal used shall be zinc. When thimbles and clamps are used, not less than three clips shall be used at each fastening.

G. Splicing anywhere throughout the length of the cable is prohibited. Where riding of the cable on the drum occurs, it shall be adjusted immediately by someone experienced in such work.

H. Putlogs shall be securely fastened to the scaffold fixtures and spaced not more than 8 feet apart.

I. Platform planks shall be laid so that their edges abut and fit tight. Planks shall be not less than 2 by 10 inches.

J. Platform planks shall overlap putlogs by at least 1 foot but not more than 2 feet at the ends of the scaffold.

K. All suspended scaffolds shall be tied in such a manner as to prevent the scaffold from swaying or swinging away from the building.

L. Where work is being performed overhead, an overhead protective covering shall be provided on all suspended scaffolds at a height not more than 9 feet above the working platform.

M. Guard rails and toe boards shall be provided as specified for pole scaffolds.

SECTION 18—NEEDLE BEAM SCAFFOLDS

8305.18

A. All needle beams shall be plainly marked so as to provide against being used for any other purpose.

B. Wood needle beams up to 12 feet in length shall be at least 4 by 6 inch spruce or other approved lumber of equal strength, and shall be free from knots or other imperfections. For longer spans or heavier loads, the cross section shall be proportionately increased.

C. All needle beams shall be at least 2 feet longer than the distance between the supports, and shall be one solid piece without splicing. Provision shall be made to prevent the supporting ropes from slipping over the ends of the beam.

D. Pipe needle beams shall be of one piece wrought iron or steel pipe free from rust or scale.

E. When the scaffold span is not more than 12 feet, the pipe shall be at least $3\frac{1}{2}$ inches in diameter. For longer spans or heavier loads the diameter of the pipe shall be proportionately increased.

F. Where the space between needle beams is 12 feet or less, the platform shall be composed of planks at least 10 inches wide and 2 inches thick. Where the span is over 12 feet, the cross section of the planks shall be increased in proportion.

G. Platforms in the interior of a building shall be not less than 2 feet 6 inches wide; on the outside not less than 3 feet 6 inches wide.

H. All planks shall be secured by suitable cleats or drop bolts to prevent them from slipping, tipping, or collapsing. Where the planks are to be used in a steeply inclined position, they shall be provided with cleats at least $1\frac{3}{4}$ by 2 inches in cross section, spaced not more than 8 inches apart.

I. The ropes shall be attached to the needle beams by a scaffold hitch or some other equally effective method. All ropes shall be so secured to the beams or girders as to prevent slipping or tipping of scaffold.

J. The rope shall be at least $1\frac{1}{4}$ inch in diameter, and shall be increased in proportion to the size of the load. The supporting rope shall not be attached to the needle beam, at a point less than 1 foot from the end of the beam.

LADDER SPECIFICATIONS

SECTION 01—GENERAL

8306.01

A. Construction ladders shall be provided and maintained in place during working hours until temporary or permanent stairways are ready for use.

B. Single rail ladders shall not be constructed for use except as provided for under "Roofing Devices."

C. Wood side rails shall be of thoroughly seasoned material free from shakes, cross grain, checks, and decay. Knots shall not exceed $\frac{1}{2}$ inch in diameter and shall not be nearer than $\frac{1}{2}$ inch to the edge of the rail or 3 inches of the rung.

D. Wood rungs shall be of thoroughly seasoned material free from knots, shakes, cross grain, large checks, or decay. They shall be of white oak, ash, or material equivalent thereto in strength and wear.

E. Wood rungs shall be inserted in holes in the side rails and in all cases securely fastened, with a uniform spacing between rungs, not to exceed 12 inches on centers.

F. Ladders with weakened, broken, or missing treads, rungs, or cleats or broken side rails shall not be used, and ladders which have developed defects shall be withdrawn from service. Cleats shall not be used to repair rung ladders.

G. Ladders when in place shall have a substantial bearing for all rails at the bottom and when inclined shall have a substantial support at or near the top.

H. Ladders placed where there is danger of slipping shall be secured by the use of cleats, metal points, safety shoes, lashing, or other effective means. Painted ladders will not be permitted. However, linseed oil or clear varnish may be used.

I. All ladders with spreading bases such as step and trestle ladders shall be equipped with rigid spreaders or other means to prevent their premature opening or closing.

J. Fixed ladder landings shall be equipped with standard guard rails and toe boards. Such platform shall be not less than 24 inches in width.

K. Rails of fixed ladders to landings shall extend a distance of at least 36 inches above the landing. The rungs may be omitted above the landing. Landing shall be provided where an employee must step a greater distance than 14 inches from ladder to roof, tank, etc.

L. The landing distance shall not be greater than the rung spacing of the ladder.

M. Portable ladders shall not be used with a pitch such that the horizontal distance from the wall to the foot of the ladder shall exceed one-fourth of the unsupported length of the ladder unless it is securely braced to prevent sagging.

N. Ladders not specifically mentioned herein shall be of sufficient strength to resist double the strain of the heaviest load that will be placed upon it in use.

O. Single ladders not constructed to be used as sectional ladders shall not be spliced together to form a longer ladder unless such splicing together shall provide and maintain the strength and rigidity required for ladder construction.

P. Ladders on which workers are employed when placed in passageways, doorways, driveways, or public thoroughfares shall be guarded by barricades (guard rails). Doors which open adjacent to where such work is being done on ladders shall be securely closed or fastened open while work is in progress. Working from ladders is not an acceptable practice and should not be countenanced except for minor operations. No one shall ascend or descend a ladder except by facing the rungs.

SECTION 02—SINGLE RUNG LADDERS

8306.02

A. Side rails and rungs shall have a minimum dressed cross section of the following dimensions:

Length	Rail sections	Rungs
Up to and including 16 feet.....	1½" x 2½".....	1½"
Over 16 feet and up to and including 20 feet.....	1¾" x 2¾".....	1¾"
Over 20 feet and up to and including 24 feet.....	1¾" x 2¾".....	1¾"

B. Ladders with parallel side rails shall have a minimum inside width between rails of 12 inches.

C. Ladders with spread rails shall have a minimum inside width at top rung of 12 inches and at each succeeding rung ¼ inch wider.

D. Rungs shall not exceed 30 inches in length.

E. Tenons shall be ⅞ inch in diameter.

F. Masons' single ladder up to 22 feet in length shall have side rail cross section of $1\frac{3}{8}$ by 4 inches and spaced not more than 10 inches on centers.

G. High-grade manufactured ladders with curved side rails will be permitted.

SECTION 03—SINGLE CLEAT LADDERS

8306.03

A.

Length	Minimum inside width	Maximum inside width	Cross section of rails	Cross section of cleats
Up to 12'	20"	24"	2" x 4"	1" x 3"
More than 12' and up to 16'	20"	24"	2" x 4"	1" x 3"
More than 16' and up to 20'	20"	24"	2" x 6"	1" x 4"
More than 20' and up to 24'	20"	24"	2" x 6"	1" x 4"

The lumber dimensions given in the above table are trade sizes.

B. Fixed ladders shall follow dimensions given for single cleat ladders and may exceed 24 feet in height provided they are securely fixed or braced at intervals of not more than 15 feet.

SECTION 04—EXTENSION LADDERS

8306.04

A.

Length	Cross section of rails	Diameter rungs
Up to and including 32'	$1\frac{5}{8}$ " x $2\frac{3}{4}$ "	$1\frac{1}{8}$ "
More than 32' and up to 38'	$1\frac{5}{8}$ " x 3"	$1\frac{1}{8}$ "
More than 38' and up to 44'	$1\frac{3}{8}$ " x $3\frac{1}{4}$ "	$1\frac{1}{8}$ "

B. Each ladder shall be equipped with two automatic locks. Locks shall be of such construction as to make the extension ladder equal in strength to a ladder constructed of continuous side rails.

C. All parts of the lock shall be of malleable iron or other equivalent material.

D. All other iron parts of the ladder shall be of malleable or wrought iron or equivalent material.

E. Where pulleys are used the ladder shall be equipped with a galvanized malleable or wrought iron shackle and pulley.

F. The lumber dimensions given herein are minimum dressed.

G. Tenons shall be not less than $\frac{7}{8}$ inch in diameter.

H. Masons' extension ladder shall be limited to two sections and to 44 feet in length, shall have side rails $1\frac{3}{8}$ by 4 inches. Width of bottom section shall be not more than 20 inches; rungs not less than $1\frac{1}{4}$ inches in diameter and tenon 1 inch in diameter.

SECTION 05—STEP LADDERS

8306.05

A. Step ladders shall be limited to 20 feet in height. Higher step ladders may be used providing the sizes of construction members and bracing are increased so as to furnish the same factor of safety as provided herein.

B. Side rails dimensions up to and including 10 feet shall be $2\frac{5}{32}$ by $2\frac{5}{8}$ inches. Back legs, $2\frac{5}{32}$ by $1\frac{5}{8}$ inches.

C. Side rail dimensions for step ladders more than 10 feet and up to 20 feet shall be $2\frac{5}{32}$ by $3\frac{1}{4}$ inches. Back legs, $2\frac{5}{32}$ by $2\frac{1}{4}$ inches.

D. Step dimensions shall be $2\frac{5}{32}$ by $3\frac{5}{8}$ inches, set into each side rail $\frac{1}{8}$ inch and supported by a $\frac{1}{4}$ -inch steel rod.

E. Bracing strips in backs shall be metal bound at ends. Material used in spreaders shall be equal in strength to $\frac{1}{8}$ -inch by $\frac{1}{2}$ -inch steel.

F. The lumber dimensions given herein are minimum dressed.

SECTION 06—SECTIONAL LADDERS

8306.06

A. The minimum dressed cross-section and distance between side rails of sectional ladders shall be as follows:

Sections	Side rails—cross section		
	Thickness (inches)	Depth (inches)	Distance (inches)
Up to and including 4 sections.....	$1\frac{1}{8}$	$2\frac{3}{4}$	13
Over 4 sections up to and including 6.....	$1\frac{3}{8}$	$3\frac{3}{8}$	20
Over 6 sections up to and including 10.....	$1\frac{7}{8}$	$3\frac{3}{4}$	24

B. If the length of sections exceeds 6 feet 4 inches the side rail cross sections shall be correspondingly increased.

C. Rungs shall be $1\frac{1}{8}$ inches in diameter with $\frac{7}{8}$ -inch tenon.

D. The connection joint shall be not less than 1 foot. The grooved ends of the sections shall be reinforced with a metal plate not less than No. 18 U. S. Standard gage properly secured thereto and riveted above the groove extending through the depth of the rail or other equivalent fastening.

SECTION 07—TRESTLE LADDERS

8306.07

A. Sides for ladders up to 10 feet in length shall be $1\frac{5}{16}$ inches by $2\frac{3}{4}$ inches, minimum dressed. Rungs $1\frac{1}{8}$ inches in diameter shall be of oak, ash, or other wood of equal strength.

B. Longer ladders shall have side rails of proportionately larger dimensions.

C. Lumber shall be No. 1 clear spruce or other wood of equal strength.

D. Metal parts shall be malleable or wrought iron or metal of equivalent strength.

E. Rungs shall be rabbeted through the side and securely fastened thereto.

SECTION 08—EXTENSION TRESTLE LADDERS

8306.08

A. Sides of base for extension trestle ladders shall not be less than $1\frac{3}{8}$ inches by $2\frac{3}{4}$ inches, minimum dressed. Base section shall not exceed 16 feet in length.

B. Rungs of base and extension shall be $1\frac{3}{8}$ inches in diameter, of oak, ash, or other wood of equal strength, rabbeted through side rails and securely fastened thereto.

C. Sides of the extension section shall not be less than $1\frac{3}{8}$ inches by $2\frac{3}{8}$ inches and shall not exceed 16 feet in length.

D. Lumber for extension trestle ladders shall be No. 1 clear spruce or other wood of equal strength.

E. Metal parts shall be malleable or wrought iron or other metal of equivalent strength.

F. The locking device for securing the extension section to the base shall be of design as efficient as that specified for extension ladders.

PAINING

SECTION 01—STORAGE OF PAINTS

8307.01

A. Packages containing paints, varnishes, lacquers, thinners, or other volatile painting materials shall be kept tightly closed when not in actual use, and shall be stored in well ventilated places where they will not be exposed to excessive heat, smoke, sparks, flame, or direct rays of the sun.

SECTION 02—SPRAY PAINTING

8307.02

A. Spray painting in enclosed places with materials containing lead, benzol or any ingredient injurious to health shall be segregated from other employees by a temporary partition of canvas or other suitable material. If lights, switches and live electric wiring are necessary they shall be of the explosion proof type.

B. Spray machine operators shall be required to wear a garment which fits close at the ankles, neck, and wrists and shall also be required to wear gloves, goggles, and approved type respirators while engaged in spraying materials other than water paints while in an enclosure.

C. No smoking or open fire of any kind shall be permitted in rooms where spray guns are in operation.

ELECTRICAL WIRE AND APPARATUS**SECTION 01—GENERAL**

8308.01

A. Electric wiring in temporary or permanent use shall be installed and maintained, by competent and qualified workmen, so as to effectively protect all persons against injury therefrom.

B. Substantial insulation, grounds, or other protection shall be provided during construction operations to protect employees from injuries resulting from temporary or permanent electric wiring or apparatus.

C. Extension cords to lights and electrically operated tools or devices, together with their connections and fittings shall be insulated and maintained in a safe condition. Wires carrying electrical current shall not be run on the ground unless effectively insulated.

D. Wiring equipment such as fastenings, connections, etc., where accessible to workmen shall be nonconductive and/or where conductive equipment is used the same shall be guarded so as to protect workmen against the injury.

E. No work shall be done on any wiring or equipment carrying 600 volts or over until the portion being worked upon is protected on both sides by grounds, blocks, bypasses, hold-off systems or by other effective means.

F. All work on electric wiring and equipment carrying 600 volts or more, shall be performed by men competent and qualified in high voltage installations.

G. Suitable insulating mats or platforms of substantial construction and providing good footing shall be so placed on floors and, if necessary, on the frames of the machines having exposed live parts of more than 150 volts to a ground, that the operator or persons in the vicinity cannot readily touch such parts unless standing on the mats, platforms, or insulating floors.

H. A notice shall be posted in the cab of every derrick, crane, dragline, etc., prohibiting the operator from bringing the boom or crane within 10 feet of high voltage wires.

I. Overloading of electric circuits is prohibited.

J. All circuits shall be fused or have circuit breakers adjusted for the designated safe load.

K. The use of slugs or jumpers on circuit breaking devices is prohibited.

BLASTING**SECTION 01—GENERAL**

8309.01

A. The transportation, handling, storage and use of dynamite and other explosives shall be directed and supervised by a person of proven experience and ability in blasting operations. These operations shall be in accordance with the following requirements:

1. All blasts must be fired with an electric blasting machine.
2. When detonating fuse is used, it shall be fired by the use of an electric blasting cap.

B. Blasting machines must be known to be in good condition and of sufficient capacity to fire all charges. For blasting machines the following performance rating shall apply:

1. The machines shall fire without failure at least five times in succession, two electric blasting caps in series, through resistance as follows:

75 Ohms for 10 cap machines.

144 Ohms for 30 cap machines.

208 Ohms for 50 cap machines.

320 Ohms for 100 cap machines.

C. Rubber covered or other adequately insulated copper wires in good condition shall be used for firing lines and shall have solid cores. Sufficient firing line shall be provided to permit the blaster and other workers to be located at a safe distance from the blast. Single conductor lead lines shall be used.

SECTION 02—TRANSPORTATION OF EXPLOSIVES 8309.02

A. Trucks used for the transportation of explosives must not be loaded beyond rated capacity and the boxes of explosives must be so secured that they cannot drop off the truck. In all open body types of vehicles the explosives must be covered with a fire resistant tarpaulin.

B. All trucks used for the transportation of explosives shall be marked or placarded on both sides and ends with the word "Explosives" in letters not less than 3 inches high or shall conspicuously display a red flag not less than 24 inches square,

marked with the word "Danger" in white letters not less than 6 inches high.

C. Electric blasting caps shall not be transported in the same vehicle with other explosives.

D. All trucks shall be in the charge of and operated by a person who is physically fit, careful, reliable, able to read and write the English language and not addicted to the use of intoxicants or narcotics. No person under the influence of intoxicants or narcotics will be permitted to transport, handle, or otherwise use explosives.

E. No metal, metal tools, carbides, oils, matches, firearms, electric storage batteries, inflammable substances, acids, oxidizing or corrosive compounds shall be carried in the bed or body of any motortruck and/or vehicle transporting explosives.

F. Trucks to be used in the transportation of explosives must be clean and in good repair. When steel or part-steel bodies are used, canvas or other relatively nonflammable cushioning materials must be employed to separate the explosives from the metal.

G. Trucks shall be equipped with not less than two fire extinguishers, placed at convenient points, filled and ready for immediate use, and of a make approved by the National Board of Fire Underwriters.

H. A truck containing explosives shall never be taken into a garage or repair shop or parked in congested areas or stored over night, or at any other time, in a public garage or similar building.

I. All trucks shall be checked before transporting explosives and all electric wiring completely protected and securely fastened to prevent short circuiting.

J. Trucks transporting explosives shall be operated with extreme care and shall not be driven at a speed greater than 25 miles per hour. Full stops shall be made at approaches to all railroad crossings and main highways and the truck must not proceed until it is known that the way is clear.

K. Explosives shall not be transported in any form of trailer, nor shall any trailer be attached to a motortruck or vehicle hauling explosives.

L. No person other than the authorized driver and helper shall be permitted to ride on trucks transporting explosives or detonators.

M. Explosives shall not be transported during hours of darkness except in extreme emergency and only when the written approval of the area engineer has been secured.

N. The gasoline tank of a motortruck shall not be filled while explosives are on the motortruck except in emergency and then only when the engine of the motortruck is stopped.

O. Explosives unloaded from trucks shall be piled at sufficient distance from exhaust to prevent danger of sparks igniting the explosives.

P. Persons employed in the transportation, handling, or other use of explosives shall not carry on their person or in the truck, matches, firearms, ammunition, or other flame producing devices.

SECTION 03—HANDLING OF EXPLOSIVES

8309.03

A. Containers of explosives shall be opened only by means of wooden wedges and wooden mallets. The dropping of loaded containers for the purpose of opening the same is prohibited.

B. Dynamite cartridges shall only be removed from containers as they are needed for immediate use and carried to the blasting area in nonmetallic containers.

C. Explosives and detonators shall be taken to the blasting area in separate nonmetallic containers, except that primers prepared at a central priming station may be carried in a non-metallic container.

D. After loading of a blast is completed, all excess explosives and detonators shall be returned at once to the storage magazine, observing the same rules as when being conveyed to the blasting area.

E. All empty dynamite boxes showing stains of any kind shall be destroyed by burning out of doors at a safe distance from magazine and other structures.

SECTION 04—STORAGE OF EXPLOSIVES

8309.04

A. Separate magazines shall be provided for storage of explosives and detonators. Such magazines shall be bullet proof, fire resistant and weather proof and of an approved type and shall be adequately ventilated. The minimum distance between magazines storing detonators and explosives shall be 100 feet unbarricaded or 50 feet barricaded.

B. The area around the magazine for a distance of 25 feet shall be kept clear of vegetation and all combustible matter.

C. The magazines shall not be unlocked except for inspection and the storage and removal of explosives; and the key shall be in the charge of a reliable and competent person who shall be in charge of explosives and the magazines.

D. Shoes with nails or metal plates which are likely to cause friction sparks shall not be worn in magazines.

E. Magazines in which explosives are stored shall not be used for any other purpose. No metal tools of any description shall be kept in magazines.

F. Explosives shall be arranged in the magazine so that oldest stock is used first.

G. Repairs to inside of magazines shall not be made without first removing all explosives to a safe distance and providing them with ample protection.

H. Explosives shall be stored only in original containers.

I. Explosives shall be stored with top side up.

J. Magazines shall be kept dry and clean, and the area around the magazine posted with appropriate "Caution" or "Danger" signs.

K. Magazine floors shall continually be kept clean.

L. Explosives containers shall be opened, packed or repacked only at a distance of at least 50 feet from any magazine.

M. No smoking, matches, firearms, open flames, or any flame producing device, shall be permitted within 100 feet of any magazine.

N. Magazine floors that become stained with nitro-glycerin shall be scrubbed with a stiff broom or brush using a freshly made solution composed of $\frac{1}{2}$ gallon of water, $\frac{1}{2}$ gallon of wood alcohol and 2 pounds of sulphide of sodium. Plenty of the liquid should be used so as to thoroughly decompose the nitro-glycerin.

O. Detonators shall not be taken into a magazine containing other explosives.

P. Opened boxes of explosives shall not be left in a magazine.

Q. All magazines in which explosives are had, kept, or stored shall be located at the distance from buildings, railroads, and highways in conformance with the following table:

American table of distances

Quantity that may be had, kept or stored				Distance (feet) from nearest—		
Electric blasting caps		Dynamite				
Number over	Number not over	Pounds over	Pounds not over	Build- ing	Rail- way	High- way
1, 000	5, 000	-----	-----	30	20	10
5, 000	10, 000	-----	-----	60	40	20
10, 000	20, 000	-----	-----	120	70	35
20, 000	25, 000	-----	50	145	90	45
25, 000	50, 000	50	100	240	140	70
50, 000	100, 000	100	200	360	220	110
100, 000	150, 000	200	300	520	310	150
150, 000	200, 000	300	400	640	380	190
200, 000	250, 000	400	500	720	430	220
250, 000	300, 000	500	600	800	480	240
300, 000	350, 000	600	700	860	520	260
350, 000	400, 000	700	800	920	550	280
400, 000	450, 000	800	900	980	590	300
450, 000	500, 000	900	1, 000	1, 020	610	310
500, 000	750, 000	1, 000	1, 500	1, 060	640	320
750, 000	1, 000, 000	1, 500	2, 000	1, 200	720	360
1, 000, 000	1, 500, 000	2, 000	3, 000	1, 300	780	390
1, 500, 000	2, 000, 000	3, 000	4, 000	1, 420	850	420
2, 000, 000	2, 500, 000	4, 000	5, 000	1, 500	900	450
2, 500, 000	3, 000, 000	5, 000	6, 000	1, 560	940	470
3, 000, 000	3, 500, 000	6, 000	7, 000	1, 610	970	490
3, 500, 000	4, 000, 000	7, 000	8, 000	1, 660	1, 000	500
4, 000, 000	4, 500, 000	8, 000	9, 000	1, 700	1, 020	510
4, 500, 000	5, 000, 000	9, 000	10, 000	1, 740	1, 040	520
5, 000, 000	7, 500, 000	10, 000	15, 000	1, 780	1, 070	530

NOTE.—For larger quantities see the complete American Table of Distance.

A 50 percent reduction in the above distances may be applied in connection with magazines that are screened from buildings, railroads, highways, or other magazines either by natural features of the ground or by an efficient artificial barricade of such height that any straight line drawn from the top of any sidewall of the magazine to any part of the building to be protected will pass through such intervening natural or efficient artificial barricade, and any straight line drawn from the top of any sidewall of the magazine, to any point 12 feet above the center of the railroad or highway to be protected, will pass through such intervening natural or efficient artificial barricade.

R. Magazines in which more than 50 pounds of explosives are stored shall be detached from other structures, and magazines where more than 5,000 pounds of explosives are stored shall be located at least 200 feet from any other magazine, except blast-

ing cap magazines. Magazines where quantities of explosives in excess of 25,000 pounds are kept and stored shall have an increase over 200 feet of $2\frac{3}{8}$ feet for each 1,000 pounds of explosives in excess of 25,000 pounds stored therein. These distances between magazines may be disregarded where the total quantity stored in the several magazines complies with the American Table of Distance as regards proximity to inhabited buildings, railways, and highways—except that in all cases, the quantity of explosives contained in blasting-cap magazines shall govern in regard to spacing said cap magazines from magazines containing other explosives, but under no circumstances shall a magazine containing blasting caps be within a less distance than 100 feet not barricaded, or 50 feet barricaded from any magazine other than cap magazine.

SECTION 05—DRILLING

8309.05

A. All drill holes shall be of greater diameter than the diameter of cartridges of explosives used. Loading and drilling shall not be carried out at the same time in the same area.

B. Drilling shall not be started until all remaining butts of old holes are examined for unexploded charges. Never insert a drill, pick, or bar in such holes even if examination fails to disclose explosives.

C. Drilling shall not be resumed after blasts have been fired until a thorough examination has been made to make sure that there are no unexploded charges remaining.

SECTION 06—LOADING

8309.06

A. In loading small diameter bore holes, tamping shall be done with a wooden stick having no metal parts. Primed cartridges shall be seated by even steady pressure only.

B. All loaded holes or charges shall be checked and definitely located before firing.

C. When holes are sprung, leave ample time between springing shots for the hole to cool, and also between the last springing shot and the loading of the main charge.

D. No more cartridges shall be primed than are required for a single round of blasting. Detonators shall only be inserted in a hole in the end of a cartridge prepared especially for that purpose. Holes shall be made with a sharpened wooden stick.

E. All charges shall be covered with blasting mats before firing, where blasting is done in the vicinity of structures likely to be injured by flying rock.

SECTION 07—WIRING

8309.07

A. Each electric blasting cap shall be tested with an approved galvanometer before and after tamping a hole.

B. All caps in a blast shall have copper wire and shall be of the same manufacture.

C. After testing the leg wires of electric blasting caps, they shall be short-circuited by twisting the bare ends together and shall remain so twisted until ready to be connected into the circuit preparatory to connecting to the firing line.

D. All electric blasting caps shall be wired in series and the firing line shall not be smaller than No. 14 B and S gage copper wire.

E. The number of electric blasting caps fired in one series shall not exceed the rated capacity of the blasting machine.

F. The circuit including all caps should be tested with an approved galvanometer before being connected to firing line.

G. The complete circuit, lead wires and firing line, should be checked with an approved galvanometer at the terminals to be hooked on to blasting machine.

H. No firing line shall be connected to a blasting machine until just before the shot is to be fired.

I. Cartridges shall not be primed nor holes loaded during approach of a thunderstorm or while it is in progress. If a charge has been primed or holes loaded, every person shall be ordered to a safe distance until the storm is over.

SECTION 08—FIRING

8309.08

A. Prior to the firing of a shot, all persons in the blasting area shall be warned of the blast and ordered to a safe distance from the area. Blast shall not be fired until it is *absolutely certain that every person* has retreated to a safe distance and that no one remains in a dangerous location.

SECTION 09—INSPECTION AFTER BLASTING

8309.09

A. Immediately after blast has been fired, the firing line shall be disconnected from the blasting machine and carried back at

least half the distance from the blasting machine to the area of the blast.

B. The firing line shall be left in this position until all inspection and checking work has been completed.

C. After the blast has been fired, a minute inspection shall be made to determine if all charges have been exploded before any person is allowed to return to the area of the blast.

D. All wires shall be carefully traced and search made for unexploded cartridges.

SECTION 10—MISFIRES

8309.10

A. If broken wires, faulty connections, or short circuits are determined as the cause of a misfire, the proper repairs shall be made, the firing line reconnected, and the charge fired. This shall be done, however, only after a careful inspection has been made of burdens remaining in such holes and no hole shall be so refired when the burden has been dangerously weakened by other shots.

B. Misfired charges tamped with solid material shall be blasted out by the process of detonation by concussion. In using this method a new hole shall be drilled and fired at a point no nearer than two feet from the misfired charge. In following this procedure a careful search shall be made for unexploded material in the debris of the second charge.

INFLAMMABLES**SECTION 01—GENERAL**

8313.01

A. All storage, handling or use of inflammables shall be under the supervision of qualified persons. No one shall be permitted to handle or use inflammables until he has been instructed in the safe handling and use of same.

B. A monthly inspection shall be made of all systems and equipment used for the storage, handling or processing of inflammables.

C. All sources of ignition shall be prohibited in areas where inflammables are stored, handled and processed. Suitable warning and "No Smoking" signs shall be posted in all such areas.

D. Rubbish, brush, long grass, or other combustible material shall be continually removed from areas where inflammables are stored, handled or processed.

E. All spills of inflammable liquids shall be cleaned up immediately.

F. All inflammables, including intrastate shipments, shall be in containers approved for shipment of such materials by, and tagged or labeled in accordance with regulations of I. C. C.

G. All tanks, containers and pumping equipment, portable or stationary, used for the storage or handling of inflammables shall meet the requirements of the National Board of Fire Underwriters.

H. Electrical lighting shall be the only means used for illumination in areas where inflammable liquids, vapors, fumes, dusts or gases are present. All electrical equipment and installations shall be in accordance with provisions of the National Electrical Safety Code for hazardous locations. Globes of the vapor proof type shall not be removed or lamps replaced until it is certain that the circuit is dead.

I. Flashlights and electric lanterns used in connection with the handling of inflammables shall be the type approved by the Underwriters' Laboratories.

J. Heating systems in buildings where inflammables are stored or processed shall be installed in accordance with regulations of the National Board of Fire Underwriters.

K. All buildings, rooms and compartments where inflammables are present shall be properly ventilated. Where mechanical ventilation or exhaust systems are necessary, they shall be installed in accordance with regulations for installation of blower and exhaust systems by the National Board of Fire Underwriters.

L. Approved type fire extinguishers shall be provided at all locations where inflammables are stored, processed or used.

M. No person shall enter a storage tank, tank car or other vessel which has contained inflammables until such vessel has been properly purged and ventilated. After purging and venting a test shall be made for gas. If the vessel is not gas free, purging and venting shall be repeated.

N. All persons entering storage tanks, tank cars, or other vessels which have contained inflammable fluids or gases shall be provided with necessary protective clothing, approved air fed masks, safety belts, and life lines. An attendant shall be stationed at the entrance to such tank or vessel.

O. No welding, cutting, riveting, or other hot work and no mechanical work shall be performed on a storage tank, tank car or other vessel which has contained inflammables until such vessel has been properly purged and ventilated. After purging and venting a test shall be made for gas. If the vessel is not gas free, purging and venting shall be repeated. Tanks or other containers brought to the shop for repair shall be purged and vented outside of buildings and well away from open flames and other sources of ignition.

P. Welding, riveting, or other hot work on tanks or containers which have contained inflammable liquids or gases shall be performed only by men experienced in such work.

Q. All tools used in hazardous atmospheres shall be of the non-sparking variety.

R. Woolen or asbestos fire blankets shall be provided and kept in conspicuous and easily accessible locations where inflammables are stored, handled and used.

SECTION 02—STORAGE

8313.02

A. Storage of inflammable liquids shall be in accordance with the regulations of the National Board of Fire Underwriters.

B. Storage tanks and systems shall be electrically bonded and grounded in an approved manner.

C. All storage tanks shall be equipped with proper relief vents. Tank vents shall not be located close to open flames, stacks, heating apparatus or any other source of ignition. Vent screens shall not be painted. In freezing weather all vacuum and pressure reliefs shall be inspected daily.

D. Water draw off valves shall be insulated to prevent freezing.

E. All storage tanks above ground shall be diked, curbed, or other suitable means provided to prevent the spread of liquids to other property in case of a rupture in tank or piping. Such dike or curbed area shall have a capacity equal in volume to that of the tank.

F. Outlets from storage tanks above ground shall be equipped with quick closing valves.

G. Inside storage of large quantities of flammable liquids or gases in drums or other containers shall be in a separate fire resistant building located at least 50 feet from adjoining buildings or structures.

H. Entrances to storage or process buildings shall be kept under lock and key. Only authorized persons shall be permitted to enter such buildings.

I. A ventilated metal cabinet shall be provided for the storage of more than a total of 10 gallons of oils, varnishes, lacquers or other inflammable liquids in buildings used for other than storage or processing, -Not more than a total of 50 gallons shall be stored in any one cabinet. No individual container shall exceed five gallons capacity.

SECTION 03—HANDLING AND USE

8313.03

A. All dispensing of inflammable fluids shall be by approved pumping arrangement from underground tanks or tank trucks. This rule applies to containers of over 55-gallon capacity. Use of pumping arrangement is recommended in all cases.

B. The handling of inflammable fluids in open containers is prohibited.

C. Tank cars or trucks shall be spotted accurately, and not loaded or unloaded until brakes have been set and wheels chocked.

D. Blue flag warning signs shall be clamped to the rails to warn train crews when tank cars are connected.

E. Tank cars or trucks shall never be left unattended while being loaded or unloaded.

F. All tank cars and trucks shall be properly bonded and grounded while being loaded or unloaded. Bonding and grounding connections shall be made before dome covers are removed on cars and trucks and shall not be disconnected until such covers have been replaced. Internal vapor pressure shall be relieved before dome covers are opened.

G. All processing and mixing of inflammable liquids shall be in separate fire resistant building except that in buildings of type A fire resistant construction such operations shall be permitted in separate rooms cut off from the rest of the building by 8-inch concrete or brick walls. Approved type fire doors shall be provided on such rooms. Entrances to all processing or mixing rooms shall be provided with a noncombustible sill raised 6 inches.

H. Floors in all process and mixing rooms shall be fire resistant and drainage provided to a safe location.

I. Not more than 1 day's supply of inflammable fluids shall be kept in any processing or mixing room. If 1 day's requirements are less than 55 gallons, not more than 1 drum shall be permitted.

J. Accumulations of flammable materials on floors, walls, etc., shall not be permitted.

K. Bungs, caps, or stoppers shall not be left out of drums, barrels, or other inflammable liquid containers. This rule also applies to empty containers.

L. All tanks, hoses, and containers shall be kept in metallic contact while inflammable liquids are being poured.

MACHINERY AND MECHANIZED EQUIPMENT

SECTION 01—GENERAL REQUIREMENTS

8316.01

A. Inspection.

1. Machinery and mechanized equipment, hereinafter called equipment, shall not be placed in operation until it has been inspected by a qualified person and found to be in safe operating condition.

2. A regularly weekly inspection shall be made of all equipment.

3. Defective equipment shall be removed from service, repaired and reinspected before being again placed in service.

4. Current records of all inspections shall be kept on file and be available for review by representatives of the Safety Section.

B. Guarding, Safety Devices, Ladders, Platforms, Etc.

1. All belts, gears, shafts, clutches, drums, flywheels, chains, and other reciprocating or rotating parts of equipment shall be guarded.

2. Platforms, footwalks, steps, ladders, hand holds, guard rails, and toe boards shall be provided on all equipment where necessary.

3. Means shall be provided to prevent the starting of equipment by unauthorized persons.

4. A suitable operating floor or platform of nonslip material shall be provided for all equipment operators.

5. No guard safety appliance or device shall be removed or made ineffective except for the purpose of immediately making repairs or adjustments and then only after the power has been shut off. Such guards and devices shall be replaced immediately after completion of repairs and adjustments.

6. Operators of equipment shall have suitable protection against the elements, falling objects, swinging loads, and similar hazards.

7. All windows in shields, cabs, or inclosures on equipment shall be of safety glass.

8. A warning device shall be provided on all equipment where there is danger to workmen in moving the equipment or from swinging loads, buckets, booms, etc.

9. All current carrying parts of electrically operated equipment shall be properly isolated or guarded. All noncurrent carrying metal parts shall be properly grounded.

10. All equipment and exhaust, steam or other lines carrying high temperatures located where they endanger employees or create a fire hazard shall be covered with suitable insulating material.

11. Exhausts from all equipment powered by steam or internal combustion engines shall be piped to the outside and so located that they do not endanger workmen or obstruct the view of the operator.

C. Inflammables.

1. Refueling any type of equipment with liquid fuel while the motor is running is prohibited.

2. Smoking or the use of open flames on or in the immediate vicinity of equipment being refueled is prohibited.

3. No solvent with a flash point below 100° F. shall be used for the cleaning of equipment or parts.

4. All gasoline or other highly inflammable fluids used on equipment shall be handled by pumps or in approved type safety cans. Gasoline, lubricating oil, and other inflammable fluids shall not be stored on equipment except in fuel tanks or approved type safety cans with a capacity of not more than 1 day's requirements.

5. Fuel tank filler openings shall not be located in such a position that spills or overflows can run down on a hot motor, exhaust pipe, or battery.

6. An approved type fire extinguisher shall be located on or in close proximity to all equipment.

D. Repairs.

1. All equipment shall be shut down for repairs and shall have an "Out of Order" sign posted; such sign shall not be removed until repairs are completed, equipment inspected and approved for service.

2. When repairs are necessary on mobile equipment, it shall be removed to a location which will not interfere with other operations and provide a safe workplace for repairmen.

3. Equipment which is suspended in slings or supported by hoist or jacks for repairs shall be blocked or cribbed before men are permitted to work underneath.

4. When repairs are made remote from the source of power on conveyors, cableways, etc., chains, blocking, or other such devices shall be used to prevent injury in case of accidental starting.

5. Before starting repairs on electrically powered equipment, the main switch shall be locked in open position. The key to switch lock shall be retained by the repairman.

E. Miscellaneous.

1. Accumulations of debris, oil, grease, oily rags, waste, etc., on equipment shall not be permitted.

2. Safe load capacity and or operating speeds shall be posted on all equipment and shall not be exceeded.

3. Equipment shall be placed on a firm foundation and properly secured in place.

4. Before moving mobile equipment, a survey of the area in which it is located shall be made to check for overhead wires, pipelines, excavations, and similar hazards.

5. Portable equipment shall not be moved into, out of, or operated in any area containing high voltage electric lines until the approval of the superintendent has been obtained.

6. Equipment shall not be operated within 10 feet of high voltage lines unless the power has been shut off.

7. Equipment shall not be located or operated so that slides, blasts, or the collapse of trenches or excavations can endanger employees.

SECTION 02—CRANES, HOISTS, AND DERRICKS 8316.02

A. Miscellaneous.

1. All cranes, hoists, and derricks shall have a minimum factor of safety of five.

2. All cranes, hoists, and derricks shall be equipped with proper dogs or pawls and braking equipment, which shall be capable of effectively braking a weight of at least one and one-half times the full rated load.

3. Extensions or outriggers will not be permitted unless designed by the manufacturer of the equipment on which they are to be used.

4. Capacity plates shall be attached to all cranes, hoists, and derricks. On boom cranes and derricks, they shall clearly indicate the safe load in tons for maximum and minimum positions of the boom and for at least two intermediate stations. These indications shall be for loads both with and without outriggers.

5. There shall be at least two full wraps of cable on the drums of cranes, hoists, and derricks at all times of operation.

6. Riding on loads, hooks, hammers, materials hoists, or buckets shall not be permitted.

7. Loads, booms, buckets, etc., shall not be swung over the heads of workmen.

8. While hoisting equipment is in operation, the operator shall not be permitted to perform any other work.

9. While a load is suspended from a crane or derrick, or on a hoist or elevator platform, the operator shall not leave his position at the controls until the load has been landed or the bucket or platform returned to the ground level.

10. Side pulls shall not be made with cranes or derricks. The crane boom shall be directly over the load to be lifted.

11. All slings, cables, chains, and other gear used in connection with cranes, hoists and derricks, shall be under supervision of and maintained by properly qualified persons.

B. Material—Hoists and Towers.

1. The shaftways and cars of hoists shall be constructed of sound material capable of sustaining the maximum rated load with a factor of safety of five. The tower shall be crossbraced and strutted and well guyed or strongly anchored to the building. Towers shall be vertically straight and plumb.

2. Landing platforms connecting the hoist shaftway to the building shall be provided with guard rails and toe boards.

3. Towers shall be provided with suitable platforms, with guard rails and toe boards at each level where men work.

4. The shaftways of hoists shall have a solid or substantial grille or lattice work enclosure on all sides not used for loading or unloading, extending to a height of at least 7 feet from each landing. The entrance to the shaftway shall be protected by a hinged bar placed at least 18 inches from the flush line of the shaftway. Where the entrance to shaftways is exposed to hazard from falling objects, a substantial covering shall be provided.

5. The cars of all hoists shall be provided at the top with a cover of either solid material or grille work. The covers shall be set back not more than 6 inches from the landing threshold and shall be hinged on the landing side not less than 18 inches back.

6. Builders' hoists shall not be operated when men are working in or on a hatchway or tower.

7. No person shall be permitted to enter a hoist pit until the car or bucket has been landed on suitable blocking or horizontal timbers placed across shaft opening.

C. Signal Systems.

1. A standard signal system shall be used on all cranes, hoists and derricks.

2. Hoist signals shall be given only by the designated signalman.

3. Where the signalman cannot be observed by the operator, a mechanical or electric signal system shall be used.

4. The signal code shall be posted adjacent to the signal device and at each work level and at operator's location and shall be clearly visible.

D. Pile Driving.

1. The hose on all steam or air hammers shall be lashed or otherwise fastened to prevent injury to workmen in case of a broken connection.

2. While inserting a pile or when not in use, the hammer shall be blocked in the leads.

SECTION 03—WOODWORKING MACHINERY

8316.03

A. Miscellaneous.

1. Woodworking machinery shall be operated only by properly qualified persons.

2. Woodworking machinery shall not be permitted to run unattended.

3. Suitable means shall be provided for the removal of sawdust, chips and shavings on all woodworking machinery.

4. Band saws shall not be operated at temperatures below 45° as they are liable to break when cold.

5. Cylindrical cutterheads shall be used on all jointers and planers.

6. A pusher stick or block shall be used in all close operations on circular saws, jointers, and sanders.

7. Cracked saws shall be taken out of service immediately. Drilling to prevent further cracking is prohibited.

8. All woodworking tools shall be kept sharp and maintained in safe working condition.

9. Sharpening, brazing, welding, and repairing of woodworking tools and equipment shall be done only by properly qualified persons.

B. Guarding.

1. All belts, pulleys, clutches, gears, sprockets, spindles, and other rotating and reciprocating parts shall be properly guarded.

2. The peripheral length of circular saws beneath saw tables shall be guarded.

3. Positive locking belt shifter or suitable stop and start buttons shall be provided on all woodworking equipment. These devices shall be located within easy reach of the operator.

4. Chip screens or safety goggles shall be provided at all locations where there is danger of injuries from sawdust, chips, or other flying particles.

5. Band saws shall be fully inclosed by a band guard except at the point of operation.

6. All swing cut off and radial saws shall be equipped with a limit stop which will prevent the outside edge of the saw from extending beyond the edge of the table.

7. That section of cutterhead in back of the guide shall be guarded on all jointers.

C. Point of Operation.

1. The point of operation on circular saws, band saws, jointers, borers, shapers, sanders, and other woodworking machinery shall be properly guarded.

2. All circular rip saws shall be provided with a hood guard, splitter, and kick-back device.

3. On all band saws a telescopic guard attached to the gauge block and extending to the upper wheel inclosure shall be used.

4. Where the volume of typical work is large, the use of a jig or fixture may be permitted with the approval of the superintendent.

FLOATING PLANT**SECTION 01—INSPECTION AND CERTIFICATION 8317.01**

A. Floating plant requiring an inspection and/or certificate under the regulations of the United States Coast Guard shall have such certificate posted before starting work. All other floating plant shall be inspected and a certificate of approval issued by the Division or District Engineer and posted before operation.

B. All floating plant shall be reinspected and the certificate of approval renewed annually. For major repairs or alterations, floating plant shall be taken out of service, reinspected, and the certificate returned or reissued before being placed in operation.

C. All persons requiring a license under the Regulations of the United States Coast Guard shall have in their possession a current license before being permitted to operate floating plant or equipment.

D. No person shall be permitted to operate any floating plant or equipment until it has been certified by the District Engineer that he is qualified and instructed in the safe method of operating such plant and equipment.

E. Weekly inspections shall be made in connection with accident prevention, sanitation and health, on all floating plant and a record kept of such inspections.

SECTION 02—GANGWAYS, GUARDRAILS, PLATFORMS, ETC. 8317.02

A. Gangways equipped with guardrails or life lines shall be provided for boarding or leaving all floating plant. Where the use of gangways is impracticable, ladders shall be provided. All gangways and ladders shall be properly secured to prevent slipping or falling.

B. All gangways, ladders, stairways, passageways, etc., shall be kept free of ice, snow, grease, mud, and other material. Sand, cinders, calcium chloride or other similar material shall be used where slippery surfaces cannot be avoided.

C. Nonslip surfaces shall be provided on all stair treads, ladders, floor plates, platforms, catwalks, and walkways, and on the weather side of all doorways opening on deck.

D. On stairways, companionways, and passageways where overhead clearance is limited suitable warning signs shall be posted.

E. Guardrails, life lines, or gratings shall be provided at all deck openings.

F. Handrails shall be installed on all stairways, ship ladders, companionways, and other such places where danger of falling exists.

G. Bulwarks, guardrails, or life lines shall be provided on all floating plant on which men are regularly employed or quartered. Similar provisions shall be made on all floating plant where practical.

H. All cargo and material runways or stages shall be provided with a substantial curb on each side at least six (6) inches high.

I. Pipe lines shall be equipped with walkways which shall have a minimum width of 20 inches. Walkways shall be securely anchored to the pipe line. A guardrail equivalent in strength to a wood rail (2 by 4 inches) shall be provided on one side of walkway and shall be secured to uprights at intervals of not more than eight (8) feet. Such guardrail shall be not less than thirty-six (36) nor more than forty-two (42) inches in height.

J. Catwalks or platforms with guardrails shall be provided at all locations where men are regularly employed above decks, floor plates, or over water.

K. All persons working aloft except on catwalks or platforms provided with guardrails shall be equipped with safety belts and life lines.

L. On all floating plant a walkway not less than two (2) feet wide shall be maintained outboard of all cargo or other materials stored on deck.

M. Safety lines consisting of three-fourth- ($\frac{3}{4}$ -) inch rope with knots twelve (12) inches apart shall be hung over the side of floating plant at intervals of not more than fifty (50) feet.

SECTION 03—MACHINERY AND DECKGEAR

8317.03

A. No person shall be permitted to enter a boiler, tank, cofferdam, double bottom, or other confined area until proper check has been made to insure a safe air supply, necessary protective equipment has been provided, and an attendant stationed at the entrance.

B. All belts, gears, chains, pulleys, couplings, projecting set screws, keys, and other rotating or reciprocating parts when

exposed to hazardous contact shall be enclosed or properly guarded.

C. All equipment and exhaust, steam, or other lines carrying high temperatures, where they endanger employees or create a fire hazard shall be guarded or covered by adequate insulation.

D. Engine throttle valves, boiler stops, starting switches and devices shall be locked in off position before starting repairs and key to such lock shall be retained by person making repairs.

E. Drip pans shall be installed at all locations where waste from engines or machinery may accumulate. Pans shall be emptied regularly.

F. Remote control shall be provided on floating plant for fuel shut-off valves, boiler stops, engine throttles, safety valves, and fixed fire extinguishing systems. Such controls shall be located on deck in such a position that they are protected against accidental operation but may be readily accessible to operate in an emergency.

G. Hooks, shackles, rings, pad eyes, chains, slings, etc., that have been bent, twisted, or otherwise damaged shall be removed from service.

H. All lines, gear, cargo, and other material shall be securely stowed or arranged in an orderly manner out of walkways, passageways, and work areas.

I. When handling lines on a power capstan or winch head, two men shall be used; one to handle lines and the other to operate such capstan or winch head.

J. The use of cranks on hand-powered winches or hoists is prohibited. Wheels without projecting spokes or pins shall be used.

K. Employees shall be required to stand clear of all chains, lines, and cables under strain.

L. All permanent running rigging when exposed to hazardous contact shall be properly guarded.

M. Before anyone is permitted to work on cutterheads, suction ladders, stern wheels or at such locations, chains, wire lashings, safety dogs or other similar devices shall be used to prevent accidental starting.

N. Axes in suitable brackets shall be provided forward and aft on all towing vessels.

O. All loose ends of wire rope shall be serviced or lashed to prevent hazardous contact.

SECTION 04—MISCELLANEOUS

8317.04

A. Suitable launches or tenders shall be provided for transportation to or from floating plant.

B. Employees shall not be permitted to sit or stand on deck railings, shafting, winch heads or other such hazardous places.

C. During inclement weather, at night, or in highly hazardous locations, no person, except watchman, shall be permitted to work alone.

D. Adequate lighting shall be provided at all times on all floating plant, pipelines, piers, landings and other adjacent areas used by the crew or other authorized persons.

E. All deck fittings and similar stumbling hazards shall be painted yellow.

F. A suitable whistle, siren, horn, or other such device shall be provided on all floating plant which is unattended by another vessel so equipped for signalling to shore or other vessels.

G. On all floating plant where ten (10) or more men are quartered, one man shall be on watch at all times to guard against fire, collision and other such hazards.

H. When engaged in operations where floating plant may be endangered by hurricanes, storms, or floods, plans shall be made in advance for removal of plant and evacuation of personnel in emergencies. Such plans shall be approved by the District Engineer.

I. Grappling irons or drags shall be provided at all locations where men are employed on floating plant or adjacent to water.

SECTION 05—LAUNCHES AND MOTORBOATS

8317.05

A. Launches and motorboats shall be operated by regularly designated operators or crews.

B. A daily inspection shall be made of all fuel lines, electric wiring, bilges, bilge pumps, exhaust lines, ventilating equipment, fire-extinguishing equipment, and lifesaving equipment on launches and motorboats.

C. All launches and motorboats having power plants located in cabins or compartments shall be equipped with a built-in CO₂ or other equally effective type of fire-extinguishing system. At least one carbon tetrachloride CO₂ or dry powder pressure type hand fire extinguisher shall be carried on all launches and motorboats including outboards.

D. All launches and motorboats having power plants located in cabins or compartments shall be equipped with an exhaust fan for ventilating engine spaces and bilges. Such fan shall be of the explosion-proof type and arranged so that the motor cannot be started until the engine space and bilges have been properly ventilated.

E. All electrical wiring shall be oilproof, wear-resisting cable. All switches in motor compartment shall be non-sparking type. Spark plugs shall be protected by insulating nipples or hoods.

F. No running motors, smoking, fires, open flames, or other sources of ignition shall be permitted while launches or motor boats are being refueled.

G. Gauge glasses shall not be installed on fuel tanks. Other means for gauging fuel shall be provided.

H. A cut-off valve shall be provided in the fuel line at the tank in all launches or motorboats to which shall be attached three separate pulls located remote from each other.

I. The fuel valve shall be closed at the tank on all launches and motorboats when shutting down for the night or more than eight hours.

J. All carburetors on launches or motorboats shall be equipped with a backfire trap or flame arrestor. A screened drip pan which is emptied continuously by suction from the intake manifold shall also be provided.

K. The maximum number of passengers permitted on all launches or motorboats shall be posted and shall not be exceeded.

L. No person except man tending lines shall be permitted to board or leave a launch or motorboat until such launch or motor boat has been securely tied up.

M. Life preservers shall be provided for all passengers and crew members of launches and motorboats.

N. The presence of fumes, vapors, or gases shall require a test to be made for inflammable or toxic concentrations and men shall not be permitted to occupy such quarters until safe to do so.

SECTION 06—DRILLS

8317.06

A. All floating plant having regular crews and on which men are employed or quartered the following drills are required to be held at least once monthly.

1. Boat or abandon ship drills.
2. Fire drills.
3. Man overboard or rescue drills. This applies to all locations where rescue skiffs are required under these regulations.

B. When drills are held in accordance with these requirements, each drill shall be held separately at least one hour apart.

C. A suitable electrical or mechanical alarm device shall be provided on all floating plant covered in these requirements.

D. A record of all drills shall be kept and be available for inspection by representatives of the Safety Branch.

E. All equipment and devices used in connection with such drills shall be inspected during drills and necessary repairs or replacements made. Such repairs and replacements shall be noted in record of drill.

SECTION 07—RING BUOYS

8317.07

A. Ring Buoys shall be provided and located where readily available under the following conditions:

1. On vessels, launches, barges and other floating plant up to one hundred (100) feet in length, two (2) shall be provided. Two (2) additional shall be supplied for each increase in length of one hundred (100) feet or fraction thereof.
2. On pipe lines, walkways, wharfs, piers, bulkheads, lock walls, etc., and on scaffolds or platforms extending over water, at intervals of not more than two hundred (200) feet.

B. At least one ring buoy as required under A-1 and every third one thereafter shall have an approved water light attached. For night operations every other ring buoy as required under A-2 shall have an approved water light attached.

C. On gasoline and oil barges or other locations where open flames may cause a fire or explosion, electric water lights shall be used.

D. At least one ring buoy on each side as required under A-1 and all ring buoys as required under A-2 shall have a life line attached and coiled so that it will not foul on release. Such line shall consist of not less than fifty (50) feet of one-half ($\frac{1}{2}$) inch rope.

SECTION 08—SKIFFS

8317.08

A. The permissible number of passengers in skiffs shall be the number that can safely be placed in fixed seats allowing not less than eighteen (18) inches of seat per passenger. Each skiff shall have the number of persons allowed to be carried plainly marked on each bow in letters and figures not less than three-fourths ($\frac{3}{4}$) of an inch high.

B. No person shall be permitted to use a skiff or small boat unless he is properly qualified and instructed in the safe handling of same.

C. Permission for the use of skiffs or small boats by employees of floating plant so located that there is no other access to shore, shall be obtained from the person in charge of the unit in advance; giving names, purpose or destination, time of departure and return.

D. One or more lifesaving skiffs shall be provided for each floating plant and for each shore establishment where men are working adjacent to water. Each skiff shall be kept afloat or ready for instant launching. Such skiffs shall be used only for lifesaving and lifesaving drills.

E. Each lifesaving skiff shall be equipped with not less than four (4) oars, with oarlocks securely attached to the gunwales, one (1) boat hook (ball point), and one (1) ring buoy with fifty (50) feet of one-half ($\frac{1}{2}$) inch line attached.

F. A life line of one-half ($\frac{1}{2}$) inch rope shall extend along outer side of gunwales and stern and shall be securely fastened at intervals of not more than three (3) feet. Such lines shall hang loosely and have a seine float placed in each bight.

SECTION 09—LIFE VESTS (WORK VESTS)

8317.09

A. Life vests shall be a type approved by the Office of the Chief of Engineers.

B. Life vests shall support a dead weight of sixteen (16) pounds for at least three hours in fresh water. All life vests in service shall be inspected once a month and tested by immersion at intervals of not over six months. Any vest which does not pass the test shall be removed from service.

C. All covers, pads, ties, fastenings, etc., shall be maintained in good condition.

D. A sufficient number of life vests shall be provided for all persons coming under these regulations.

E. Life vests shall be worn by all persons:

1. On pipeline, pontoons, rafts, and float stages, etc.
2. On floating plant not equipped with bulwarks, guardrails or safety lines.
3. On buildings or structures extending over water except where proper scaffolds or platforms with guardrails, or safety belts and life lines are provided.
4. When working over the side of a vessel or floating plant.
5. Working alone or at night in hazardous locations.
6. In skiffs, small boats or launches except when in an enclosed cabin or cockpit.

SECTION 10—FIRE PREVENTION AND PROTECTION

8317.10

A. All combustible debris on floating plant shall be continually removed.

B. On all floating plant fifty (50) feet or over in length constructed of or having on board combustible material, not less than four (4) fire buckets with lanyards attached shall be provided. On floating plant less than fifty (50) feet in length and on all launches, motorboats, work boats, etc., at least one fire bucket shall be provided. One two-and-one-half (2½) gallon soda and acid or pump tank extinguisher may be substituted for each fire bucket.

C. Floating plant over fifty (50) feet in length on which ten (10) or more men are regularly employed or quartered shall be provided with a fire pump and sufficient outlets and one and one-half (1½) inch hose to reach any point on board.

D. All gasoline storage areas, paint lockers, lamp lockers, motor compartments, fire and engine rooms, shall be equipped with a "built-in" CO₂ foam or steam fire extinguishing system. These locations shall also be equipped with one or more approved type hand fire extinguisher.

E. Gasoline and other inflammable fluids shall not be stored below decks on floating plant except in tanks especially provided for the purpose. Such tanks shall be equipped with fill pipes and vents carried outside the hull or structure at a safe location. All vents shall be equipped with flame arrestors.

F. Gasoline or other inflammable fluids in drums, and inflammable or toxic gases shall be stored on deck in a safe location. All containers shall be properly secured, protected

against injury and so arranged that they can be thrown overboard on emergency.

G. Handling of all inflammable fluids shall be in approved type safety cans.

H. Oily rags, waste, etc., shall be kept in covered metal containers.

SECTION 11—SANITATION—LIVING QUARTERS 8317.11

A. All water used for drinking, cooking, dishwashing, and bathing shall be from a source known to be free of pollution. If such water is not available, a water treatment unit or still shall be provided.

B. On all vessels using other than potable water at outlets in galley, toilets, or other locations where it may be mistaken for drinking purposes shall have all such outlets marked "UNFIT TO DRINK."

C. Hot and cold running water shall be supplied to all galleys, toilet rooms, showers, and laundry trays.

D. Water closets shall be provided in the ratio of one for each fifteen (15) persons or fraction thereof.

E. Urinals may be substituted for one-third ($\frac{1}{3}$) of the required number of water closets.

F. Open-front seats shall be provided in all water closets.

G. All toilet seats shall be so constructed or finished as to be impervious to moisture.

H. All water closets and urinals shall be provided with a sufficient supply of water for flushing purposes and automatic or manual flushing arrangements.

I. Wash bowls shall be provided in the ratio of one for each fifteen (15) persons or fraction thereof.

J. Shower or tub baths shall be provided in the ratio of one for each fifteen (15) persons or fraction thereof.

K. All living quarters, toilets, galleys, and washrooms shall be maintained in a clean and sanitary condition.

L. All mattresses, pillows, and blankets shall be disinfected before being issued to an employee.

M. Clean bed linen and towels shall be provided weekly.

N. A reading light shall be installed at each bunk in crew's quarters of floating plant.

O. Individual clothes lockers shall be provided on floating plant where men are quartered.

P. Heating arrangements capable of maintaining a temperature of 70° in living quarters shall be provided on all floating plant having regular crews or on which men are quartered.

Q. Adequate ventilation shall be provided in living quarters and work areas. Where natural circulation is insufficient, fans or other mechanical ventilation shall be provided.

R. Insect screens shall be provided for all living quarters.

S. Where communicable diseases or vermin are present on floating plant, all such plant or sections thereof which have been affected shall be fumigated. The person in charge shall be responsible for the evacuation of all persons in affected areas before starting to fumigate.

T. Warning signs shall be posted at all locations where fumigating is taking place, and such signs shall not be removed or persons permitted to enter until such areas have been properly ventilated and pronounced safe for occupancy by the person in charge.

SECTION 12—MEDICAL SUPPLIES AND FIRST AID 8317.12

A. Floating plant requiring medicine chests under the requirements of the United States Public Health Service shall be so equipped.

B. Floating plant not included in paragraph A, on which men are quartered and which are so located that such supplies and medical attention are not available, shall be provided with necessary quantities of the following:

Alcohol—Cleansing and disinfectant for wounds.

Aspirin or Empirin compound—Use to reduce fever and to relieve headache, rheumatism, or pain in the joints and muscles. Give in doses of 1 to 3 tablets every 4 hours if necessary. Never give more than 12 tablets in 24 hours.

Aromatic spirits of ammonia.

Absorbent cotton, $\frac{1}{4}$ lb. rolls (1st grade).

Adhesive plaster, 2" x 5 yards.

Applicators, 6" wooden.

Brown mixture—20 grain tablet, cough; allow tablet to dissolve on tongue and swallow solution.

Bicarbonate of soda, 5-grain tablets.

Boric acid, powder.

Bandage, 3" x 10 yards.

Belladonna plaster, 7" x 1 yard, in tin cans.

- Castor oil, purgative; 1 to 4 tablespoonfuls.
- Compound cathartic pills, purgative; give 1 to 2 pills.
- Cascara, aromatic, laxative; give 2 teaspoonfuls.
- Tannic acid jelly or Foille—for burns.
- Camphorated oil, $\frac{1}{2}$ pint.
- Dropper, medicine, curved.
- Ear drops, carbolic acid, 1 fluid dram; glycerine, 7 fluid drams.
- Glass, medical, graduated 4 tablespoons to 8 teaspoons.
- Hot water bottle, or electric heating pad where current is available; or thermat heating pad or equal.
- Ice bag.
- Ichthyl ointment, 20 percent, collapsible tube.
- Magnesium sulphate (epsom salts), cathartic; 2 to 4 table-spoonfuls dissolved in water.
- Mercurial ointment (blue ointment)—Used in destroying crab lice and sometimes as a dressing for chronic ulcers. Smear over hairy parts and allow to remain for a day or two, then wash thoroughly with soap and water.
- Milk of bismuth—For relief of diarrhea. Give 1 table-spoonful every two hours until arrested; do not give over four doses.
- Oil of clove—Relieve toothache; apply with absorbent cotton.
- Quinine sulphate, 5-grain tablets or capsules for malaria. Give 10 grains three times daily for three or four days, then 10 grains every night for eight weeks.
- Spray, insecticide liquid.
- Sun cholera mixture, 5 grains.
- Compound methyl salicylate ointment—For rheumatism, sprains and bruises: $\frac{3}{4}$ -oz. tubes and 1-lb. jars.
- Tincture of iodine, 3 $\frac{1}{2}$ % solution; 2-oz. bottles with air-tight caps.
- Thermometer, clinical.
- Tongue depressors, wooden.
- Vaseline, ointment; $\frac{1}{3}$ -lb. jars.
- Zinc oxide—Useful in cases of inflamed, itching or irritated skin; for eruptions of the skin and sunburn.
- Scissors, 4" bandage type.
- Neo-synephrin hydrochloride jelly, $\frac{1}{2}$ % and/or neo-synephrin hydrochloride solution, $\frac{1}{4}$ %; for relief and treatment of head colds.

Sodium chloride (salt) tablets, 10 grains, each; for prevention of heat exhaustion.

Five-percent alcoholic solution of ferric-chloride, 30 percent glycerine; or 10-percent solution of tannic acid in water; for poison ivy, oak and sumac.

Oil of citronella—For mosquito control.

Ten-percent solution of sulphur ointment—For chigger bites.

Cresol—Compound disinfectant for sanitary purposes; used in 1- to 5-percent strength; two teaspoonfuls added to 1 quart of water will make 1-percent solution.

One copy of "The Ship's Medicine Chest and First Aid at Sea," published by the United States Public Health Service, shall be provided.

C. On all floating plant, 16-unit first-aid kits shall be provided in the ratio of one for each 25 persons or fraction thereof and so located as to provide maximum accessibility.

WAR DEPARTMENT
OFFICE OF
THE CHIEF OF ENGINEERS
CONSTRUCTION DIVISION
WASHINGTON

1-A

**SAFETY REQUIREMENTS
IN
EXCAVATION-BUILDING-CONSTRUCTION**

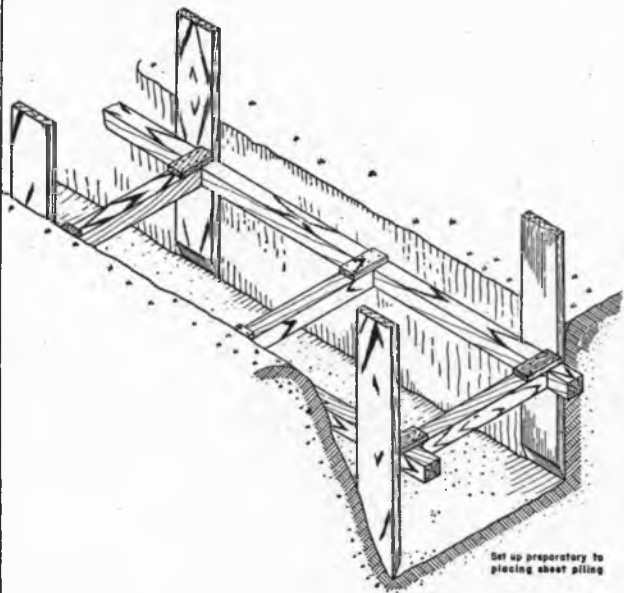

SAFETY SECTION	
OPERATIONS BRANCH	
TRENCH SHORING	
DESIGNED BY	REVIEWED, APPROVED
U.S. M.	<i>Joseph D. ...</i>
DATE	
8-1-41	<i>W. Blanchard</i>
	PAID 2000 344788

SPER-10-1A

WAR DEPARTMENT
OFFICE OF THE CHIEF OF ENGINEERS
CONSTRUCTION DIVISION
WASHINGTON

2-A

**SAFETY REQUIREMENTS
IN
EXCAVATION-BUILDING-CONSTRUCTION**

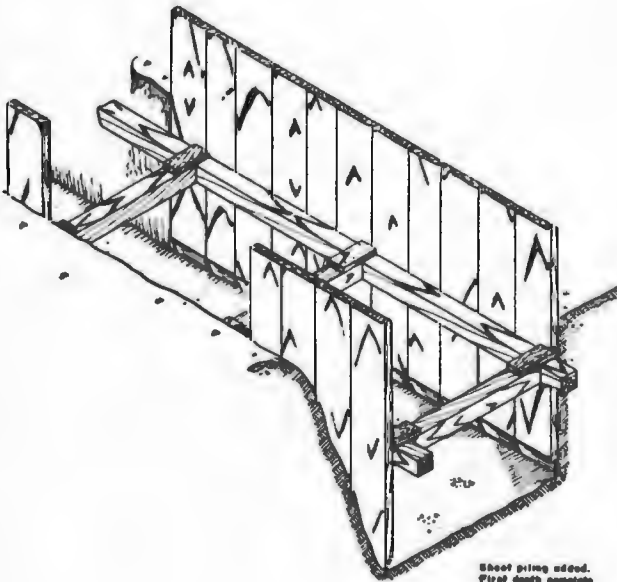

Sheet piling used.
First depth complete.

SAFETY SECTION	
OPERATIONS BRANCH	
TRENCH SHORING	
DESIGNED BY	ENGINEER APPROVED
BY	
2-4-01	<i>[Signature]</i>

U.S. DEPARTMENT
OF THE ARMY
ENGINEERING CENTER
FORT BELLEVILLE, ILLINOIS

3-4

SAFETY REQUIREMENTS
IN
ELEVATION-BUILDING-CONSTRUCTION

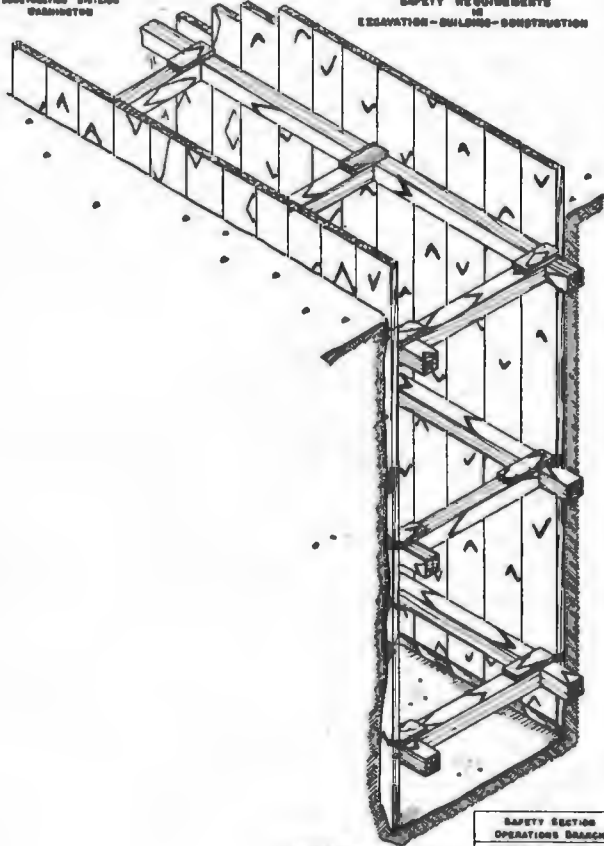

Shoring, full depth

SAFETY SECTION	
OPERATIONS BRANCH	
FIG. NO.	4-2
DATE	1948
BY	<i>[Signature]</i>
CHKD.	<i>[Signature]</i>

WAR DEPARTMENT
OFFICE OF
THE CHIEF OF ENGINEERS
CONSTRUCTION DIVISION
WASHINGTON

SAFETY REQUIREMENTS
IN
EXCAVATION - BUILDING - CONSTRUCTION

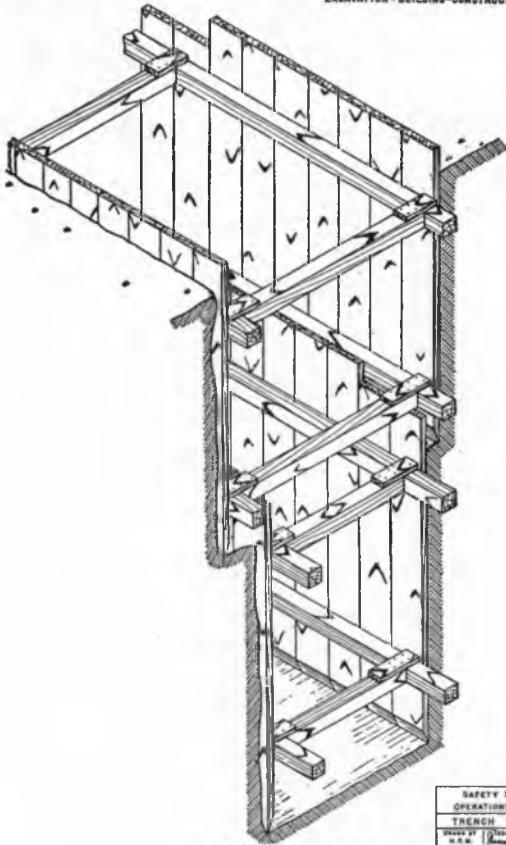

Method of bracing when two lengths
of sheet piling are used.

SAFETY SECTION	
OPERATIONS BRANCH	
TRENCH SHORING	
ISSUED BY	Approved, OFFICE
	U.S.A. <i>Samuel C. ...</i>
DATE	
2-1-41	<i>W. B. ...</i>

SPDL 10-4

WAR DEPARTMENT
OFFICE OF THE CHIEF OF ENGINEERS
CONSTRUCTION DIVISION
WASHINGTON

6-2
**SAFETY REQUIREMENTS
IN
EXCAVATION-BUILDING-CONSTRUCTION**

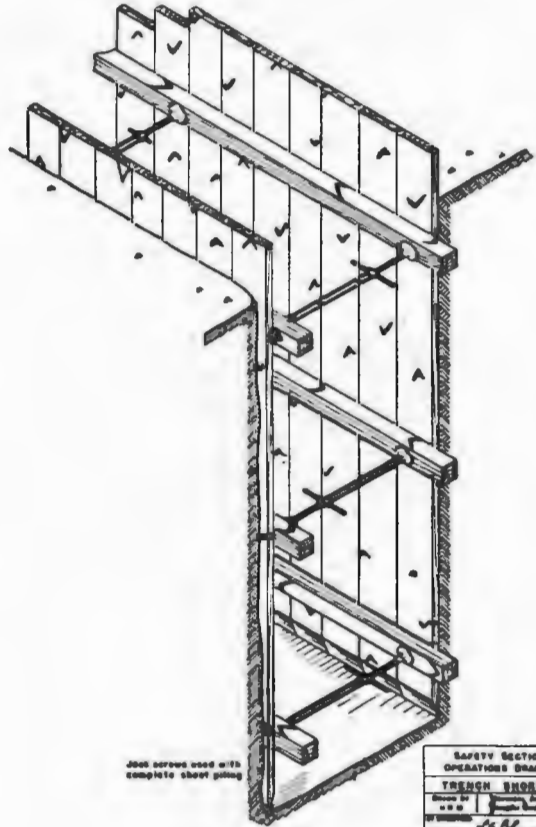

Jaw screws used with complete sheet piling

SAFETY SECTION
OPERATIONS DRAWING
TRENCH SHORING
Scale 1/4"
BY ENGINEER *[Signature]*
C-1-20 *[Signature]*
1918

WAR DEPARTMENT
 OFFICE OF
 THE CHIEF OF ENGINEERS
 CONSTRUCTION DIVISION
 WASHINGTON

6-A

SAFETY REQUIREMENTS
 IN
 EXCAVATION - SHIELDING-CONSTRUCTION

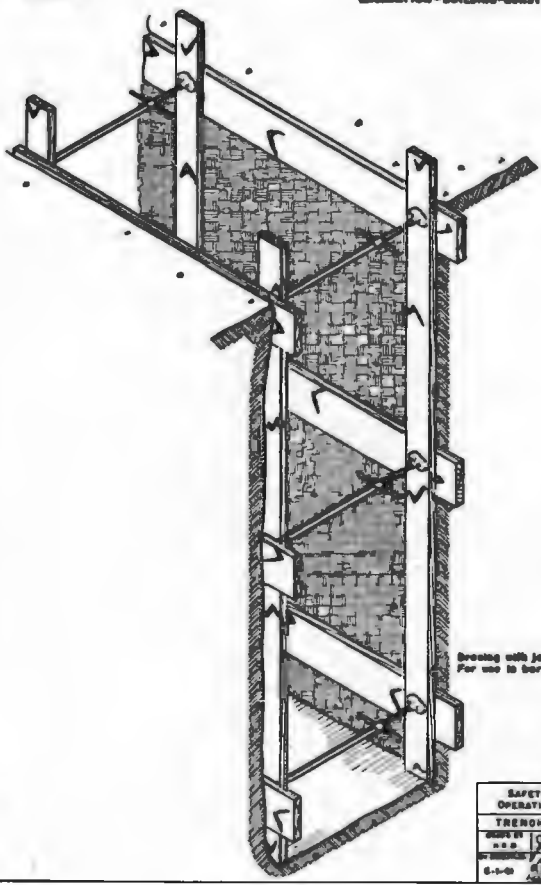

Bracing with joint covers.
 For use in hard soil.

SAFETY SECTION	
OPERATIONS SECTION	
TRENCH SHORING	
DATE	APPROVED
6-1-31	<i>[Signature]</i>
SPECIAL NO. 1	

WAR DEPARTMENT
OFFICE OF
THE CHIEF OF ENGINEERS
CONSTRUCTION DIVISION



SAFETY EMBLEM
BY PERMISSION OF
NATIONAL SAFETY
COUNCIL.

INSERT APPROPRIATE NAME HERE:
INFIRMARY OR FIRST AID STATION

SPECIFICATIONS

COLOR: DARK GREEN LETTERS, FIELD
AND BORDER ON WHITE BACKGROUND.
DO NOT LETTER WITHIN CROSS

MATERIAL: WOOD, PLYWOOD, OIL-
CLOTH, ETC. (OPTIONAL)

INSIGNIA SHOULD BE PAINTED ON
BOTH SIDES OF MATERIAL WHEN
PLACED UPON ROOF...FLOOD LIGHT
OR OTHERWISE ILLUMINATE FOR
NIGHT OPERATION.

SAFETY SECTION
OPERATIONS BRANCH

INSIGNIA FOR INFIRMARY
AND FIRST AID STATION

APPROVED:

Lt. Blanchard

7-10-42

CHIEF, SAFETY SECTION

SPEOL-6

Reference: Circular Letter No. 1911
Construction Division No. 505

THE DEPARTMENT
OF THE CITY OF BOSTON
CONSTRUCTION DIVISION
BOSTON

**SAFETY REQUIREMENTS
IN
EXCAVATION-BUILDING-CONSTRUCTION**

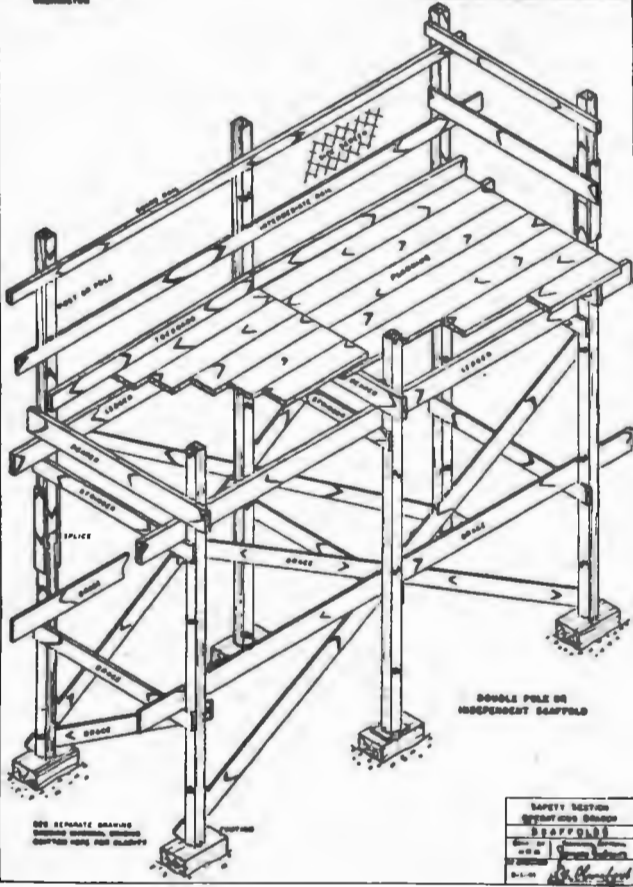

**DOUBLE POLE OR
INDEPENDENT SCAFFOLD**

SEE SEPARATE DRAWING
SHOWING DETAILS, DIMENSIONS
AND OTHER DATA FOR SAFETY

SAFETY DESIGN
EXCAVATION AND SCAFFOLD
SCAFFOLD
 DIVISION OF CONSTRUCTION
 CITY OF BOSTON
 0-1-01

U.S. DEPARTMENT
OFFICE OF
THE SECRETARY OF COMMERCE
CONSTRUCTION DIVISION
WASHINGTON

SAFETY REQUIREMENTS
IN
CONSTRUCTION-BUILDING-CONSTRUCTION

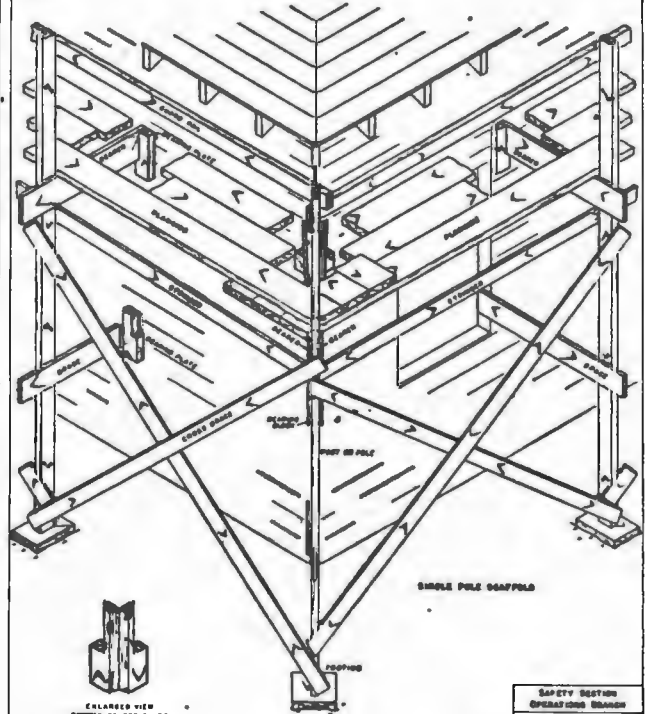

SINGLE POLE SCAFFOLD



ENLARGED VIEW
OF BEAM PLATE

SAFETY SYSTEM	OPERATION DIVISION
SCAFFOLD	
NO. 1	SAFETY SYSTEM
NO. 2	SAFETY SYSTEM
NO. 3	SAFETY SYSTEM
NO. 4	SAFETY SYSTEM
NO. 5	SAFETY SYSTEM
NO. 6	SAFETY SYSTEM
NO. 7	SAFETY SYSTEM
NO. 8	SAFETY SYSTEM
NO. 9	SAFETY SYSTEM
NO. 10	SAFETY SYSTEM

THE DEPARTMENT
OFFICE OF
THE CHIEF OF CONSTRUCTION
CONSTRUCTION DIVISION
WASHINGTON

**SAFETY REQUIREMENTS
FOR
ERECTOR-BUILDING-CONSTRUCTION**

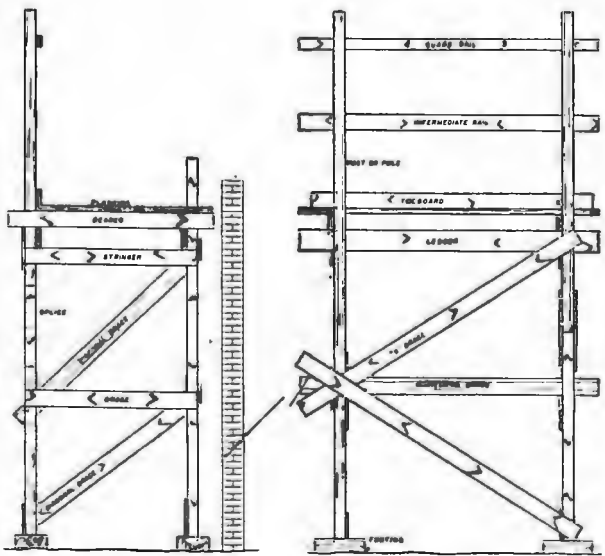

END VIEW

DOUBLE POLE OR
INDEPENDENT SCAFFOLD

BACK VIEW

SAFETY SECTION
OPERATIONS BRANCH
SCAFFOLDS
ISSUED BY THE CHIEF OF CONSTRUCTION
DIVISION
APPROVED BY THE CHIEF OF CONSTRUCTION
DIVISION
1918

U.S. DEPARTMENT
OF LABOR
BUREAU OF MINES
CONSTRUCTION DIVISION
WASHINGTON

SAFETY REQUIREMENTS
IN
ERECTOR-BUILDING-CONSTRUCTION

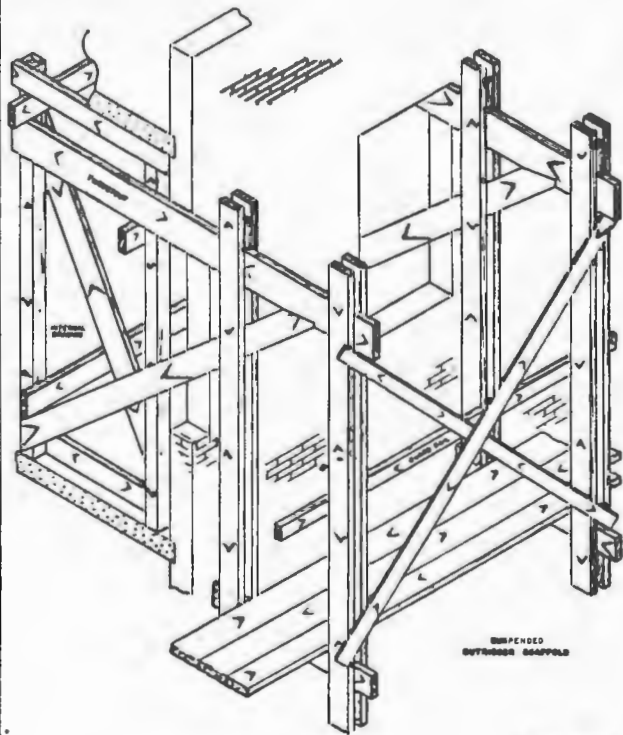

SUSPENDED
OUTSIDE SCAFFOLD

SAFETY SECTION
OPERATIONS DIVISION
SCAFFOLDS
Drawing No. 1
Scale 1/8" = 1'-0"
1918
U.S. DEPARTMENT OF LABOR
BUREAU OF MINES
CONSTRUCTION DIVISION
WASHINGTON, D.C.

THE DEPARTMENT
OF
THE CITY OF LOS ANGELES
CONSTRUCTION DIVISION
REGISTERED

**SAFETY REQUIREMENTS
ON
EXCAVATION - BUILDING - CONSTRUCTION**

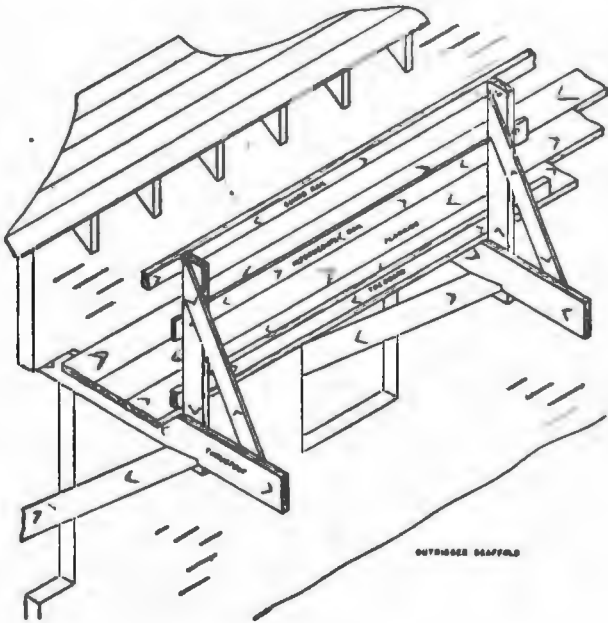

OUTRIGGER SCAFFOLD

SAFETY SECTION
OPERATING MANUAL
SCAFFOLDS
ISSUED BY
DATE
BY
SAFETY SECTION

SAFETY SECTION

THE DEPARTMENT
OF THE CITY OF PHOENIX
CONSTRUCTION DIVISION
CONSTRUCTION

SAFETY REQUIREMENTS
FOR
EXCAVATION-BUILDING-CONSTRUCTION

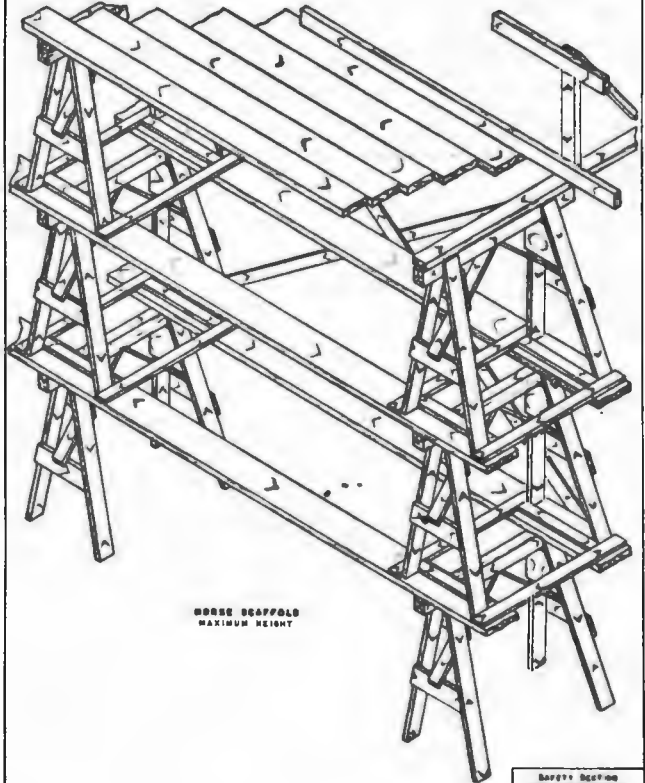

HORSE SCAFFOLD
MAXIMUM HEIGHT

SAFETY SECTION
OPERATING SECTION
SCAFFOLD
DATE: _____
BY: _____
CHECKED BY: _____
APPROVED BY: _____
0 - 10

U.S. DEPARTMENT
OF THE ARMY
OFFICE OF THE CHIEF OF ENGINEERS
CONSTRUCTION DIVISION
WASHINGTON

**SAFETY REQUIREMENTS
IN
ERECTING - REPAIRING - DEMOLISHING**

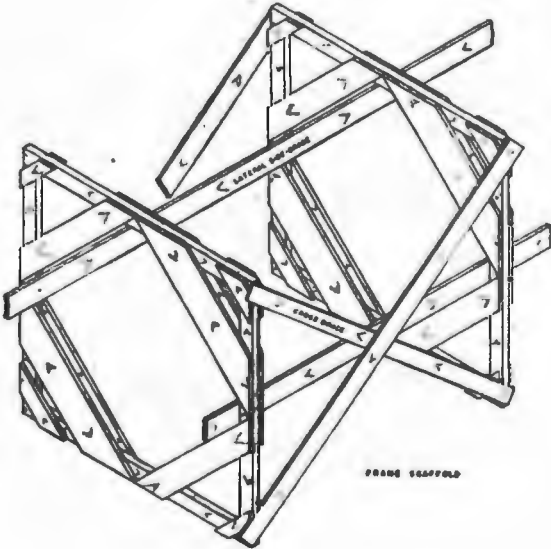

FRAME SCAFFOLD

SAFETY SECTION	
OPERATIONS BRANCH	
SERIAL	
DATE	BY
1-1-42	<i>[Signature]</i>

THE DEPARTMENT
OFFICE OF THE CHIEF OF BUSINESS
CONSTRUCTION DIVISION
WASHINGTON

**SAFETY REQUIREMENTS
IN
EXCAVATION-BUILDING-CONSTRUCTION**

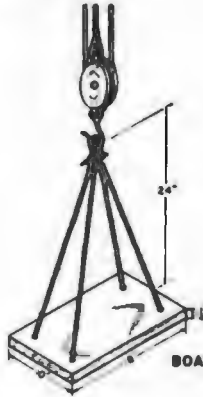

BOATSWAIN'S CHAIR

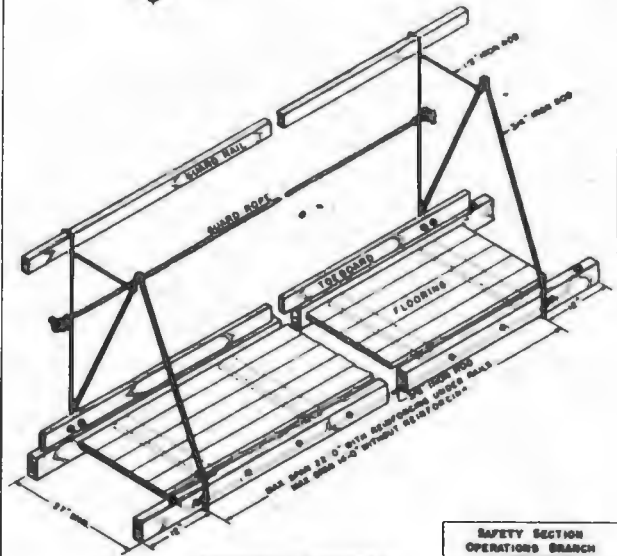
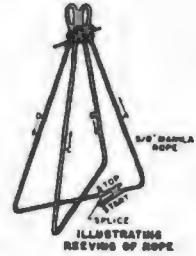

**SWINGING SCAFFOLD
LADDER PLATFORM TYPE**

SAFETY SECTION OPERATIONS BRANCH
SCAFFOLDS
Checked by <i>[Signature]</i>
By <i>[Signature]</i>
6-1-42 <i>[Signature]</i>

WAR DEPARTMENT
OFFICE OF
THE CHIEF OF ENGINEERS
CONSTRUCTION DIVISION
WASHINGTON

SAFETY REQUIREMENTS
IN
EXCAVATION-BUILDING-CONSTRUCTION

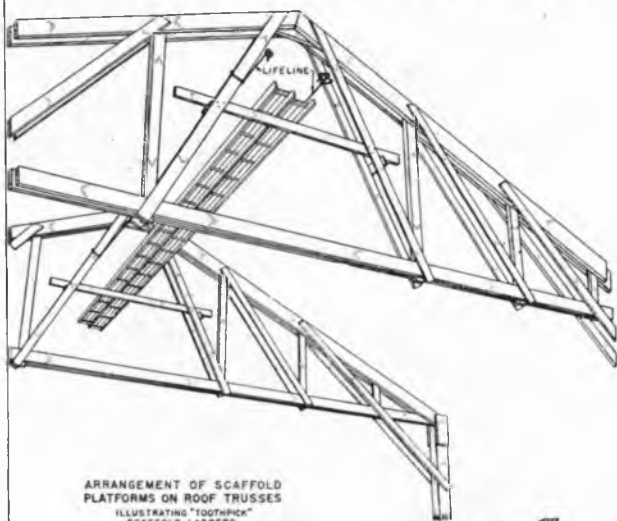

ARRANGEMENT OF SCAFFOLD
PLATFORMS ON ROOF TRUSSES
ILLUSTRATING "TOOTHPICK"
SCAFFOLD LADDERS

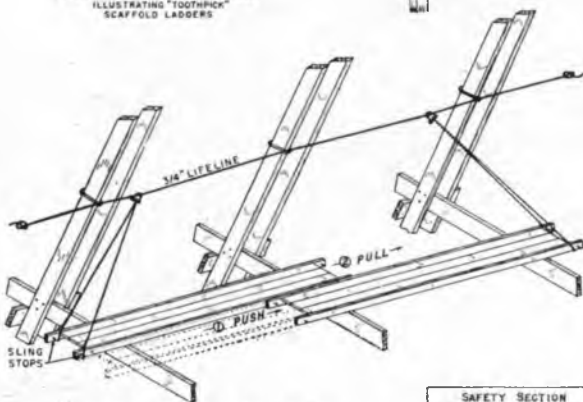

ILLUSTRATING USE OF LIFELINE
FOR MOVING SCAFFOLD PLATFORMS

SAFETY SECTION OPERATIONS BRANCH SCAFFOLDS
TECHNICAL APPROVAL <i>W. H. ...</i>
BY DIRECTION 4-15-42 <i>C. G. ...</i> CHIEF, SAFETY BRANCH
SP-101-3

THE DEPARTMENT
OF THE CITY OF BOSTON
CONTRACTED SERVICE
COMMISSION

SAFETY REQUIREMENTS
IN
EXCAVATION-ENGINEERING-CONSTRUCTION

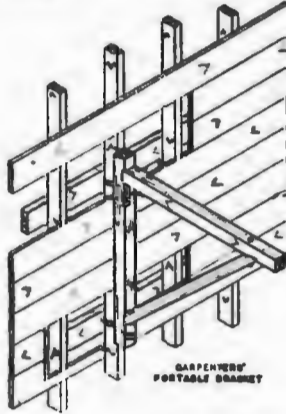

CARPENTER'S
PORTABLE SCAFFOLD

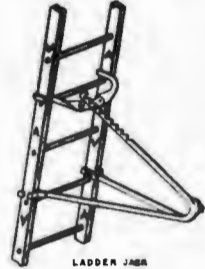

LADDER JACK

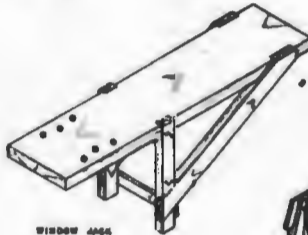

WINDOW JACK

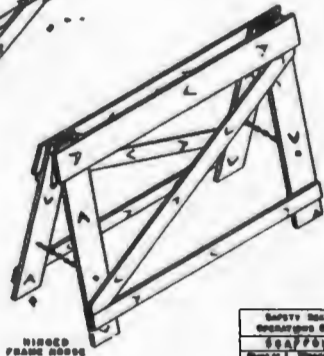

WINGED
FRAME SCAFFOLD

SAFETY SECTION	
REGULATIONS DIVISION	
SCAFFOLD	
DATE OF	REVISION
BY	BY
0-1-00	

WAR DEPARTMENT
OFFICE OF
THE CHIEF OF ENGINEERS
CONSTRUCTION DIVISION
WASHINGTON

**SAFETY REQUIREMENTS
IN
EXCAVATION-BUILDING-CONSTRUCTION**

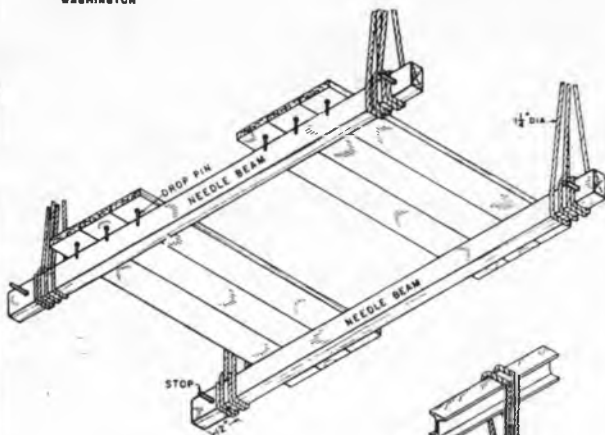

NEEDLE BEAM SCAFFOLD

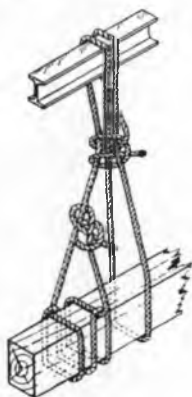

**ENLARGED VIEW
SCAFFOLD HITCH
AND FASTENING**

SAFETY SECTION OPERATIONS BRANCH	
SCAFFOLDS	
TECHNICAL APPROVAL:	
<i>Walter H. [Signature]</i>	
BY DIRECTOR	
4-19-42 <i>L. A. [Signature]</i>	
SAFETY	

WAR DEPARTMENT
OFFICE OF
THE CHIEF OF ENGINEERS
CONSTRUCTION DIVISION
WASHINGTON

SAFETY REQUIREMENTS
IN
EXCAVATION - BUILDING - CONSTRUCTION

SINGLE RUNG TYPE LADDER

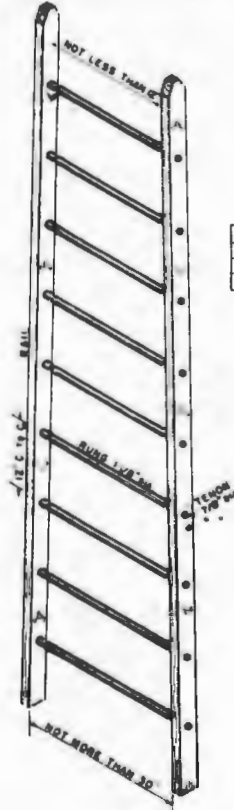

LENGTH	RUNG SECTIONS
UP TO 10'	1-2 1/2" X 2-1/2"
11' TO 20'	1-3 1/2" X 2-3/4"
21' TO 25'	1-4 1/2" X 2-5/8"

SPACING 36" MAX. O.C.

SAFETY SECTION OPERATIONS BRANCH	
LADDERS	
Drawn by H. R. M.	Technica. Approval <i>[Signature]</i>
By Direction	<i>[Signature]</i>
8-1-41	

**SAFETY REQUIREMENTS
IN
EXCAVATION-BUILDING-CONSTRUCTION**

**WAR DEPARTMENT
OFFICE OF
THE CHIEF OF ENGINEERS
CONSTRUCTION DIVISION
WASHINGTON**

**BUILDERS PORTABLE
SINGLE CLEAT LADDER**

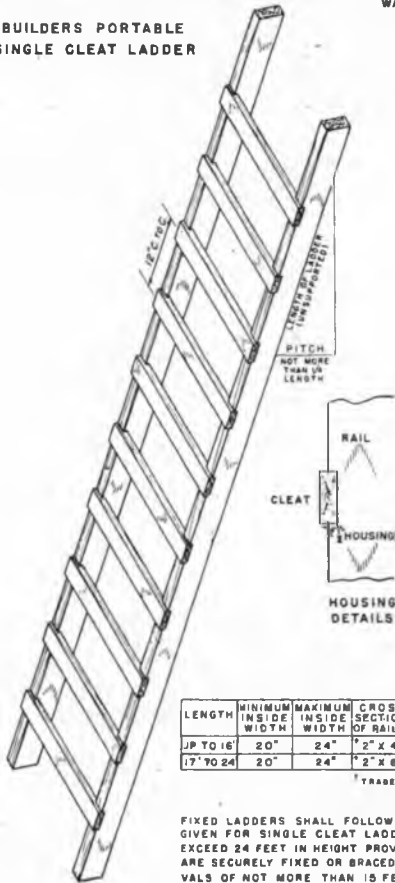

LENGTH	MINIMUM INSIDE WIDTH	MAXIMUM INSIDE WIDTH	CROSS SECTION OF RAILS	CROSS SECTION OF CLEATS
JP TO 16	20"	24"	2" X 4"	1" X 3"
17' TO 24	20"	24"	2" X 6"	1" X 4"

*TRADE SIZES

FIXED LADDERS SHALL FOLLOW DIMENSIONS GIVEN FOR SINGLE CLEAT LADDERS AND MAY EXCEED 24 FEET IN HEIGHT PROVIDED THEY ARE SECURELY FIXED OR BRACED AT INTERVALS OF NOT MORE THAN 15 FEET

**SAFETY SECTION
OPERATIONS BRANCH
LADDERS**

DRAWN BY *J. M. M.* TECHNICAL APPROVAL *J. M. M.*

BY DIRECTION

9-1-41

R. A. Blanchard
CHIEF, SAFETY SECTION



WHIPPING-STEP 1
ROUNDS OPENED TO CLARIFY

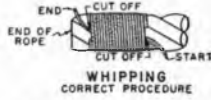

WHIPPING
CORRECT PROCEDURE

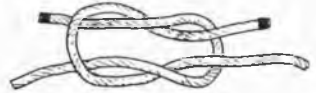

SQUARE KNOT



SHEET BEND



BOWLINE

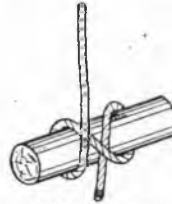

CLOVE HITCH



ROLLING HITCH



RUNNING
BOWLINE

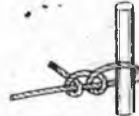

TWO HALF
HITCHES



ROUND TURN AND
TWO HALF HITCHES

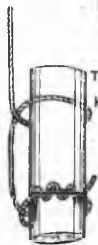

TIMBER HITCH
AND
HALF HITCH

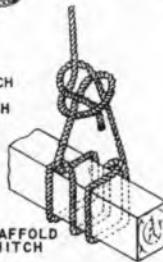

SCAFFOLD
HITCH

SAFETY SECTION OPERATIONS BRANCH	
ROPES	
CODE 8304.09	TECHNICAL APPROVAL <i>[Signature]</i>
BY DIRECTION: 4-1-42 <i>[Signature]</i> SAFETY SECTION	

(Amendment to "Safety Requirements
for Excavation, Building, Construc-
tion" 15 December 1943.)

MOTOR VEHICLES

SECTION 01 - DEFINITION 8318.01

A motor vehicle, hereinafter referred to as a vehicle, shall mean every self-propelled vehicle used for transporting persons or property except vehicles designed for exclusive use off the highway.

SECTION 02 - OPERATOR'S PERMIT 8318.02

Every person regularly or occasionally operating a government vehicle shall have passed the prescribed driving test and have in his possession at all times while operating such vehicle a U. S. Army Motor Vehicle Operator's Permit (W.D.O.O. Form 7360) issued by the Division, District or Area Engineer or Commanding Officer of Independent Establishments.

SECTION 03 - GENERAL 8318.03

A. No vehicle shall be placed in service until it has been inspected by a qualified person and found to be in safe operating condition.

B. All vehicles and their equipment shall be inspected weekly.

C. Vehicles and/or equipment found to be in unsafe operating condition shall be removed from service, repaired or replaced, and reinspected before being placed in service again.

D. Current records of all inspections shall be kept on file and be available for review by representatives of the Safety and Accident Prevention Branch.

E. No operator shall be permitted to operate a motor vehicle for more than ten (10) hours in any one day or more than sixty (60) hours in any one week. Exceptions to this regulation will only be made under authorization of the Division, District or Area Engineers or Commanding Officer of Independent Establishments.

F. All temporary trestles, ramps, fills, roads and other such facilities shall be of sufficient width and designed, constructed and maintained to provide for safe operation. Safe load capacities of such facilities shall be posted.

G. Vehicle trestles or ramps on which foot traffic is permitted shall be provided with a suitable walkway and guardrail.

H. Where vehicles are required to back up to open pits, hoppers, excavations or similar locations, suitable barriers or curbs not less than eight (8) inches high shall be provided.

I. Barricades, signs and warning lights shall be provided at all locations where men are working adjacent to highways or vehicular traffic.

SECTION 04 - EQUIPMENT

8318.04

A. All vehicles or combination of vehicles, except motor cycles, shall be equipped with the following lights:

1. Two headlights; one on either side.
2. One red taillight and one red or amber stop light.

B. Motorcycles shall be equipped with one headlight and one red tail lamp.

C. All vehicles or combinations of vehicles shall be equipped with lights and reflectors in accordance with the laws and regulations of the states in which operated.

D. All lamps required to be securely and permanently affixed to any vehicle shall be electric.

E. Every vehicle or combination of vehicles, except trailers with a gross weight of less than 3000 pounds, shall be equipped with brakes on each of the vehicles adequate to control the movement and to stop and to hold such vehicle or combination of vehicles under all conditions of service.

F. Braking systems on every combination of vehicles shall be so designed as to be in approximate synchronism on all wheels and developing the required braking effort on the rearmost wheels first. Such design shall also provide for application of the brakes by the driver of the towing vehicle from his cab.

G. Braking systems on all combinations of vehicles shall be so designed and connected that in case of accidental break away of the towed vehicle the brakes shall be automatically applied and application continued for a period of not less than fifteen (15) minutes.

H. Every vehicle or combination of motor vehicles shall be capable at all times and under all conditions of being stopped on a dry, smooth, level road upon application of the service brake within the distances specified below.

	<u>Stopping Distance</u>
	<u>at 20 M. P. H.</u>
Vehicles or combinations of vehicles having brakes on all wheels.....	30 feet
Vehicles or combinations of vehicles not having brakes on all wheels.....	45 feet

I. Every vehicle shall be equipped with a speedometer in proper operating condition.

J. Every vehicle shall be equipped with an adequate warning device in proper operating condition.

K. Every vehicle shall be equipped with a suitable windshield wiper.

L. In localities where weather requires, every vehicle shall be equipped with a suitable defrosting device.

M. All vehicles shall be equipped with a rear view mirror so arranged to give a clear view of the highway to the rear.

N. Suitable cabs, cab shields and other necessary protection shall be provided on all vehicles to protect the driver from the elements, falling materials, etc.

O. Non-slip surfaces shall be provided on running boards and steps of all vehicles.

P. All glass used in windshields, windows and doors of vehicles shall be "safety glass".

Q. All towing devices used on any combination of vehicles shall be designed by the manufacturer of such equipment and shall be structurally adequate for the weight drawn and securely and properly mounted.

R. A locking device shall be provided on every fifth wheel mechanism and tow bar arrangement which will prevent the accidental separation of towed and towing vehicles.

S. Every full trailer shall be coupled with safety chains or cables to the towing vehicle. Such chain or cable shall be adequate to prevent the separation of the vehicles in the event of failure of the tow bar.

T. All dump trucks shall be equipped with hinged struts permanently attached and capable of being locked in the raised position or other similar device to prevent accidental lowering of the body.

U. All operating levers on hoists shall be equipped with a latch or other device which will prevent accidental starting or tripping of the mechanism.

V. Trip handles for tail gates on all dump trucks shall be so arranged that load may be dumped from the cab of truck.

W. Tail gates of dump trucks shall be equipped with "D" handles or other similar arrangement for handling.

X. All vehicles except motorcycles shall be equipped with a power operated starting device. Cranks shall be used only in case of failure of power operated starting device or while making motor adjustments.

Y. All vehicles shall be equipped with the following emergency equipment:

1. One spare bulb for each type used.
2. One spare fuse for each type used.

Z. All buses, trucks and combinations of vehicles with a carrying capacity of one and one-half tons or over shall be equipped with the following emergency equipment:

1. One carbon tetrachloride or carbon dioxide fire extinguisher,
2. One red flag not less than 12 inches square and one red lantern for day or night use on projecting load.
3. Two wheel chocks for each vehicle or each unit of a combination of vehicles.
4. Two red flags not less than 12 inches square with standards, and three flares or three red lanterns which shall be available for immediate use in case of emergency stops.

SECTION 05 - OPERATING RULES

8318.05

A. No vehicle shall be driven at a speed greater than is reasonable and proper having due regard to weather, traffic, interseptions, width and character of the roadway, type of motor vehicle and any other existing conditions. The operator must at all times have the vehicle under such control as to be able to bring it to a complete stop within the assured clear distance ahead.

B. No vehicle shall be driven in or through any state, legal subdivision thereof, the District of Columbia or any area under the control of the Federal Government at a speed greater than that permitted by such state, legal subdivision, District of Columbia or the Federal Government.

In any event speeds will not be permitted in excess of the following:

1. In a business or residential district, twenty-five (25) miles per hour.
- *2. At other locations fifty (50) miles per hour during the daytime and forty-five (45) miles per hour at night.

C. Headlight beams will be depressed when approaching other vehicles.

D. Traffic signs and signals will be obeyed at all times.

E. Every vehicle shall be driven as far to the right

*Superseded by Presidential Proclamation setting speed limit at 35 miles per hour.

side of the traveled portion of the highway as practicable,

F. No vehicle shall be driven on a down-grade with gears in neutral or clutch disengaged.

G. No vehicle shall pass another vehicle going in the same direction on turns, curves or the crest of a hill unless there exists 500 feet of unobscured vision. This limitation shall not apply on a one-way roadway.

H. Vehicles shall not proceed on any road, street or highway in a direction opposite to that prescribed for traffic movement.

I. Every vehicle upon approaching a railroad crossing or drawbridge shall be driven at such a speed as to permit stopping before reaching the nearest track or the edge of the draw and shall proceed only if the course is clear.

J. No vehicle shall be stopped, parked or left standing on any highway or adjacent thereto in such a manner as to endanger other vehicles using such highway.

K. No vehicle shall be left unattended until after the motor has been shut off, the key removed, the parking brake securely set and all other reasonable precautions have been taken to prevent its movement.

L. All vehicles carrying loads which project more than four (4) feet beyond the vehicle will at night, or whenever atmospheric conditions are such that it is necessary, carry a red light at or near the end of the projection. At other times a red flag not less than twelve (12) inches square shall be used.

M. Employees shall not be permitted to get between a towed and towing vehicle until both vehicles have been stopped and, where necessary, wheels securely chocked.

N. Every vehicle or combination of vehicles except station wagons and passenger cars shall have posted on the side of said vehicle, in letters not less than two (2) inches high, the weight and rated capacity of such vehicle.

EXAMPLE - Wt. 4600 lbs. Rat. Cap. 8000 lbs.

O. No vehicle or combination of vehicles hauling unusually heavy loads or equipment shall be moved until the driver has been provided with the correct weights of the vehicles and load and a designated route to be followed.

P. The operators of vehicles shall make certain that the way is clear before backing or maneuvering except when directed by a qualified signalman.

Q. Operators of vehicles, except passenger cars, transporting personnel, explosives, inflammables or toxic substances shall come to a full stop at railroad crossings or drawbridges and shall not proceed until the course is

clear; providing, however, that a full stop shall not be required at a street car crossing within a business or residential district nor at a railroad grade crossing or drawbridge protected by a watchman or traffic officer on duty or by a traffic signal giving a positive indication to approaching vehicles to proceed.

R. When a bus, truck, or truck-trailer combination is disabled on the traveled portion of a highway or the shoulder adjacent thereto, except in the business or residential section of a municipality, the red flags shall be displayed during the daytime and the flares or electric lights at night or when atmospheric conditions are such that red flags are not clearly visible for at least 500 feet. One flag or flare shall be placed at least 200 feet to the front and rear of the vehicle. The third flare or electric lantern shall be placed at the traffic side of the vehicle. In connection with vehicles transporting inflammables or explosives only electric lanterns shall be used.

S. Windshields shall be maintained in such condition as to provide maximum visibility.

SECTION 06 - TRANSPORTING PERSONNEL

8318.06

A. Trucks transporting personnel shall not be operated at a speed greater than thirty (30) miles per hour.

B. Trucks being used to transport personnel shall be equipped with a seating arrangement securely anchored and a rear end gate or guard-rail.

C. Bodies of dump trucks shall be made fast to chassis while being used to transport personnel. They shall be securely fastened by a rope, chain or equivalent in addition to the normal locking device.

D. All tools and equipment shall be properly stowed and securely fastened when transported with personnel.

E. Under no circumstances shall any person be permitted to ride with arms or legs outside of truck body, in a standing position on the body, or on running boards nor seated on side fenders, cabs, cab shields, rear of truck or on the load.

F. No one shall be permitted to get on or off any vehicle while it is in motion.

G. Steps or ladders shall be provided for getting on and off trucks.

H. All vehicles transporting personnel during cold or inclement weather shall be provided with tarpaulins or other suitable enclosures.

I. No explosives, inflammables or toxic substances shall be transported in vehicles while carrying personnel.

J. No vehicle transporting personnel shall be moved until the driver has ascertained that all persons are seated and the required guard rails and rear end gates are in place.

SECTION 07 - FUELING

8318.07

A. No vehicle shall be fueled while the motor is running.

B. Fueling of vehicles shall not be permitted in the immediate vicinity of smoking, open flames or other sources of ignition.

C. Vehicles shall not be fueled inside of closed buildings.

D. All tanks, containers and fuel hoses shall be kept in metallic contact while fueling.

E. Fuel supplies shall be carried in properly constructed and mounted fuel tanks except that this provision shall not be construed to prohibit use of liquid fuel gases from a properly constructed cargo tank.

F. Filler openings for fuel tanks shall not be located inside the body or cab of any vehicle, or in such position that spills or overflow can run down on motor, exhaust pipe or battery.

G. All vehicles shall be equipped with a fuel gauge maintained in operating condition.

SECTION 08 - LOADING

8318.08

A. No vehicle shall be so loaded as to obscure the driver's view ahead or to either side or to interfere in any manner with the safe operation of such vehicle.

B. No part of the load will extend beyond the sides of the vehicle.

C. The load on every vehicle shall be properly distributed, chocked, tied down or otherwise secured in order to prevent shifting.

D. No vehicle shall be driven with a load overhanging the rear until proper warning flags or lights are in place and the driver has ascertained that required vehicle lights or reflectors are not obscured by tailboard, tailgate, or load.

(Amendment to "Safety Requirements
for Excavation, Building, Construc-
tion". 30 October 1944.)

SECTION .01

FIRE PREVENTION

8310.01

A. All construction areas and storage yards shall be burned over or otherwise cleared before lumber or other combustible materials are delivered on the site. A clear space of one hundred (100) feet around the site of storage yards will be included in the cleared area. This does not apply to trees and other natural cover retained for military purposes. Clearing operations shall be controlled in order to prevent damage to existing trees and other vegetation which are not part of the site being cleared.

B. Separation of temporary buildings:

1. The minimum space between one-story frame buildings will be forty (40) feet.
2. The minimum space between two-story frame buildings will be fifty (50) feet.
3. A group of buildings, the aggregate ground floor area of which does not exceed 2,000 square feet, will be considered as one building for the above purpose.

C. Lumber storage yards will be divided into sections containing a maximum of seven hundred fifty thousand (750,000) feet B.M. with fire breaks of one hundred (100) feet between sections. Lumber storage will be maintained at a minimum distance of one hundred (100) feet from buildings or structures. No lumber, refuse or vehicles will be left in these spaces after working hours. Parking of vehicles in fire breaks will not be permitted.

D. At least ten (10) feet clearance from buildings or structures will be maintained for piles of lumber and other materials to be used in the construction.

E. The following materials will be stored separately in detached, weatherproof buildings or shelters: acids, unslaked lime, carbide, oakum, hay and straw.

F. Storage, handling, installation and use of liquefied petroleum gases and systems will be in accordance with current standards of the National Board of Fire Underwriters for Liquefied Petroleum Gases.

G. No fires, welding, cutting, melting and other such hazardous operations shall be permitted on a project until permission has been obtained from the resident engineer or his authorized representative. Fires, open flame devices,

burning, welding, cutting, or other such operations in close proximity to combustible materials, shall not be left unattended. While danger of fire exists, an approved type fire extinguisher shall be provided at the immediate location.

H. Lanterns, acetylene lights or other open flame lighting devices will not be used in stables, garages or buildings housing flammable liquids or hay, straw, or other combustible fibrous material.

I. Lamps and lanterns will be filled only in well-ventilated rooms free from open flames, and will not be filled in oil storage buildings.

J. Temporary high voltage wires shall not be run above buildings or storage piles of combustible materials.

K. Salamanders when in use should be kept at least two feet horizontally and six feet vertically from combustible material. When used in an area inclosed by tarpaulins, they should be kept at least 10 feet from tarpaulins. Salamanders should be under constant supervision when in use.

L. All fabric or paper coverings used on storage of combustible materials or as inclosures on buildings or structures shall be flameproofed.

M. Smoking shall be prohibited in all areas where combustible materials are stored, warehouses, carpenter, paint, and repair shops, garages, service stations, and other such hazardous areas, except at locations specifically provided for such purpose and approved by the resident engineer. "No Smoking" signs shall be posted in all prohibited areas.

N. All rubbish will be cleared from buildings daily and work areas will be maintained free from accumulations of combustible debris.

O. Ashes will be regularly removed, will be deposited only in incombustible containers, and will be kept at least 2 feet from combustible walls, partitions or material.

P. Areas beneath buildings will not be used for storage of combustible material and will be regularly policed to keep them free from accumulation of debris.

SECTION .02

FIRE PROTECTION

8310.02

A. Adequate water supply shall be provided for fire fighting facilities.

B. When construction operations are suspended, a

watchman shall be employed who will make hourly rounds through areas where buildings are in place and where combustible materials are stored.

C. A first aid fire fighting device shall be provided not more than one hundred (100) feet from any point where combustible materials are stored, used or in place in buildings or structures. This device shall consist of the following:

1. For Class "A" Fires - Fires in ordinary combustible materials where the quenching and cooling effects of quantities of water or solutions containing large percentages of water are of first importance.

Soda and acid, pump tank extinguishers or water barrels and buckets.

2. For Class "B" Fires - Fires in flammable liquids, greases, etc. where blanketing effect is essential.

Foam, carbon tetrachloride, CO², dry powder pressure type extinguishers, sand buckets and scoops.

3. For Class "C" Fires - Fires in electrical equipment where the use of non-conducting extinguishing agent is of first importance.

Carbon tetrachloride, CO², dry powder pressure type extinguishers.

D. All storehouses, shops, service stations, transformer stations and other such locations shall have at least one approved type extinguisher. For floor areas exceeding twenty-five hundred (2500) square feet, at least one extinguisher shall be provided for each twenty-five hundred (2500) square feet of floor area.

E. All extinguishers and other fire fighting equipment shall be inspected, serviced and maintained in accordance with the manufacturers' instructions. Fire barrels and buckets shall be painted red, marked "Fire Only" and kept filled at all times. Anti-freeze protection shall be provided when necessary.

F. When the value of combustible materials stored or used on the site or in place in buildings or structures exceeds \$150,000, a sufficient number of mobile pumping units shall be provided and so located that no point where combustible materials are stored, used or in place in buildings or

structures shall be more than three (3) miles from such a unit.

1. Mobile pumping units shall have a rated capacity of fifty (50) G.P.M. at one hundred and twenty (120) pounds pressure and a tank of not less than five hundred (500) gallons capacity which shall be kept full at all times. Pumps shall be equipped with five hundred (500) feet of one and one-half inch hose meeting Federal Specifications for "Emergency Alternate Firehose (1½") Single Jacket" and one-half (½) inch shut off nozzle. Fifty (50) feet of suction hose with a strainer shall be provided.
2. Operators qualified to operate each mobile pumping unit shall be available twenty-four hours a day during the period of construction.
3. Names, badge number and hours of duty of fire truck operators shall be submitted to the resident engineer.

When an agreement to respond to fire alarms has been effected between a local, municipal or post fire department, located within three (3) miles of the project, such arrangement when approved by the resident engineer will be accepted in lieu of the requirement of this paragraph.

G. A necessary number of project employees shall be trained and organized into a fire brigade.

H. In the event that water tank trucks are used on the projects, they shall report to the scene of a fire in emergencies. Suitable connections shall be provided on all water tank trucks for emergency fire services.

I. Vehicles, equipment, materials and supplies will not be placed in such a manner as will obstruct access to fire hydrants, fire extinguisher or other fire fighting equipment.

J. Fire lanes to provide access to all areas will be established as construction progresses and will be maintained free of obstruction from parked vehicles and materials.

K. No fire protection equipment or device shall be made inoperative or used for other purposes.

L. A siren, telephone system or other suitable alarm arrangement shall be provided on all projects subject to approval of the resident engineer.

M. When unusual fire hazards exist or emergencies develop, additional fire protection may be required by the resident engineer.



COPY

~~CONFIDENTIAL~~

THIS DOCUMENT CONSISTS OF 3 PAGES..... COPY NO. 2..... OF 4.....
ARMY SERVICE FORCES
UNITED STATES ENGINEER OFFICE
MANHATTAN DISTRICT
OAK RIDGE, TENNESSEE

IN REPLY
REFER TO EIDMQ-5

Series B

2 May 1945.

Subject: Inspection of Decatur Area, Decatur, Illinois, 17, 18,
and 19 April 1945.

MEMORANDUM to Safety Section Files.

1. An inspection was made by the undersigned accompanied by Mr. Tom Dwyer, Safety Engineer of U.S.E.D.

2. The safety organization consists of Captain Crawford, the safety officer, and Mr. Tom Dwyer of the U.S.E.D., and one part-time employee for clerical work. The contractor has a large organization and has promised an organization chart. This should be in our hands by now. From a general viewpoint and check-up the contractor has approximately 30 employees. Management attitude is good and Major J. J. Moran is of the opinion the contractor safety set-up should be able to handle the project with Captains Crawford and Schneider as Control Officers, and the District periodic inspections. The organization problems are vague until the contractor can present his program and organization set-up.

3. The 1944 safety record showed a Frequency of 4.56, Severity, 0.28 with 4,386,041 man hours. January 1945 showed a Frequency of 3.13, Severity, 0.30 - three accidents as follows:

- a. A weld broke on a hydraulic machine and fell from the hoist, striking an employee resulting in 20 days lost-time.
- b. An employee fell from a ladder, resulting in 3 days lost-time.
- c. An employee slipped on a wet floor, resulting in 6 days lost-time.

February 1945, Frequency 4.68, Severity, 2.56 with 867,144 man hours - four accidents as follows:

- a. Fall from ladder resulting in 7 days lost-time.
- b. Employee was caught in an exposed belt and pulley resulting in a finger amputation - 200 days lost.
- c. Fall on same level, resulting in 2 days lost-time.
- d. A hook slipped on a handling operation causing a laceration, resulting in 6 days lost-time.

~~CONFIDENTIAL~~

C4

~~CONFIDENTIAL~~

March 1945, Frequency 2.19, Severity, .008 with 914,569 man hours. Two accidents as follows:

- a. Truck driver received a laceration while loading a truck resulting in 5 days lost-time.
 - b. Handling objects laceration, resulting in 3 days lost-time.
4. A serious ladder condition was found at time of inspection, in spite of two recent ladder accidents on record. The contractor has purchased a good supply of wearing apparel and other safety supplies. A very good first aid dispensary is located centrally inside the main building. A safety meeting should be held on handling materials, clearing of aisles, etc. Little is known of safety meeting program and no reports given to the Area Engineer.
5. The following recommendations were made:
1. Guard the end of the valve stem on the gas booster shed.
 2. A complete ladder program is necessary throughout the yard and plant. Many defective ladders are lying around, and many exposed to weather conditions. Others are scattered against wall behind lumber piles in front of panel boards, etc. Two recent ladder accidents are on the records.
 3. Either move or guard the garage door handles inasmuch as present position can injure a hand.
 4. All electrical wiring in sheet metal shed should be inclosed in conduit or BX.
 5. Improve general housekeeping in the sheet metal shed.
 6. Place a guard railing around all yard fire hydrants along driveways.
 7. Guard the exposed portion of saw blade of band saw located in under the table. Carpenter shop.
 8. Guard the exposed V belt shaft and pulley on the rip-saw-carpenter shop.
 9. Close the door of fuse box now blocked behind materials, dust and inflammables located in this area - carpenter shop.
 10. The fire extinguisher located near the fuse box is blocked.
 11. Remove all inflammables now piled against wood shop outside area such as sawdust, loose lumber, tarps, etc.
 12. Cover all exposed shafts and couplings on motors in machine shop area, near battery mezzanine.
 13. Fixed ladder coming down from offices on mezzanine floor machine shop should be replaced by a lift stair similar to the lower section of a fire escape. These offices, with 15 employees, are located above the ammonia operations.
 14. All portable grinder operators should wear the cup-type goggles, (one employee found using plain glasses). Special emphasis should be put on the goggle program.
 15. Keep aisles clear at all times (southwest corner of building under the conveyor system aisle is cluttered up).

~~CONFIDENTIAL~~

~~CONFIDENTIAL~~

16. Tie up all loose pressure cylinders.
17. Discontinue practice of allowing employees to work in doorways near main aisles. (Doorway F-9 and F-10 were being used by the portable crane and employees exposed to possible injury.)
18. Provide a safe method of dispensing lunch from portable carts during lunch periods. Locate a safe place for parking these carts with enough room for those being served, so as not to expose these employees to aisle traffic.
19. Several more emergency exits should be made for quick egress out of the main building in case of an emergency.
20. General housekeeping can be improved in several departments.
21. Remove hazardous scrap plates etc. from the machine shop. (At present they are in danger of falling and sharp edges protrude into the aisles.)
22. Instruct the operator of the portable crane to use care during movements of the boom and turret.
23. A gasoline compressor has been moved into the building without a safety permit.

Notes were left with Mr. Fowler of the contractor and immediate compliance promised.

6. All previous recommendations except the wiring in the sheet metal shop have been complied with.

7. No program of safety education or training is evident. The U.S.E.D. set-up is small and has not received the needed information or knowledge of the contractor organization. Some of this work is in the process of formation.

8. Upon completion of the inspection a meeting was arranged with Mr. Fowler of the contractor, and together with Mr. Andrews, another inspection was made and the items pointed out that needed first attention. All reporting is up to date and both government and military personnel accidents are followed up. Compensation cases are checked with the insurance company and the state.

9. This project should be re-inspected in June 1945.

/s/ Joseph T. Faust.
JOSEPH T. FAUST,
Safety Engineer.

~~CONFIDENTIAL~~

SAFE PRACTICES *and* HEALTH PRACTICES PAMPHLETS

Index



NATIONAL SAFETY COUNCIL, INC. • CHICAGO

Subject	Pamphlet Number
A	
Abrasive wheels, see Grinding wheels	
Absenteeism	107; H.P. 19
Accelerators—Toxic properties	Ru-1
Accident—Classification by cause	56
Accident frequency rates	21
Accident—Investigation, see Investigation of accidents	
Accident prone drivers, see Drivers and driving—Commercial—Examinations	
ACCIDENT RECORDS	21, D-4
See also 42, 93, Cem-5, D-5	
Accident reductions	42
ACCIDENT REPORTING	21, D-4
See also D-3	
Accident severity rates	21
ACCIDENT STATISTICS—GRAPHIC METHODS	21, D-5
See also 67	
ACCIDENTS AND THE ENGINEER	79
Acetaldehyde	H.P.9
Acetaldehyde aniline	Ru-1
Acetic acid	25, Chem-1, Chem-3, Ru-3; H.P.10
Acetic anhydride	Chem-1
Acetone	H.P.9, 10
Acetonitrile	H.P.9
Acetylene	23, 31, 95, Cem-4; H.P.9
Acetylene, see also Cylinders; Gases—Compressed; Welding	
Acid jugs	25, 60
ACIDS AND CAUSTICS	25
Acids—Effect on rope	6
Acids—Handling	25, 59, 60, 63
Acids—Protective clothing	14, 16, 25; H.P.10
Acids, see also Burns—Chemical; Screens—Acid; name of acid	
Acraldehyde	H.P.9
Acrolein	H.P.9
Adzes	41
Agerites	Ru-1
Agriculture, see Farmers; Threshing machines	
Air compressors	47, D-6
Air conditioning	37
Air drills	47
Air hoists, see Hoists	
Air receivers	47
Airplane fueling	52
Aisles	45, 55, 59, 99
Alban	Ru-1
Alcohols	25, Ru-3; H.P.6, 9, 10
Aldehyde ammonia	Ru-1
Aldehydes	H.P.9
Alkaline brines	Chem-1
Alkalis	25, Chem-1, Chem-3; H.P.10
Alkyl nitrites	H.P.9
Allergic diseases	H.P.4
Allylene	H.P.9
Alpha-naphthylamine	Ru-1
Aluminum	78, Ru-3
Alums	Chem-1; H.P.10
Amido compounds	H.P.9
Ammonia	25, 61, 95, Chem-1, Chem-3, Ru-3; H.P.9, 10
Ammonium carbonate	Ru-3
Ammonium nitrate	Chem-1
Ammonium sulphate	Chem-1
Amyl compounds	H.P.9
Amyl alcohol, see Alcohols	
Amylene	H.P.9
Analyses of accidents	21
Anesthetics	H.P.9

IMPORTANT
This is an index to the subject material in the Safe Practices, Special Industries and Health Practices Pamphlets.

1. Heavy face type indicates an entire pamphlet on the subject; example — **ACCIDENT REPORTING**.
2. Light face type indicates brief references to the subject in the pamphlet; example — **Absenteeism**. In such cases the numerical list of pamphlets at the end of the index should be consulted to find out general subject.
3. Safe Practices Pamphlets are referred to by number **ONLY**; Health Practices Pamphlets by the prefix **H.P.** and Special Industries Pamphlets by an abbreviation of the industry name; example—"Ru" for the Rubber Industry.
4. For numerical list of these pamphlets see last two pages.

Subject	Pamphlet Number
Anhydro-formaldehyde aniline	Ru-1
Anhydro-formaldehyde paratoluidine	Ru-1
Aniline	Ru-1; H.P.6, 9, 10
Aniline, see also Dyes	
Annealing	6, 16, 33, 98, Me-1
Anthracene	H.P.9
Anthracosis—Silicosis	H.P.4
Anthrax	PT-1
Antimony	H.P.10
Antimony sulphides	Ru-3
Antimony trichloride	Chem-1
Anti-oxidants	Ru-1
Antox	Ru-1
Aprons	16
Arc welding, see Welding—Electric	
Area of circles	78
Arm protection	16
Armatures—Sanding	ER-1
Arsenic	H.P.6, 9, 10
Arsenic trichloride	H.P.9
Arsine	H.P.9
Asbestine	Ru-3
Asbestos	Ru-3; H.P.4
Ash handling	3, 31, 46, 49, Mar-2
Asphalt	Ru-3; H.P.10
Asphyxiants	H.P.9
Astringents	H.P.10
Athlete's foot	27
Autoclaves	68
Automobiles, see Drivers and driving—Commercial; Motor Vehicles	
Automotive industry, see Motor vehicle industry	
Awards, see Banners and flags; Bonus systems; Emblems; Prizes and awards	
Axes	41
B	
Babbitting	39, Chem-4
BACK INJURIES	H.P.17
Bags, see Sacks	
BAKERY OPERATIONS	F-3
See also CE-2	
Baling presses	T-1
Balsam	Ru-3
Banners and flags	74, 100, 101
Barium	H.P.10
Barium sulphate	Ru-3
Bark mills	PT-1
Barkers	PP-1

Subject	Pamphlet Number
Barrels and pails—Fire	2'
BARRELS — HANDLING, CLEANING AND FILLING	Pet-8
Barrels—Opening	F-5
Barrels—Storage	59, CE-1, F-5
Barrels, see also Handling material; Piling material	
Barricades	PU-1
Bars, see Piling material	
Barytes, see Barium sulphate	
Basket guard for ladders, see Cages—Ladders	
Battery—Charging	D-6
Battery manufacture	H.P.1
Bearings	10
Beaters—Candy	F-2
Beaters—Cream	F-2
Beaters—Paper	PP-1
Beckton white, see Lithopone	
Beeswax	Ru-3
Belt perches	5
Belt poles	5
Belt shifters	5, 7, 39, PT-1
Belt shippers	5
BELTS—MACHINERY	7
See also 5, 31, 58	
Belts—Machinery—Static electricity	7, 31, 34, 52
Belts—Machinery, see also Hooks—Machinery belts	
Belts—Safety	25, 46, 70, 97, Cem-5, PU-3
Bending rolls	Cem-4
Bends, see Compressed air illness	
Benefit associations	H.P.5
Bentonite	Ru-3
Benzene, see Benzol	
Benzine	Ru-3; H.P.9
Benzoic acid	Chem-1
BENZOL	H.P.14
See also Ru-3; H.P.9, 10	
Benzonitrile	H.P.9
Beta naphthol	Ru-1
Beta naphthylamine	Ru-1
Bins—Cement	Cem-2, Cem-5
Bins—Dry material	46, 63, Cem-2, Cem-5
Bins—Excelsior	59
Bins—Stone	Cem-1
Black substitute, see Factice	
Blanc fixe, see Barium sulphate	
Blankets—Rubber	PU-3
BLAST FURNACES	Me-2
Blasting	Cem-1, Con-1
Blasting, see also Explosives	
Bleaching	Chem-1, PP-1, PT-1; H.P.1
Block and tackle	6
Blood poisoning, see Infections	
Blow cases—Acid	68
Blow-off valves, see Valves—Blow-off	
Blue flag, see Flags—Blue	
Boiler rooms	3, 11, 31, 46, 49, 96
Boiler shops	49, Me-3
BOILERS	3, 49, Mar-2
See also 46, 70, 96, Me-3	
Boilers—Lighting, see Furnaces—Lighting	
Boilers—Repair	3, 49, 70, Mar-2
Bolt heading machines	85
Bonus systems	74, 100, 101, D-5
Boots—Sterilizing	16
Boring machines	20, W-1
Boring mills	39, Cem-4
BOTTLING PLANTS	F-4
Box manufacture	PP-2
Box sealing machines	F-1
Boxes—Storage	54, 59, F-5
Brakes—Cranes	4
Brass chills	73
Brass—Strength	78

INDEX TO SAFE PRACTICES AND HEALTH PRACTICES PAMPHLETS

3

Heavy face type indicates an entire pamphlet on the subject. Light face type indicates a brief reference to the subject in the pamphlet.

Subject	Pamphlet Number	Subject	Pamphlet Number	Subject	Pamphlet Number
Bread slicers	CE-1, F-3	Car movers	17, 41, 54, Cem-6	Chlordinitrobenzol (Chlordinitrobenzene)	H.P. 10
Bread wrapping machines	F-3	Car retarders, see Car blockers		CHLORINE	71
BREATHING APPARATUS	64	Car shifters	41	See also 95, Chem-1, Chem-3, Ru-3;	
See also 14, 16, 23, 25, 61, 71, 91, 93, CE-2, Chem-1, F-3, M-2, Mar-1; H.P.4, 7, 9		Car wheels	ER-1	H.P. 9, 10	
Bricks—Tensile and compressive strength	78	Caramel cookers	F-2	Chloroform	61, Ru-3
Bricks, see also Buckets; Handling material		Carbide, see Calcium carbide		CHOCOLATE MANUFACTURE	F-2
Brines	Chem-1	Carbolic acid	25, Chem-1, Chem-3; H.P. 9, 10	Chrome green	Ru-3
Bromine	H.P.9, 10	Carbon bisulphide	Chem-4, Ru-3; H.P. 6, 9, 10	Chrome yellow	Ru-3
Bronze—Strength	78	Carbon black	Ru-3	Chromic acid	H.P. 10
Brown substitute, see Factice		Carbon dioxide	25, 37, 61, 95, Ru-3; H.P. 9	CHROMIUM	H. P. 1
Buckets—Bricks	70	Carbon disulphide, see Carbon bisulphide		See also Chem-3; H.P. 10	
Buckets—Sand	73	CARBON MONOXIDE	H.P. 7	Circles—Dimensions	78
Buckets—Scrap	85	See also Mar-1, Me-2; H.P. 6, 9		Circuit breakers	29
BUILDING CONSTRUCTION	Con-1	Carbon tetrachloride	24, 61, Ru-3	Cisterns—Dimensions	78
Building construction, see also Construction industry		Carbonyl acid, see Carbon dioxide		Clays and clay products	Ru-3
Bulldozers	85, Cem-4	Carboys	25, 54, 59	CLEANING AND FINISHING ROOMS	Me-1
BULLETIN BOARDS AND SCORE BOARDS	38	Carburizing	Au-1	Cleaning fluids	L-1
See also 65, 67, 100, 101, Cem-5, D-5		Carding machines	T-1, W-1	Cleanliness	27; H.P. 10
Bumpers—Cranes	4	Carliffts	D-6	Clearance—Railroad	17, 46, 48, Cem-6
Bumpers—Railroad	48, Cem-6	Carts, see Trucks		Clips for rope	26, Cem-6
Burgundy pitch	Ru-3	Carving machines	W-1	CLOTHING—PROTECTIVE	16
Burns—Cement, see Dermatitis—Cement		Case hardening	85, Au-1, Chem-6	See also 10, 23, 25, 39, 50, 59, 60, 61, 73, 76, 85, 93, 105, 107, CE-1, Chem-3, Pet-6, Pu-3, W-2; H.P. 10	
BURNS—CHEMICAL	Chem-3	Castings—Foundries	73	Clutches—Power driven apparatus	5, 8
See also 25, 60, 61		Cause classifications of accidents	21	Coal bins, see Bins—Dry material	
Burns—Electrical	29	Caustic alkalis	Chem-1, Chem-3	Coal bunkers	46, Mar-2
Burns—Eyes	Chem-3	Caustic potash	25, Chem-3, H.P. 10	Coal crushers	8, 46
Burns—Lime	25, Chem-3, PT-1	Caustic soda	25, Chem-3, Chem-4, Ru-3; H.P. 10	Coal dust	46, 78, 97; H.P. 4
Bus operators, see Drivers and driving—Commercial		CAUSTICS	25	Coal—Firing	3, 36, Mar-2
Butaldehyde	H.P.9	See also 16, Chem-3, Chem-4, F-4		COAL—HANDLING AND STORAGE	46
Butane	61, 95	Caustics, see also name of chemical		See also 17, 96, 97	
Butchers—Protective clothing	16	Celite, see Diatomaceous earth		Coal hopper grating	46, 97
Butchers, see also Packing industry		Celluloid clothing	16	Coal—Loading and unloading	46, 97
Butene	Ru-1	CEMENT BURNING	Cem-3	COAL—PULVERIZED	97
Butyl acetate	H.P.9	Cement dermatitis, see Dermatitis—Cement		See also 3, 46, Cem-3	
Butyl alcohol	H.P.9	CEMENT MILL GRINDING	Cem-2	Coal tar distillation products	H.P. 9
Butylene	H.P.9	CEMENT MILL SHOPS	Cem-4	COCOA MANUFACTURE	F-2
Butyraldehyde aniline	Ru-1	CEMENT MILL YARDS AND RAILROADS	Cem-6	See also H.P. 4	
Butyric acid	Chem-1	CEMENT ROCK QUARRYING AND CRUSHING	Cem-1	Codes, see Standards	
		CEMENT STORING, PACKING AND SHIPPING	Cem-5	Coke chutes	Pet-6
		Cement—Tensile and compressive strength	78	Cold heading machines	85
		Ceresin	Ru-3	Collars—Power driven apparatus	8
		Certificates—First Aid	83	Collecting accident records	21
		Certificates—Merit	40, 74	Colophony	Ru-3
		CHAINS—HOISTING	98	Colors—Machinery	50
		See also 6, 33, 70, 75, Cem-6, Con-1, Con-3, PP-1		COLORS—PIPING SYSTEMS	88
		Chains—Hoisting, see also Annealing		Colors—Walls	50
		CHAINS AND SPROCKETS	8	Combers	Ru-3, T-1
		Chairs	50	Commercial drivers, see Drivers and driving—Commercial	
		Chalk; see Whiting		COMMITTEES—SAFETY	72
		Change houses	27, Con-2	See also 42, 56, 77, 83, 87, 93, 101, CE-1, D-5	
		Charging boxes—Foundries	73	COMPOUNDING MATERIALS IN RUBBER INDUSTRY	Ru-1, Ru-3
		Charging machines—Foundries	73	COMPRESSED AIR ILLNESS	Con-2
		CHECKING PLANS AND SPECIFICATIONS	53	COMPRESSED AIR MACHINERY	47
		Checks—Safety	67	See also 39, Con-2, Me-3	
		CHEMICAL LABORATORIES	60	Compressed air tools	39, 47, Me-3
		CHEMICALS	25, 60,	Compressed gases, see gases—Compressed	
		Chem-1, Chem-2, Chem-3, Chem-4, Chem-5, Chem-6		Concreting	Con-1
		See also 14, 16, 39, 61, Ru-1, Ru-3; H.P. 10		CONFECTIONERY MANUFACTURE	F-2
		Chemicals, see also name of chemical		See also 68	
		Chimneys	31, 49	CONSTRUCTION INDUSTRY	Con-1, Con-2, Con-3
		Chip guards	39, Cem-4	See also 31, PU-1	
		Chippers	PP-1	CONSTRUCTION OF MACHINERY GUARDS	58
		Chipping	14, Me-3	CONTESTS	74
		Chisel bar holder	41, 70	See also 42, 67, 100, 101 D-4	
		Chisels	41	Contests, see also Campaigns	
		Chloracetic acid	Chem-1	CONTESTS—FIRST AID	83
		Chlorbenzol (Chlorbenzene)	H.P. 10	See also M-2	
				Controllers—Electrical—Cranes	4

INDEX TO SAFE PRACTICES AND HEALTH PRACTICES PAMPHLETS

Heavy face type indicates an entire pamphlet on the subject. Light face type indicates a brief reference to the subject in the pamphlet.

Subject	Pamphlet Number	Subject	Pamphlet Number	Subject	Pamphlet Number
CONVEYORS	35	Digesters	68, PP-1	ELECTRICITY—STATIC	5
See also 20, 46, 49, 59, Au-1, Au-2,		Dimethyl ketone	H.P. 9	See also 31, 32, 34, Chem-5, L-1	
Cem-2, Cem-5, F-1, F-2, F-3, F-4,		Dimethyl sulphate	H.P. 9	Electrodes	105
F-5, PP-1, W-1, W-2		Dimethylammonium dimethyl dithio-		Electrolytic cells	Chem-1
Cookers	F-1	carbamate	Ru-1	Electroplating, see Plating	
Copper cyanide, see Cyanides		Dimethylaniline	H.P. 9	ELEVATORS—FREIGHT	15
Copper—Strength	78	Dinitrobenzol	H.P. 6, 10	See also 59, CE-1, D-6, W-1	
Core making	73	Diortho-tolyl ethylene diamine	Ru-1	ELEVATORS—PASSENGER	15
Corrugators	PP-2	Diortho-tolyl guanidine	Ru-1	See also CE-1	
Cotton gin machinery	52	Diortho-tolyl thiourea	Ru-1	Emblems—No-accident	D-5
COTTON MILLS	T-1	Dip tanks, see Tanks—Dip		Embossing presses, see Presses—	
Cottonseed oil	Ru-3	Diphenyl ethylene diamine	Ru-1	Embossing	
Couplers and coupling—		Diphenyl guanidine	Ru-1	Emery	Ru-3
Railroad .. 48, 55, 73, Cem-6, RR-1		Diphenyl thiourea	Ru-1	Employees benefit associations, see	
COUPLINGS—SHAFT	8	Dipping rooms	Me-1	Benefit associations	
Court of inquiry	56	Dirty Andy	100	Employees—Meetings, see Meetings—	
Cracker manufacturing	F-3	Discipline	14, D-5	Employees	
Cranes—Locomotive		Discs—Cupola blowers	73	Employees—New, see New employees	
..... 17, 33, 46, Cem-6, Con-1, PP-1		Discs—Pressure vessels	68	Employees—Selection	39, 87, 107
CRANES—OVERHEAD		Dished heads—Contents	78	Employees—Selection, see also Drivers	
TRAVELING	4	Disinfectants	27, Mar-1; H.P. 10	and driving—Commercial—Selection	
See also 59, Cem-4, ER-1, Me-3		Dispensaries	H.P. 5, 8	Employees—Training	
Cranes—Portable	33	Dispensaries, see also First aid	 42, 67, 87, 107, Voc-1	
Crates	59	Dissolving tanks	Chem-5	Employees—Training, see also Drivers	
Creameries, see Milk bottling plants		Dithiofuroic acid	Ru-1	and driving—Commercial—Training	
Creosote	PU-4	Docks—Ore	Me-2	EMULSIONS	44
Cresol	H.P. 9; H.P. 10	Dogs	Ref-1	Engine connecting rods	9
Cresylic Acid	H.P. 10	Door saddles	11	Engine cranks	9
Crotonylene	H.P. 9	Dough brakes	F-3, F-5	Engine crossheads	9
Crowbars	41, 54	Doughnut kettles	F-3	Engine rooms	9, 31
Crucibles	73	Dovans W	Ru-1	ENGINE TESTING	Au-2
Crushing machinery	Cem-1, Cem-2	Drains—Engines	9	Engineering revision	42, 79
Crylene	Ru-1	Drill presses, see Presses—Drill		ENGINEERING TABLES	78
Cumar	Ru-3	Drills	32, 39, 76, 84, 103, Con-3	ENGINEERS—SAFETY	84
Cup for holding benzol mixtures		DRINKING WATER	27	See also 42, 79	
..... D-6; H.P. 14		See also 3, 50, Me-2; H.P. 5		Engines—Gas	31
Cupolas	73	DRIVERS AND DRIVING—		Enrobbers—Candy	F-2
Cuspidors	45	COMMERCIAL .. D-2, D-3, D-4, D-5		Entertainment	67
CUTTING OILS	44	See also F-3, Ref-1		Entertainment, see also Recreational	
See also 39; H.P. 10		Drivers and driving—Commercial—		activities	
Cutting tables—Candy	F-2	Examinations	D-2	Escalators	CE-1
Cyanamid	Chem-6; H.P. 10	DRIVERS AND DRIVING—		Essay contests	100
CYANIDES	Chem-6	COMMERCIAL—SELECTION .. D-2		Ethane	61; H.P. 9
See also 37, 85, 95, Au-1, Chem-3,		See also D-5		Ethers	H.P. 9
Chem-4, Mar-1; H.P. 10		DRIVERS AND DRIVING—		Ethyl compounds	H.P. 9
CYANOGEN COMPOUNDS	Chem-6	COMMERCIAL—TRAINING .. D-3		Ethyl alcohol, see Alcohols	
See also H.P. 9		See also D-2, D-5		Ethyl bromide	61; H.P. 9
Cylinders—Compressed gases		Drop pits	17	Ethyl chloride	61, 95; H.P. 9
23, 54, 59, 60, 61, 70, 71, 95, Cem-4,		Drugs	H.P. 9	Ethylene	95; H.P. 9
ER-1, Me-3		DRUMS—HANDLING, CLEANING		Ethylene dichloride	Ru-3
Cylindrical vessels—Dimensions	78	AND FILLING	Pet-8	Ethylidene aniline	Ru-1
D		See also 25, 52, Chem-5		Evaporating pans	68, Chem-1
Dadoing	20	DRY CLEANING	L-1	EXCAVATION WORK	Con-3
Dairies, see Milk bottling plants		See also 52		See also Cem-6, PU-1	
Definitions of standard industrial		Dry kilns	W-1	Excelsior storage	59
injury reporting system	21	Dry materials, see Bins—Dry Materials		Executives, see Management	
Degras	Ru-3	Duluth, Missabe and Iron Range Railway		EXHAUST SYSTEMS	32
Demolition of buildings	Con-1	Co. questionnaire	101	See also 20, 25, 37, 73, 79, 91, 97,	
Dental examinations	H.P. 5	Dump cars	Cem-1, Cem-6	D-6, F-3, W-1; H.P. 1, 3, 4, 7, 14	
Department stores, see Mercantile		DUST EXPLOSIONS	104	Exhaust systems, see also Ventilation	
establishments		See also 34, 52, 78, Ru-3		Exhibits .. 16, 24, 41, 67, 81, 100, 101	
Derailers	17, 48, 71	Dust removal	32, 37, 79; H.P. 4	Exits, see Fire escapes	
DERMATITIS	H.P. 10	DUSTS—HEALTH HAZARDS .. H.P. 4		EXPLOSION HAZARDS	34, 104
See also 44, Cem-5, PU-4		See also Ru-3; H.P. 20		See also 25, 46, 52, L-1	
Dermatitis—Cement	Cem-5	DYES AND DYEING	L-1	Explosion-proof motors	L-1
Dermatitis, see also Ointments		See also H.P. 10		Explosion range of gases	78
Derricks	Cem-6, Con-1, Con-3	Dyes, see also Aniline		EXPLOSIVES	28
Detectors—Gas	H.P. 7, 9	E		See also 17, 60, Cem-1, Con-2,	
Detonators, see Explosives		Education of workers, see Drivers and		Con-3; H.P. 10	
Developing solutions	H.P. 10	driving — Commercial — Training;		Explosives, see also Blasting	
DEVULCANIZERS	Ru-2	Employees—Training		Extractors	L-1
Diatomaceous earth	Ru-3	ELECTRIC EQUIPMENT	29	Eve hazards, see Eye protection	
Dichlorodifluoromethane	61, 95	See also 17, 31, 34, 39, 49, 59, 70, 76,		EYE PROTECTION	14; H.P. 1
Dichloroethylene	61; H.P. 9	78, 93, 96, Cem-4, Chem-5, L-1		See also 20, 23, 93, Cem-4, Chem-3,	
Dichlorotetrafluoroethane	61	ELECTRIC RAILWAYS	ER-1	H.P. 18	
Die blocks	85	Electric welding, see Welding		Eye protection, see also Goggles	
Dies—Handling	85	Electric wires—Capacities for		Eye service	H.P. 5
Diethyl arsine	H.P. 9	lighting	22		
Diethyl mercury	H.P. 9				

INDEX TO SAFE PRACTICES AND HEALTH PRACTICES PAMPHLETS

7

Heavy face type indicates an entire pamphlet on the subject. Light face type indicates a brief reference to the subject in the pamphlet.

Subject	Pamphlet Number	Subject	Pamphlet Number	Subject	Pamphlet Number
LOCKER ROOMS	27	Methyl alcohol, see Alcohols		Novex	Ru-1
See also 31, 73, 96, Cem-6		Methyl bromide	61; H.P. 9	NURSES IN INDUSTRY	H.P. 11
Locks—Belt shifters	5	Methyl butanate	H.P. 9	See also H.P. 5	
Locks—Machinery	70	Methyl chloride	61, 95; H.P. 9	Nut choppers	F-2
Locks—Valves...3, 70, 96, Mar-2, Me-2		Methyl ether	H.P. 9	Nut roasters	F-2
Locomotive sparks	31	Methyl-ethyl ketone	H.P. 9	Nutrition	107
Locomotives ...24, 48, 99, Cem-6, Con-3		Methyl formate	61; H.P. 9		
Looms	T-1	Methyl iodide	H.P. 9		
Lubricants and lubrication ...10, 26, 98		Methyl isonitrile	H.P. 9		
Lumber—Grading	12	Methyldichlorarsine	Chem-3	OCCUPATIONAL THERAPY ..	H.P. 16
Lumber—Storage	W-2	Methylidifluorarsine	Chem-3	Oculist service	H.P. 5
Lumber, see also Handling material—		Methylene aniline	Ru-1; H.P. 9	OFF-THE-JOB ACCIDENTS	102
Lumber		Methylene chloride	61	See also 93	
LUMBER—YARDS	W-2	Methylene dianilide	Ru-1	Oil (Fuel)	46, Cem-3
See also W-1		Methylene dichloride	H.P. 9	Oil and grease	H.P. 10
Lunch rooms	H.P. 5	Methylene diphenyl diamine	Ru-1	Oil burners	73, 96, Cem-3, Mar-2
		Methylene-ditolyl-diamine	Ru-1	Oil cans, see Oilers and oiling devices	
M		Methylene-para-toluidine	Ru-1	Oil houses	31, 34, Con-2
MACARONI MANUFACTURE	F-5	Methylene phenylene diamine	Ru-1	Oil rooms	31, 34
See also F-3		Mica	Ru-3	Oil separators	34
MACHINE SHOPS	39	MILK BOTTLING PLANTS	F-4	Oil-soaked clothing	16
See also D-6, ER-1		Milk of lime	H.P. 10	Oil substitutes, see Factice	
Machinery—Cleaning, oiling and		Milling machines	7, 39, 70, Cem-4	Oil tanks	63
repairing	9, 39, 58, 99, Au-1	MILLS—ROD	Me-4	OILERS AND OILING DEVICES ..	10
Machinery—Cleaning, oiling and		MINE RESCUE	M-2	See also 35	
repairing, see also Lubricants;		Mineral oils	Ru-3	Oils—Cutting, see Cutting oils	
Oilers and oiling devices		Mineral rubber	Ru-3	Oils, see name of oil	
Machinery—Colors, see Colors—		Mining industry ...104, M-2, H.P. 4, 9		Oilskin clothing	16
Machinery		MIXED ACID	Chem-2	Ointments	25; H.P. 1, 14
Machines—Location	11, 39	See also 25, Chem-1		Operating rooms	CE-1
Magnesium compounds ... Ru-3, H.P. 4		Mixers—Dough	F-3, F-5	Organic compounds	Ru-1
Magnesium fires	24	Molders	20, W-1	ORGANIZATION—SAFETY	42, 87
Magnet cranes	4	Monex	Ru-1	Organometallic compounds	H.P. 9
MAINTAINING INTEREST IN		Montan wax	Ru-3	Ortho-toluidine	Ru-1
SAFETY	67	Mortisers	20, W-1	Outings, see Picnics	
See also 40, 72, 80, 87, 100, 101		MOTOR BLOCK TESTING	Au-2	Ovens—Bakeries	F-3
MAINTENANCE AND REPAIR	70	MOTOR CARS—RAILROAD	RR-1	Ovens—Foundries	73
See also D-6, ER-1		Motor vehicle industry	Au-1, Au-2	Ovens—Japanning and drying.....	34
Management .42, 67, 72, 77, 93, D-5, T-1		Motor vehicles—Care and maintenance		Ovens for drying explosives	60
Manganese	H.P. 4D-5, D-6		Overalls	16
Manholes	PU-1	Motor vehicles—Static electricity ...	52	Oxalic acid	25, Chem-3; H.P. 10
Manholes, see also Hooks—Manhole		Motor vehicles, see also Drivers and		Oxide of iron, see Red Oxide	
covers		driving—Commercial; Trucks—		Oxidizers	H.P. 10
Manifolds	23	Motor vehicle		Oxygen	23, 37, 95, Cem-4
MARINE BOILERS	Mar-2	Moulding and core making	73	Oxygen, see also Cylinders—Compressed	
MARINE INDUSTRY	Mar-1, Mar-2	Mudgun	Me-2	gases; Gases—Compressed; Welding	
Marshmallow conditioning	F-2	Muriatic acid, see Hydrochloric acid		Oxynone	Ru-1
Masks—Gas, see Breathing apparatus		Mustard gas	Chem-3; H.P. 10	Ozone	H.P. 9
Match industry	H.P. 1			Ozokerite	Ru-3
MATHEMATICAL TABLES	78	N			
Mats—Standing	11, 29, 39, 50	Nailing machines	59	P	
Measurements	78	Nails—Flying	59	PACKING AND SHIPPING	59
Meat choppers	CE-1, F-1	Nails—Protruding	59, CE-1	See also CE-1, F-1, Me-3	
Meat packers, see Packing industry		Naphtha	Ru-3, H.P. 9	Packing industry	16, CE-1, F-1
Mechanical power transmission appar-		Naphthalene	Ru-3, H.P. 9	Packing industry, see also Hotels;	
atus, see Power transmission		Nappers	T-1	Knives; Restaurants	
apparatus		National Fleet Contest	D-4	Padlocks, see Locks—Machinery;	
Medals, see Emblems; Prizes and awards		Neozone	Ru-1	Locks—Valves	
Medical records	21	NEW EMPLOYEES	65	Pails, see Barrels and pails—Fire	
Medical supervision, see Health super-		See also 93		Paint spraying, see Spray coating	
vision		Nickel carbonyl	H.P. 9	Paints—Fire hazards	31, Chem-5
MEETINGS—EMPLOYEES	77, 93	Nickel salts	H.P. 10	Palm oil	Ru-3
See also 42, 65, 67, 72, 84, 102, Cem-		Nicotine	H.P. 10	PAPER AND PULP MILLS	PP-1
4, D-5		Nitrates	H.P. 10	PAPER BOX MANUFACTURE .	PP-2
Meetings—Executives	77	NITRIC ACID	Chem-2	Paper cutters—Guillotine	59, PP-2
MERCANTILE ESTABLISHMENTS		See also 25, Chem-1, Chem-3;		Paraffin oils, see Mineral oils	
.....Ce-1		H.P. 10		Para-nitroso-dimethyl-aniline	Ru-1
Mercapto-benzo-thiazole	Ru-1	Nitrobenzol (Nitrobenzene)	H.P. 9	Para-phenylene-diamine	Ru-1
Mercury	H.P. 6, 9, 10	Nitrochlorbenzol (Nitrochlorbenzene)		Para-toluidine	Ru-1
Merit rating, see Contests	H.P. 10		Paris white, see Whiting	
Metal fabrication	Me-3	Nitrogen	95; H.P. 9	Parking	17, 102
Metal—Fume fever	H.P. 4	Nitroglycerine bottle carrier	60	Pasteurizing equipment	F-4
Metal workers	H.P. 9	Nitro-hydrocarbons	H.P. 10	Patent leather finishing	PT-1
Metallic salts	Chem-3	Nitrometers	60	Pea sorting tables	F-1
METALS—STAMPING	85	Nitro-substation products	H.P. 9	Peach slicers	F-1
Metals—Strength	78	Nitrous fumes	Chem-3; H.P. 9	Pedestrian tunnels	17
METATOLUYLENE DIAMINE ...	Ru-1	Nitrous oxide	95; H.P. 9	Pentachloroethane	H.P. 9
Methane	61; H.P. 9	Noise	50	Perchloroethylene, see	
Methanol, see Alcohols		Non-freezing solutions for water ...	24	Tetrachlorethylene	
Methyl acetate	H.P. 9	Noodle cutters	F-3, F-5	Permanganates	H.P. 10

INDEX TO SAFE PRACTICES AND HEALTH PRACTICES PAMPHLETS

Heavy face type indicates an entire pamphlet on the subject. Light face type indicates a brief reference to the subject in the pamphlet.

Subject	Pamphlet Number	Subject	Pamphlet Number	Subject	Pamphlet Number
Personal protective equipment, see Breathing apparatus; Clothing-protective; Goggles; Head protection		Platforms—Boiler rooms	3	Pyrometers	10
Personnel work	84	Platforms—Cranes	4	PYROXYLIN LACQUER MANUFACTURE	Chem-5
Petrolatum	Ru-3	Platforms—Loading	Chem-1		
Petroleum ether, see Benzine		Platforms—Structural workers	Me-2	Q	
Petroleum gases	95	Plating	25, Chem-6; H.P. 1	QUARRYING	Cem-1
PETROLEUM INDUSTRY, Pet-6, Pet-8		Pledges	77	Quenching operations	Au-1
See also H.P. 10		Plumbago, see Graphite		Questionnaires	67, 100, 101
Petroleum industry, see also gasoline		Pneumatic tools, see Hammers—Pneumatic		Quilling and beaming machines	T-1
Phenex	Ru-1	Pneumoconiosis, see Dusts—Health hazards; Silicosis		Quinoidine	Ru-1
Phenol, see Carboic acid		Poisons, see Health hazards		Quizzes (Safety quizzes)	67, 100, 101
Phenyl alpha naphthylamine	Ru-1	POLES	PU-4	R	
Phenyl beta naphthylamine	Ru-1	See also PU-1		R.S.L.-A-1, etc.	Ru-1
Phenyl-hydrazine	H.P. 10	Portable electric tools, see Tools—Electric		Racks—Bars	59, Cem-4
Phenyl-tolyl-guanidine	Ru-1	POSTERS	38	Racks—Boring bits	67
Phosgene	H.P. 9	See also 93, CE-2, D-5		Racks—Chains	98
Phosphene, see Hydrogen phosphide		Posture	50	Racks—Compressed gas cylinders	Cem-4
Phosphorus	Chem-3; H.P. 9	Potassium cyanide, see Cyanide		Racks—Flask clamps	73
Photo-engravers	25	Potassium hydrate, see Caustic potash		Racks—Glove drying	PU-3
Photography	H.P. 1, 10	Potassium hydroxide, see Caustic potash		Racks—Loading	48
PHYSICAL DEFECTS	H.P. 13	Powder carrying bags	28	Racks—Storage	Cem-4, PU-3
See also D-5		POWER DEPARTMENTS	96	Racks—Tool	41, 54, 67, Cem-6
PHYSICAL EXAMINATIONS	H.P. 2	Power hammers, see Hammers—Power		Radium paint	H.P. 10
See also 50, 65, Con-2, D-5; H.P. 5, 13		Power lines	PU-1	Railings and hand-rails	2, 7, 8, 9, 12, 73, CE-1
PHYSICAL THERAPY	H.P. 16	POWER PLANTS	96	RAILROADS	RR-1
Physicians	H.P. 5	Power presses, see Presses—Power		Railroads, see also Electric railways	
Pickers	T-1	POWER TRANSMISSION APPARATUS	5, 7, 8, 9, 10	RAILROADS—INDUSTRIAL	48
Picking machines	W-1	See also 31, 39, 58, 70		See also 17, 46, 59, Cem-6	
Pickling rooms	25, Au-1, Me-1	Preserving food, see Canneries		RAMPS	2
Picnics	40, 67	Press feeding devices	18	See also 59, Con-3 D-6, F-3	
Picric acid	25, Chem-3; H.P. 10	Presses—Cold trim	85	Raped seed oil	Ru-3
Pig machines	Me-2	Presses—Drill	7, 10, 39, 58, Cem-4	Rates of accidents	21
Pike poles	41	Presses—Embossing	PT-1	RAYON MANUFACTURE	Chem-4
Pile driving	Con-3	Presses—Filter	F-1	Razor blades—Disposal	CE-2
Piling material	45, 54, 59	Presses—Horning	18	Reamers	47
Piling material—Bakeries	F-3	Presses—Hydraulic	85	Records of accidents	21
Piling material—Barrels and drums	25, 54, 59, F-5, Pet-8	Presses—Kick	18	Recreational activities	50; H.P. 5
Piling material—Bars and pipes	17, 39, 59	Presses—Platen	PP-2	Recreational activities, see also Entertainment; Picnics	
Piling material—Billets	Me-4	PRESSES—POWER	18	Red ochre	Ru-3
Piling material—Boxes and cartons	54, 59	See also 39, 45, 79, Cem-4		Red oxide	Ru-3
Piling material—Bricks	17	PRESSURE VESSELS—STEAM JACKETED VESSELS, DIGESTERS, STILLS, BLOW CASES, AUTOCLAVES, ETC.	68	Reflectors—Maintenance	22
Piling material—Cylindrical objects	59, PP-1	See also Ru-2		Refrigerants	37, 61, 78
Piling material—Foundries	17, 73	Pressure welding, see Welding		REFRIGERATION (MECHANICAL)	61
Piling material—Hotel linens	CE-2	PRIME MOVERS	9	See also F-3, F-4, Ref-2	
Piling material—Lumber	17, W-1, W-2	Printing establishments	52	Refrigeration, see also Ice	
Piling material—Pipe, see Piling material—Bars and pipes		Prizes and awards	40, 67, 74, 83, 100, 101, D-5	Regulations, see Standards	
Piling material—Poles	PU-3, PU-4	Propaldehyde	H.P. 9	Rehabilitation of injured workers	H.P. 16
Piling material—Sacks	17, 54, 59, Cem-5, F-3, F-5	Propane	61, 95; H.P. 9	Remote control apparatus	5
Pine tar	Ru-3	Propionic acid	Chem-1	REPAIR AND MAINTENANCE	70
Pine—Tensile and compressive strength	78	Propionitrile	H.P. 9	See also Cem-4, D-6, ER-1	
PIPE LINES AND TANKS	Chem-1	Propyl alcohol, see Alcohols		Report forms for accidents	21
Pipe lines, see also Pipes		Propyl compounds	H.P. 9	Resinous materials	Ru-1; H.P. 10
Piperidonium pentamethylene dithiocarbamate	Ru-1	Propylene	H.P. 9	Resistox	Ru-1
Pipes—Handling and laying	54, Chem-1	Protein precipitants, see Astringents		Respirators, see Breathing apparatus	
Pipes—Linear expansion	78	Protozoic poisons	H.P. 9	Responsibility for accidents	D-5
Piping—Engines	9	Prussian blue	Ru-3	Restaurants	CE-1, CE-2, Ref-2
Piping—Materials of construction	Chem-1	Prussic acid, see Hydrocyanic acid; Hydrogen cyanide		Restaurants, see also Bakery operations; Hotels; Knives	
PIPING SYSTEMS—IDENTIFICATION	88	Psychological tests for drivers, see Drivers and driving—Commercial—Examinations		Resuscitation	29, 93; H.P. 7
Piston clearances—Engines	9	Public accidents	CE-2, D-5, PU-1	Rewards, see Banners and flags; Bonus systems; Emblems; Prizes and awards	
Pitch	Ru-3; H.P. 9, 10	Public accidents, see also Drivers and driving—Commercial		Rheostats	29
Pits—Repair	D-6, ER-1	PUBLIC UTILITIES PU-1, PU-3, PU-4		Ring, connecting—Chains	6
Planers—Metal working	39	Pulley retainers	85	Risers, see Treads and risers	
Planers—Wood-working	7, 20, 32, W-1	Pulleys	8, 31	Rivet making machines	85
Plans, see Checking plans		Pumice	Ru-3	Rivets and riveting	41, 47, 85, Cem-4, ER-1, Me-3
Plant yards and grounds, see Yards		Punch presses, see Presses—Power		Rock drilling	Cem 1; H.P. 4
Plaques, see Prizes and awards		PURCHASING DEPARTMENTS	103	Rock dusting	104
Plaster of Paris, see Gypsum		See also 87, 93		ROD MILLS	Me-4
		Push track cars	RR-1	Rollers	54
		Pyrethrum	H.P. 10	ROPE—FIBER	6
		Pyridine	H.P. 9	See also 26, 70, Cem-6, Con-1, Con-3	

INDEX TO SAFE PRACTICES AND HEALTH PRACTICES PAMPHLETS

Heavy face type indicates an entire pamphlet on the subject. Light face type indicates a brief reference to the subject in the pamphlet.

Subject	Pamphlet Number	Subject	Pamphlet Number	Subject	Pamphlet Number
COPE—WIRE	26	Shapers—Metal working	39	SPRAY COATING	91
See also Con-1		Shapers—Wood-working	20, W-1	See also 31, 52, D-6, ER-1, Pet-8, W-1	
Rope slings	6, Con-1	Sharp-edged material—Handling	16	Sprinklers, see Fire extinguishers	
Rosin, see Colophony		Shears—Power	59, 85, Me-3	SPROCKETS AND CHAINS	8
Rottenstone, see Tripoli		Sheathes for tools	41	See also Cem-4	
Rubber cement	D-6; H.P. 14	Sheet metal	Me-3	Stabilite	Ru-1
RUBBER INDUSTRY Ru-1, Ru-2, Ru-3		Shellac	Ru-3	Stacks, see Chimneys	
See also 52, H.P. 10		Shields—Acid valves	25, Chem-1	STAIRS AND STAIRWAYS	2
RUBBER PROTECTIVE EQUIPMENT		Shields—Foundries	73	See also 93, 99, CE-1, Con-1	
.....	PU-3	Shields—Welding	105	Stake puller	PP-1
See also 16		SHIPPING ROOMS	59	STAMPING—HOT METAL	85
Rugs—Non-slip	CE-1	See also F-5, Me-3		Standard Oil Co. (Indiana)	
RULES	80	Shipping rooms, see also Handling		questionnaire	100
See also 93		material; Piling material		Standards	53, 78
Runways		Shoes	16, 39, 103	Starch	104, F-2
12, 48, 54, 59, Cem-5, Con-1, Con-3,		Shoring	Con-3	STARTING AND STOPPING	
F-3, PT-1		Shoulder protection	16	DEVICES	5
S		Shovels—Hand	41, 54	See also 8, 9, 39, 70	
Sacks—Storage		Shovels—Mechanical	Cem-6, Con-3	Static electricity, see Electricity—Static	
.....	54, 59, Cem-5, F-3, F-4, F-5	Shower baths	25, 27, 60, Chem-3, CE-2	Steam jacketed vessels	68
Safe loads, see Loads		Shredders	PP-1	Steam separators—Engines	9
Safety dogs	39	Shuttle guards	T-1	Steam shovels, see Shovels—Mechanical	
SAFETY MAN IN INDUSTRY	84	Sidewalk sheds	12	Stearic acid	Ru-3
See also 42		Sidewalk vaults	PU-1	Steel erection	Con-1
Safety meetings, see Meetings		Signals—Cranes	4, 33	STEEL INDUSTRY	
Safety quizzes	67, 100, 101	Signals—Industrial railroads	48, 71	Me-1, Me-2, Me-3, Me-4
Safety rules, see Rules		Signs—Construction work	PU-1	Steel—Tensile and compressive	
Safety stops, see Starting and		SIGNS—INDUSTRIAL	81	strength	78
stopping devices		See also 3, 80, 93, 96, Cem-1, Mar-2,		Steps, see Stairs and stairways	
SAFETY STUNTS	100, 101	PT-1		STILLS—PETROLEUM	Pet-6
See also 67		Signs—Railroads	48, Cem-6, Pet-8	See also 68	
Safety valves, see Valves—Safety		Silicon dioxide	Ru-3	Stock boxes	54
Safex	Ru-1	SILICOSIS	H.P. 20	Stockrooms, see Warehouses	
Salamanders	31, Con-1	See also H.P. 4		Stoddard solvents	L-1
Sales managers	93	Sizers—Candy	F-2	Stokers	3, 49
Salesmen	D-5	Skates	59	Stone crushing	Cem-1
Sand-blasting	Me-1	Skin affections, see Dermatitis		Stopping devices, see Starting and	
Sand cutters—Foundries	73	Skull crackers, see Drop pits		stopping devices	
Sand mills—Foundries	73	Slashers	T-1	Storage batteries	29, 55
Sand sampling cones	73	Slate flour	Ru-3	Storerooms, see Warehouses	
Sand sifters—Foundries	73	Sledge hammers, see Hammers—Sledge		Strapping	59
Sandals	16	Slings—Hoist	6, 78, Con-1, Me-1	Strength of materials	78
Sanders	20, W-1	Slitters	PP-1	Stretchers	82
Sanding tracks—Cranes	4	Slotters	39	Stunts, see Safety stunts	
SANITATION	27	Smoking	31, Mar-2	Sugar pulverizers	F-2
See also 107, W-1		Soaps and cleansing powders 27; H.P. 10		SUGGESTION SYSTEMS	40
Sanitation, see also Locker rooms;		Soapstone, see Talc		See also 67, 100	
Wash rooms		Sockets—Wire rope	26	Sulphides	H.P. 10
Sawdust	H.P. 4	Sod oil, see Degras		Sulphite mills	PP-1
Sawmills—Inspection	75	Soda ash	25, Chem-3	Sulphite pulp liquor	Chem-1
Saws—Band	20, Cem-4, W-1	Soda pulp	Chem-1	Sulphonations	Chem-1
Saws—Circular		Sodium	Chem-3; H.P. 10	Sulphur	Ru-3
.....	20, 59, 76, 78, D-6, PP-1, W-1	Sodium chloride	Chem-1	Sulphur chloride	Chem-1, Ru-3
Saws—Cracked	76	Sodium cyanide, see Cyanides		Sulphur dioxide	
Saws—Hack	39	Sodium hydrate, see Caustic soda		61, 95, Mar-1, Ru-3; H.P. 9
Saws—Hand	41	Sodium hydrosulphite	Chem-1	Sulphuric acid	
Saws—Hot	8, 85	Sodium hydroxide, see Caustic soda		25, 63, Chem-1, Chem-3, Chem-4,	
Sawyers—Protective clothing	16	Sodium hypochloride	H.P. 10	Ru-3; H.P. 9, 10	
SCAFFOLDS	12	Sodium hypochlorite	Chem-1	Sulphurous acid	Chem-1
See also 70, 78, 99, Con-1		Sodium hyposulphite	Chem-1	Sulphuryl chloride	Chem-1
Scales	59	Sodium metasilicate	H.P. 10	Supersulphur	Ru-1
Score boards, see Bulletin boards		Sodium nitrate	Chem-1	Switches—Electric	
Scoring machines	Ref-1, Ref-2	Sodium silicate	H.P. 10	29, 31, 59, 70, 76, 96, Cem-4, Chem-5	
Scrap	Me-4	Sodium sulphate	Chem-1	Switches—Railroad	48, 99, Cem-6
Screens—Acid	Chem-1	Sodium sulphide	Chem-1		
Screens—Chip	39, Cem-4	Solvents, see Flammable liquids and		T	
Screens—Foundries	73	vapors		Tackle—Lifting capacity	78
Screens—Tunnels	Con-2	Soot removal—Boilers	3	Tags—Machinery	70, 75, Ref-2
Screens—Welding	70	Spats	16	Talc	Ru-3
Screw drivers	41	SPECIFICATIONS FOR SAFETY	53	Talks—Suggestions	42, 93
Screw machines	39	Speed—Belts	7	Tallow melters	68
Selenium	Ru-3	Speed—Flywheels	9, 78	Tank cars	
Service stations, see Garages		Speed—Grinding wheels	13, 78	25, 48, 52, 71, 95, Chem-1, Chem-5
SET SCREWS	8	Speed—Grindstones	78	TANKS—CHEMICAL PLANTS Chem-1	
See also 70		Speed—Pulleys	78	See also 25, 34, 63, PP-1, H.P. 9	
Severity rates of accidents	21	Speed—Saws	20, 78, W-1	Tanks—Cleaning and repairing	
SHAFTING	8	Splices—Ropes	6	52, 63, Chem-1; H.P. 9
See also 31, 52, 58, 78, Con-2		Splitters	PP-1	Tanks—Cylindrical—Contents	78
Shaking-out operations	Me-1	Splitting machines	PT-1	Tanks—Dimensions	78
		Spontaneous ignition	34, 46, 78, 91, 104	Tanks—Dip	31, 34, Cem-4, Me-1
		Spoolers	T-1		

INDEX TO SAFE PRACTICES AND HEALTH PRACTICES PAMPHLETS

Heavy face type indicates an entire pamphlet on the subject. Light face type indicates a brief reference to the subject in the pamphlet.

Subject	Pamphlet Number	Subject	Pamphlet Number	Subject	Pamphlet Number
Tanks—Flammable liquids	25, 34, 63, Cem-3, Chem-1, Chem-5, D-6	Transfer cars	Me-2	Vulcanol	Ru-7
TANKS FOR OILS, ACIDS AND DRY MATERIALS	63	Transformers	29	Vulcone	Ru-1
Tanks—Hot water	68	Transmission lines—Static electricity	52	W	
Tanks—Rendering	68, F-1	Transmission machinery, see Power transmission apparatus		Waiters	CE-2
Tannic acid for burns	Chem-3	Treads and risers	2	Walls—Cleaning	22
Tannic acid, see also Astringents		Tree trimming	PU-1	WAREHOUSES	59
TANNING INDUSTRY	PT-1	Trenching	PU-1	See also CE-1, Cem-4, F-3, F-5, Me-3	
See also H.P. 1		Trestles	48, 99, Cem-6	Warehouses, see also Handling material; Piling material	
Tar	Chem-3; H.P. 10	Triac	Ru-1	Warpers	T-1
Tar color industry	H.P. 1	Trichloroethane	H.P. 9	Wash houses	27, Con-2
Taxicab operators, see Drivers and driving—Commercial		Trichloroethylene	H.P. 9, 10	WASH ROOMS	27
Tea tasting	H.P. 6	Trichloromethane	H.P. 9	See also 96, Cem-6; H.P. 9, 10	
Tellurium	Ru-3	Triethyl-trymethylene-triamine	Ru-1	Waste cans	31, 45
Temperatures	50, 78	Trimene	Ru-1	Watchmen	24
Tenoners	20, W-1	Trinitrophenol, see Picric acid		Water—Drinking, see Drinking water	
Termites	Cem-6	Tri-nitro-toluene	H.P. 10	Water scaler	F-3
Tests—Linemen's equipment	PU-3	Triphenylguanidine	Ru-1	Waxes	Ru-1, Ru-3; H.P. 10
Test—Ropes	26	Tripoli	Ru-3	Weights of materials	78
Tests—Rubber protective equipment	PU-3	Tripolite, see Diatomaceous earth		WELDING—ELECTRIC	105
Tetrachlorethylene	H.P. 9	Tri-sodium phosphate	H.P. 10	See also 14, 16, 39, 70, Cem-4, D-6, ER-1, Me-1, Me-3, Voc-1	
Tetrachlorethane	H.P. 9	Trolley wire guards	48	WELDING—GAS	23
Tetrachlormethane	H.P. 9	Trophies, see Prizes and awards		See also 14, 16, 39, 70, 95, 105, D-6, ER-1, Me-3	
Tetraethyl lead	H.P. 9	Truck operators, see Drivers and driving—Commercial		Westinghouse Electric & Mfg. Co. questionnaire	67
Tetra-methyl-thiuram-disulphide	Ru-1	Trucks—Compressed gas cylinders	23, 71, 95, Cem-4	Wheel dressers	13
Tetra-methyl-thiuram-monosulphide	Ru-1	Trucks—Cradle	ER-1	Wheelbarrows	17, 54, 73, Cem-6, Con-3
Tetryl	H.P. 10	Trucks—Foundries	73	White elephant	100, 101
TEXTILE INDUSTRY	T-1	TRUCKS—HAND	54	Whiting	Ru-3
See also 52; H.P. 1, 4		See also 20, 39, 59, 81, CE-1, CE-2, Cem-5, ER-1, F-2, F-3, F-5, Me-3, PP-1, Pet-8, W-1, W-2		Winches	48
Therapy, see Physical therapy		Trucks—Motor vehicle	52, 54, Cem-4, Cem-6, Con-3, PU-1, Ref-1	Wind force	78
Thermit welding, see Welding		TRUCKS—POWER	55	Winders	PP-1, T-1
Thiocarbamide	Ru-1	See also 33, 59, 103, Au-2, W-2		Wire—Current carrying capacities	
Thionex	Ru-1	Tuads	Ru-1	Wire cutters	41, PP-1
Thiophene	H.P. 9	Tumblers—Dry cleaning	L-1	WOMEN WORKERS	107
Threshing machines—Static electricity	52	Tumblers—Foundries	32, Au-1, Me-1; H.P. 4	See also 16, 73	
Tiering machines	59	TUNNELS	Con-2	Wood alcohol, see Alcohols	
Tin—Strength	78	Turntables—Railroad	48, RR-1	WOOD FURNITURE	W-1
Tires, see Handling material—Tires		Turpentine	Ru-3; H.P. 6, 10	Wood pulp	Chem-4, PP-1
Titanium dioxide	Ru-3	Twisters	T-1	Wood refuse	46
Tobacco workers	H.P. 6	U		WOOD SCAFFOLDS	12
Toeboards	2, 9, 12	Ultramarine blue	Ru-3	Wood staining	H.P. 1
Toggle presses, see Presses—Toggle		Umber	Ru-3	WOOD-WORKING PLANTS	20, W-1
TOILET ROOMS	27	Unhairing machines	PT-1	See also H.P. 1, 4	
Toluene	Ru-3; H.P. 9	Ureka	Ru-1	Wrecking, see Demolition of buildings	
Toluidine	H.P. 9	V		Wrenches	41, 70
Tolyl phenylguanidine	Ru-1	V.G.B.	Ru-1	Wrenches—Hopper car	41, 46, 48, 73
Tomato washing equipment	F-1	Vacuum cleaners	73, H.P. 4	X	
Tongs—Blacksmith	41, 54	Valves—Acid lines	25	Xanthates	Chem-4, Ru-1
Tongs—Drop hammers	85	Valves—Blow-off	3, Mar-2	X-rays	H.P. 10
Tongs—Foundries	73	Valves—Safety	3, 9, 49	Xylene	Ru-3; H.P. 9
Tongs—Hot metal plates	Cem-4	Valves—Stop	49	Y	
Tongs—Ice	Ref-1	Valves, see also Locks—Valves		YARDS	17
Tool boxes—Cranes	4	Vapors, see Flammable liquids and vapors; Fumes; Gases		See also 48, 73, Cem-6, Pet-8, W-1	
Tool handles	41, 54, 67	Vats—Chemical plants	25	Yards, see also Lumber-yards	
Tool rooms	39, 41, 70	Vats—Tanning	PT-1	Yellow ochre	Ru-3
TOOLS—ELECTRIC	76	Veneer machinery	W-1	Z	
See also 39, 70, 93, Me-3		Venetian red, see Red oxide		Zimate	Ru-1
TOOLS—HAND	41	VENTILATION	37	Zinc butyl xanthate	Ru-1
See also 39, 54, 59, 70, 76, 93, 103, CE-1, Cem-4, Cem-6, Con-3, Me-1, W-1		See also 13, 25, 32, 50, 73, 91, Chem-5		Zinc chills	23
Tools—Hand, see also Racks—Tools		Ventilation, see also Exhaust systems		Zinc chloride	Chem-1, Chem-3; H.P. 10
Tools—Machine	50, Cem-4	Vermilion	Ru-3	Zinc cyanide, see Cyanides	
TOPICS FOR SAFETY MEETINGS	93	Vibration—Machinery	11, 50	Zinc ethyl xanthate	Ru-1
Torches—Fire hazards	31	Viners	F-1	Zinc isopropyl xanthate	Ru-1
Torches—Lighting	Cem-3	Visitors	3	Zinc oxide	Ru-3; H.P. 4
Torches—Welding	23	Visors on caps	16	Zinc oxidized salt of dimethyl-dithio-carbamic acid	Ru-1
Toxic fumes, vapors and liquids, see Health hazards		VOCATIONAL TRAINING	Voc-1	Zinc salt of dithio-furoic acid	Ru-1
TRACK CARS	RR-1	Vulcanex	Ru-1	Zinc—Strength	78
Track clearances	17	VULCANIZERS	Ru-2	Zinc sulphide	Ru-3
Track skates	17	See also 68		Zyklon—B	Mar-1
Tractors, see Trucks—Power					
Trailers	55, Cem-4				
Training, see Employees—Training					

SAFE PRACTICES, SPECIAL INDUSTRIES AND HEALTH PRACTICES PAMPHLETS LISTED BY NUMBER AND TITLE

GENERAL SAFE PRACTICES PAMPHLETS

1. Ladders
2. Stairs and Ramps
3. Safe Operation of Steam Boilers
4. Overhead Traveling Cranes
5. Mechanical Power Transmission Apparatus (Part I) Starting and Stopping Devices
6. Fiber Rope
7. Mechanical Power Transmission Apparatus (Part II) Belts and Belt Guards
8. Mechanical Power Transmission Apparatus (Part III) Shafting, Coupling, Keys, Collars, Set Screws, Pulleys, Gears, Sprockets and Chains
9. Mechanical Power Transmission Apparatus (Part IV) Prime Movers (Flywheels, Cranks, Connecting Rods, Crossheads, Tail Rods, Governors)
10. Mechanical Power Transmission Apparatus (Part V) Bearings, Oilers and Oiling Devices
11. Floors and Flooring
12. Scaffolds
13. Grinding Wheels
14. Goggles
15. Elevators
16. Protective Clothing
17. Plant Yards and Grounds
18. Power Presses
19. Exits, Fire Alarms and Fire Drills
20. Woodworking Machinery and Equipment
21. Standard Industrial Injury Reporting System
22. Industrial Shop Lighting
23. Gas Welding and Flame Cutting
24. Fire Extinguishment
25. Acids and Caustics
26. Wire Rope
27. Industrial Sanitation (Drinking Water, Wash and Locker Rooms and Toilet Facilities)
28. Commercial Explosives
29. Electric Equipment in Industrial Plants
30. Discontinued
31. Fire Causes and Prevention
32. Exhaust Systems
33. Hoisting Apparatus
34. Industrial Explosion Hazards (Gases, Vapors and Flammable Liquids)
35. Conveyors
36. Fire Brigades
37. Industrial Ventilation
38. Safety Posters and Bulletin Boards
39. Machine Shops
40. Suggestion Systems
41. Hand Tools
42. Organizing a Complete Industrial Safety Program
43. Discontinued
44. The Safe Use of Cutting Oils and Emulsions
45. Industrial Housekeeping
46. Fuel Handling, Storing and Firing
47. Compressed Air Machinery and Equipment
48. Railroads in Industrial Plants
49. Construction and Equipment of Steam Boilers
50. Practical Methods for Reducing Fatigue
51. Discontinued
52. Static Electricity
53. Checking Plans and Specifications for Safety
54. Handling Material (Hand and Truck)
55. Industrial Power Trucks and Tractors
56. Investigation of Industrial Accidents
57. Discontinued
58. Mechanical Power Transmission Apparatus (Part VI) Construction of Machinery Guards
59. Warehouses and Shipping Rooms
60. Chemical Laboratories
61. Mechanical Refrigeration
62. Discontinued
63. Storage Tanks for Oils, Acids and Dry Materials
64. Respiratory Protective Equipment
65. Teaching Safety to New Employees
66. Discontinued
67. Maintaining Interest in Safety
68. Pressure Vessels—Fired and Un-fired (Part II) Steam Jacketed Vessels, Digesters, Stills, Blow Cases, Autoclaves, etc.
69. Discontinued
70. Safe Practices for Maintenance and Repair Men
71. Safe Handling of Chlorine
72. Safety Committees
73. Foundries
74. Safety Contests
75. Safety Inspections
76. Portable Electric Hand Tools
77. Safety Meetings
78. Mathematical Tables and Data for the Safety Engineer
79. Accidents and the Engineer
80. Industrial Safety Rules — Their Formulation and Use
81. Industrial Accident Prevention Signs
82. Discontinued
83. Training for First Aid and Rules for First Aid Contests
84. The Safety Man in Industry
85. Safe Practices in Forging and Hot Metal Stamping
86. Discontinued
87. Safety in the Medium-Sized Plant
88. Identification of Piping Systems
89. Discontinued
90. Discontinued
91. Spray Coating
92. Discontinued
93. Topics for Safety Meetings
94. Discontinued
95. Compressed Gases
96. Industrial Power Departments
97. Safe Operation of Pulverized Coal Systems
98. Use and Care of Hoisting Chains
99. Falls of Workers — Their Causes and Prevention
100. Safety Stunts—Part I
101. Safety Stunts—Part II
102. Off-the-Job Accidents
103. Purchasing for Safety
104. Dust Explosions
105. Electric Welding
106. Conservation of Personal Protective Equipment.
107. Women in Industry

PAMPHLETS FOR SPECIAL INDUSTRIES

- Au-1 Heat Treating
- Au-2 Safe Practices in Motor Block Testing
- Ce-1 Accident and Health Hazards in Mercantile Establishments
- Ce-2 Safety in Hotels
- Ce-3 Safety in Hospitals
- Cem-1 Cement Rock Quarrying and Crushing
- Cem-2 Raw and Finished Cement Mill Grinding
- Cem-3 Cement Burning

Members are entitled to one copy of any of the sectional pamphlets listed here when they purchase the complete set of General Safe Practices Pamphlets. Health Practices Pamphlets are NOT included in this special series.

- Cem-4 Safe Practices in Cement Mill Shops
- Cem-5 Storing, Packing and Shipping Cement
- Cem-6 Cement Mill Yards and Railroads
- Chem-1 Chemical Pipe Lines and Tanks as Causes of Accidents

- Chem-2 Fume Poisoning from Nitric and Mixed Acid
- Chem-3 Chemical Burns (Their Nature and Treatment)
- Chem-5 Pyroxylin Lacquer Manufacture
- Chem-6 Cyanide Compounds
- Con-1 Preventing Accidents in Building Construction
- Con-2 Safety and Health in Tunnel and Caisson Work
- Con-3 Safety in Excavation Work

PAMPHLETS LISTED BY NUMBER AND TITLE

CP-1 Discontinued
 D-1 Discontinued
 D-2 Selecting Drivers for Commercial Vehicles
 D-3 Training Drivers for Commercial Vehicles
 D-4 Commercial Vehicle Accident Records
 D-5 Preventing Vehicle Accidents
 D-6 Safety in Garages and Repair Shops
 ER-1 Safe Maintenance of Electric Railway Rolling Stock
 F-1 Food Preserving and Canning
 F-2 Safety in Candy, Chocolate and Cocoa Manufacture
 F-3 Safety in Bakery Operations
 F-4 Safety in Milk Bottling Plants
 F-5 Safety in Macaroni Plants
 L-1 Safety in Dry-Cleaning and Dyeing Establishments
 M-1 Discontinued

M-2 Mine Rescue Work
 Mar-1 Fumigating Ships
 Mar-2 Marine Boilers
 Mar-3 Discontinued
 Me-1 Safe Practices in Cleaning and Finishing Rooms in Foundries
 Me-2 Blast Furnaces
 Me-3 Safety in Structural and Sheet Metal Fabrication
 Me-4 Rod Mills
 PB-1 Discontinued
 PP-1 Paper and Pulp Mill Safety
 PP-2 Paper Box Manufacturing
 PT-1 Leather Tanneries
 Pet-1—5, 7 Discontinued
 Pet-6 Safe Practices in Cleaning Petroleum Stills
 Pet-8 Drums and Barrels (Handling, Cleaning and Filling)
 PU-1 Protecting Public Utility Employees on Streets and Highways
 PU-2 Discontinued

PU-3 Linemen's Rubber Protective Equipment
 PU-4 Safe Handling of Poles
 Ref-1 Safe Practices in the Delivery or Ice
 Ref-2 Safety in the Operation of Ice Processing Machines
 RR-1 Railroad Track Cars (Hand and Motor)
 Ru-1 Compounding Materials Used in the Rubber Industry, Pt. I
 Ru-2 The Safe Operation of Vulcanizers and Devulcanizers
 Ru-3 Compounding Materials Used in the Rubber Industry, Pt. II
 T-1 Cotton Mills
 Voc-1 Coordinating Safety in Industrial and Vocational Training Programs
 W-1 Safety in Wood Furniture Manufacture
 W-2 Safe Practices in Operating Commercial Lumber-yards

HEALTH PRACTICES PAMPHLETS

1. Chromium
2. Physical Examinations in Industry
3. Lead
4. Industrial Dust
5. Health Service in Industry
6. Industrial Eye Hazards

7. Carbon Monoxide
8. Caring for Injured Workers
9. Gases and Vapors
10. Skin Affections
11. Nursing Service in Industry
12. Discontinued
13. Physical Defects

14. Benzol
15. Discontinued
16. Physical Therapy in Industry
17. Back Injuries
18. Lighting and Health
19. Illness in Industry
20. Silicosis

SAFE PRACTICES SET

A complete set of the General Safe Practices Pamphlets, bound in a loose leaf binder and indexed, may be purchased by members. Each purchaser receives, automatically, a copy of every new pamphlet as issued, thus keeping the set up-to-date.

Price
\$15⁰⁰
 Price includes binder

EXTRA COPIES

of pamphlets in the Safe Practices or Health Practices series will be supplied to members at these rates:

No. of Copies	Per Copy
1 to 10.....	25c
11 to 24.....	20c
25 to 49.....	17c
50 to 99.....	14c
100 to 499.....	12c
500 to 999.....	11c
1,000 or more.....	10c

All prices F.O.B. Chicago.

HEALTH PRACTICES SET

A special series of pamphlets which serves as a practical "Handbook of Industrial Health" — valuable for quick reference purposes. Order a set now, and as new pamphlets are issued in this series they will be forwarded to you automatically.

Price
\$6⁰⁰
 Price includes binder

Chemical Laboratories

Published by National Safety Council, Inc.
20 North Wacker Drive, Chicago 6

Buildings

1. In laboratory buildings having more than one room, the places in which flash fires and explosions are likely to occur should preferably be located on the ground floor. Where the building is of fire-resistant construction, and where exits are enclosed, dangerous operations may be placed on upper floors except where local laws and regulations forbid it. In such rooms, the apparatus most likely to cause such accidents should be placed as far as possible from room exits.

2. The building should, where possible, be of fire-resistant construction. Sprinklers should be provided to supplement portable fire extinguishing equipment described in paragraphs 31 to 35. Fire walls and fire doors should be used to segregate operations where especially flammable chemicals are used. The use of glazed bricks as interior finish has been found practicable in many laboratories.

3. On each floor, unobstructed exit facilities should be provided on at least two opposite sides of the building. All exit doors should open outward and have clear wired glass inserted in the upper panel. The facilities should meet, or exceed, the requirements of local laws and regulations. Where there is an explosion hazard, several extra exits should be provided, and one or two should be of the chute or slide type, completely enclosed and leading directly to the ground.

Exhaust systems

4. The magnitude of the ventilation and exhaust problem in a laboratory will depend largely on the specific functions of the laboratory and the materials handled. For example: In small laboratories in which analyses of simple solutions are made, the only exhaust prob-

This pamphlet is one of more than 150 Safe Practices and Health Practices Pamphlets. It is a compilation of experience in accident prevention from many sources. It should not be assumed, however, that it includes every acceptable procedure in the field covered. It must not be confused with American Standard safety codes; federal laws; insurance requirements; state laws, rules and regulations; and municipal ordinances. *Additional copies of this pamphlet are available to members of the National Safety Council. Price: 35c each to members; non-member and quantity prices on request.*

lem might be the hydrogen sulphide generator, while in large industrial and research laboratories, the problem may approach that of a production department in a chemical plant. Some have only to consider non-flammable gases and vapors, while others must deal with flammable substances, gases and vapors. In any case, the problem should be given serious consideration, and the general ventilation and exhaust systems should be designed to meet the maximum requirements.

5. The general ventilation system should comply in all respects with the requirements of the state department of labor or if there are no requirements, then with those of the American Standards Association Code for Ventilation—Z25 where they apply. (This code is now being formulated by the Ventilation Code Committee of the American Standards Association.) There should be inlets and outlets at both top and bottom of the room to take care of gases and vapors lighter or heavier than air. A sufficient number of air changes per hour should be made to hold the toxic air contaminants below generally accepted maximum permissible limits. (See Safe Practices Pamphlets No. 34, "Industrial Explosion Hazards [Gases, Vapors and Flammable Liquids]," and No. 37, "Industrial Ventilation.")

6. Operations in chemical laboratories requiring local exhausts are usually protected through the use of hoods. Some take the form of cabinets having sliding or rising doors (i.e., hydrogen



Courtesy Crane Company

Figure 1. A well-designed laboratory. (See paragraphs 4 to 13.)

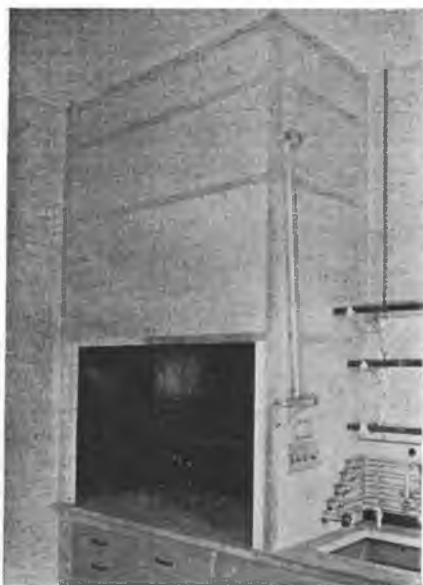

Courtesy Mellon Institute of Industrial Research

Figure 2. Cabinet provided with exhaust system. Note that water, gas, oxygen, air and vacuum lines are arranged so connections can all be made inside cabinet. (See paragraph 6.)

sulphide generators) while others rely on a properly designed exhaust hood and vents for protection. Here, again, state laws should be complied with, or the American Standards Association Code X9, "Fundamentals Relating to the Design or Operation of Exhaust Systems," should be consulted. Provision should be made for top and bottom exhausting, so both light and heavy gases and vapors will be removed. The size of ducts and the velocity of air at the hood face should be such as to keep the concentration of the various toxic gases and vapors below the maximum permissible limits. Since the diffusion velocity of gases and vapors into still air does not exceed one fpm, and natural convection not more than 25 to 50 fpm, it is safe to accept as a minimum face velocity 60 fpm. The higher the air velocity in the ducts, of course, the smaller the exhaust ducts that may be used; hence, some companies prefer a velocity as high as 200 fpm. A well designed hood is shown in Figure 2.

7. The following are additional factors that should be considered in exhaust hoods for chemical laboratories:

- a) Glazed brick tile or soapstone in the lower part of the hood, and shatter-proof glass or wired glass and metal for the upper part, are considered good materials of construction. Glass parts should be avoided where they are likely to be subject to damage from heat. The glazed brick and tile run to a height of about 5 feet.

- b) Fire-resistant materials should be used throughout the system.
- c) *Dampers should not be provided* for regulating draft. Men have been fatally poisoned through forgetting to open dampers when highly toxic gases were evolved from a reaction. The system should be designed for the maximum hazard and operated at peak efficiency at all times.
- d) Where the gases or vapors exhausted are flammable or explosive, the motor driving the fan should be explosion-proof, the fan blades of non-ferrous metal, and any lights, switches or wiring inside the hood or ducts, should be explosion-proof. The hoods, ducts, duct system, fan, motor and all other parts should be electrically grounded. Also, the connection between the hood and the duct should be of rigid metal, not canvas or other fabric tubing.
- e) Where certain substances are used, such as perchloric acid, it may be necessary to design hoods, ducts and stacks so they can be easily cleaned and washed out.

8. All ventilating and exhaust equipment should be regularly inspected, cleaned, and tested (one to three month intervals) to make certain no leaks are present, that ducts are not reduced in area by accumulations of material, and that the air velocity is at the proper level. The frequency of inspection and test will vary according to the type of work done.

9. Air conditioning should be considered where new laboratories are to be built. The many benefits of air conditioning are so familiar, and are covered so completely elsewhere, that they need not be stressed in this pamphlet. Where air conditioning is installed, it should be an integral part of the general ventilation system.

Illumination

10. The illumination of the laboratory should be of the best. If good daylight is not available, general lighting should be provided, with illumination levels of from 30 to 50 foot-candles, depending on the work done. It may be necessary, of course, to supply special local illumination where levels higher than 50 foot-candles are required. Laboratories in one-story buildings, or on the top floor of other buildings, can be provided with good natural light by means of skylights. In some laboratories, it may be necessary to install vapor-proof or explosion-proof electric equipment. Fluorescent lighting may be used, except where there is an explosion

hazard, where careful color definition is necessary, or where exacting work such as precision weighing is done. (Many parts of Safe Practices Pamphlet No. 22, "Industrial Shop Lighting," are applicable to chemical laboratories.)

Drains

11. Drain pipes should be made of such material as will resist the types of chemicals used, such as high silicon cast iron or other acid-proof materials. Lead should not be used where nitric acid may be drained. Terra cotta pipe has been successfully used in many laboratories. A cold water flush should be provided for drains where needed, except where its use would be dangerous, as where sodium is used. Where mercury is used, the drain should be arranged to trap it so the mercury can be drawn off. Oils, gasoline, carbon disulphide or other volatile liquids should not be poured down drains but should be disposed of at a safe distance from buildings by pouring them on dry sand or earth and then cautiously igniting them. (See paragraph 88.)

Laboratory tables and floors

12. Wherever Bunsen burners, electric heaters and the like are used, wooden tables should be covered with non-flammable tops, possibly with an air space between the table top and the

FIRE EXTINGUISHER CHART		Car. Disinfect.	Dry Powder
Types Chemical (Acid, Alkali, Oxidizing, etc.) Gas (Flammable, etc.) Liquid (Flammable, etc.) Solid (Flammable, etc.) Electrical (Flammable, etc.) Other	Carbon Tetrachloride	Carbon Dioxide	Bicarbonate and Other Powders
	Carbon Tetrachloride with Inert Constituents	Carbon Dioxide	Bicarbonate and Other Powders
	Carbon Tetrachloride with Inert Constituents	Carbon Dioxide	Bicarbonate and Other Powders
	Carbon Tetrachloride with Inert Constituents	Carbon Dioxide	Bicarbonate and Other Powders
	Carbon Tetrachloride with Inert Constituents	Carbon Dioxide	Bicarbonate and Other Powders
	Carbon Tetrachloride with Inert Constituents	Carbon Dioxide	Bicarbonate and Other Powders
	Carbon Tetrachloride with Inert Constituents	Carbon Dioxide	Bicarbonate and Other Powders
	Carbon Tetrachloride with Inert Constituents	Carbon Dioxide	Bicarbonate and Other Powders
	Carbon Tetrachloride with Inert Constituents	Carbon Dioxide	Bicarbonate and Other Powders
	Carbon Tetrachloride with Inert Constituents	Carbon Dioxide	Bicarbonate and Other Powders

SAFETY INSTRUCTION CARD No. 469
Revised 4-39

Figure 3. Reproduction of N.S.C. Safety Instruction Card.

protecting cover. In many laboratories, as an aid to fire prevention, the use of wood is held to a minimum by having metal tables, benches, stools, chairs and lockers. Asbestos mats are frequently used to reduce breakage of glassware. Where strong acid is used, the table should be covered with a lead or other acid-resisting coating. The furniture should be of such type as to permit efficient cleaning of the room, and the tops of hoods, lockers and cabinets should be sloped to prevent accumulations of materials on them. It is good practice to place controls for water, gas, air, vacuum and electric lines on a panel at the front of the table. This is a great convenience when a complicated set-up of apparatus is in place on the bench which would make it difficult to reach to the controls at the back of the bench. (See Figure 1.)

13. A floor covering should be provided for the laboratory, both to protect the base flooring and to lessen fatigue of employees. It should be preferably in small squares so that repairs will be easy, and may be of rubber tile or some other suitable material. Where the operations conducted in the laboratory set up a fire or explosion hazard, it may be desirable to use flooring of the conductive type and have all laboratory personnel wear conductive shoes. If mercury is used regularly, the floor should have a smooth hard finish such as terrazzo and should be sloped toward a trapped drain so the mercury can be removed. Cracks in the floors, walls or even on work tables are to be avoided since mercury will collect in them; mercury will evaporate at room temperature and a dangerous concentration may follow unless it is carefully cleaned up.

Housekeeping

14. It is essential for both safety and efficiency that the laboratory be kept neat and orderly. Floors, shelves and tables should be free from dirt and from unnecessary apparatus. Apparatus which is infrequently used should be kept in the stockroom or in cabinets which can be utilized as tables. Apparatus should be set up well back from the edge of the table; this leaves more room for work and lessens the possibility of upsetting.

15. Water, steam, air, oxygen, gas or other pipes should be painted distinctive colors so that they can be

readily recognized. Detailed suggestions are given in Safe Practices Pamphlet No. 88, "Identification of Piping Systems."

16. Cans and bins for rags are needed. Clean rags, while not as dangerous as oil-soaked rags, are readily flammable and preferably should be kept in metal bins. These bins should be provided with tight-fitting, self-closing covers. Dirty rags should be promptly thrown into approved cans provided with gravity-closing covers, which should be emptied every night. In laboratories where vegetable oils are handled, dirty rags should be burned at once, since spontaneous ignition may occur very quickly.

17. To protect janitors, there should be a separate receptacle for the disposal of all broken glassware.

18. Clothing, rags, or other flammable materials or accumulations of dust should not be permitted on steam pipes or radiators. Window sills, ledges, and stairways should not be used for storage space.

19. Spills or leaks should be cleaned up promptly. If the spilled material is flammable, every precaution should be taken to avoid igniting the material, by extinguishing all flames or electric heaters while it is being cleaned up; if it is toxic, care should be taken to evacuate personnel promptly and to return to the area only after obtaining suitable breathing equipment. (See paragraph 38.)

20. Work should be arranged so that about 15 minutes are available at the end of each day, or shift, for each man to clean up the area in which he is working.

Storage of Chemicals and Apparatus

21. Most of the following suggestions are intended to apply whether the supply of chemicals is kept in a separate storeroom or in the laboratory. The logical place for any large supply of apparatus or chemicals is in a storeroom where they can be catalogued and issued as needed. Heavy articles should be stored as near the floor as possible. Glass apparatus should be stored so that the ends do not project beyond the shelves. Glass tubing should be stored horizontally and should be kept off the floor. Shelves should be pro-

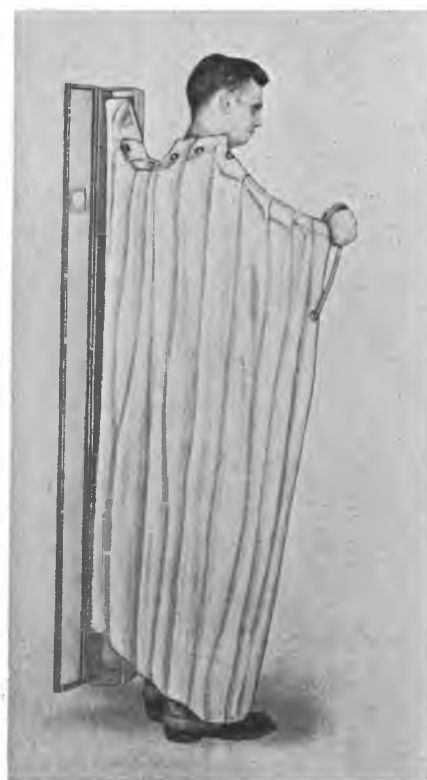

Courtesy Mine Safety Appliances Co.
Figure 4. Blanket for use in extinguishing clothing fires. Blanket may be of wool, asbestos, or glass fiber. (See paragraph 39.)

vided with copings to prevent chemicals and apparatus from sliding or rolling off. Carboys and bottles of 2½ gallon or larger capacity should be protected with wooden crates or other protective covering, regardless of their content. Wicker coverings may also be used.

22. Chemicals which might react together to give off dangerous fumes or cause fire or explosion, on accidental breakage, should be stored remote from one another.

23. Bottles of volatile liquids should not be stored near heat sources or placed in direct sunlight or near artificial light. Another hazard of sunlight is the lens effect of liquids in focusing the rays, which may cause fires and accidents. Some bottles containing volatile or explosive liquids have glass stoppers provided with a groove or vent to relieve what otherwise may become excessive internal pressure. In some laboratories, all glass vessels holding flammable liquids are encased in metal or stone-work containers sufficiently large to hold the entire contents in case the glass vessels break. In other laboratories all materials which vaporize at or near room temperatures are stored in refrigerated rooms. It is good practice,



Courtesy Hercules Powder Company
 Figure 5. Emergency shower bath provided with quick-opening valve for quickly flushing chemicals from the clothes or body. Other types have a platform-actuated valve. (See paragraph 39.)

when filling a bottle with a chemical, to allow sufficient vapor space to take care of the hydrostatic expansion of the liquid (to 131° F. [55° C.] or to the working temperature if higher).

24. Aliphatic ethers, such as ethyl and iso-propyl ethers, may be stored in metal containers provided with inhibiting agents, the presence of which should be checked from time to time, to prevent the formation of explosive peroxide. These containers should be labelled so as to call attention to the danger when handling, heating or distilling.

25. The quantity of ordinary combustible and flammable chemicals and solvents present in a laboratory should be held to the lowest practicable minimum. In particular, the amount of flammable solvent per container should be held to not more than five gallons to be used within a few days. Where use of the material is infrequent, the quantity should not exceed one gallon. Containers should be of a type approved by nationally known and recognized testing laboratories for the storage and dispensing of flammable liquids.

26. So many new chemical compounds are constantly appearing on the market that it is almost impossible for chemists to have a knowledge of the properties of all of them. Where a new compound is to be used, the manufacturer should be requested to furnish data on its properties so the chemical

can be safely stored, handled and used. Information on new compounds should be furnished to all men in the laboratory.

27. Samples of volatile liquids should not be kept on the chemist's bench but should be stored in a room as described in the following paragraph. Only samples being used should be on the laboratory benches. (See paragraph 25.)

28. All poisonous or flammable, volatile liquids and solvents should be stored in tight containers in separate rooms or compartments with an opening to the outside atmosphere for ventilation and for flooding with carbon dioxide, foam or other fire extinguishing agent. An opening in the ceiling is satisfactory in many cases, but an opening in the floor level is advantageous in rooms used for the storage of solvents generating heavier-than-air vapors. A separate, isolated, well-ventilated structure of incombustible construction is to be preferred to other storage facilities. Care should be taken, however, that air drainage from such storage spaces cannot create pockets of flammable vapors in cellars, areaways, sumps or similar locations where they might become ignited.

29. Metallic sodium and potassium must be kept in kerosene, preferably in glass and stoneware receptacles containing kerosene, and so located that they are always within sight of laboratory workers. One company makes it a practice to store containers of sodium in lead trays that are filled with sand; the sides of the trays are high enough to hold all the material in the containers if they should all break. Bottles containing fuming nitric or sulphuric acid, or mixed nitric and sulphuric acid, should be kept in incombustible and acid-resisting cupboards which are provided with lead trays. Phosphorus (white) should be stored under water in a sealed container. Phosphorus pentoxide should be stored in a tightly closed container. Previously opened cans of anhydrous aluminum chloride should be handled carefully and not be stored more than two or three weeks. Some of the other chemicals that require care in storage and handling include perchlorates, powdered magnesium, acetone peroxide, dimethyl arsine, triethyl bismuth, bleaching powders, bromates, chloracetylene, ether, diazobenzol chloride, iron sulphide, ethyl nitrite, hydro-

gen peroxide crystals, nitro compounds, nitrogen bromide, nitrogen chloride, nitrogen fluoride, potassium, potassium hydride, sodium hydride, and ethyl, isoamyl, isobutyl, methyl and propyl zinc. This list, of course, is not complete, but it is indicative of the care necessary in storing chemical compounds. (See paragraphs 111-113.)

30. Only a minimum number of employees should be kept at work in a building or room where experimental work is conducted involving unusual risks. This includes the handling of flammable liquids or gases, explosives, work at high pressures, work involving the use of compressed oxygen, liquid oxygen or liquid air, compressed or liquefied flammable gases and toxic substances or poisonous gases.

Fire Protection

31. Based on an actual survey of laboratory requirements, an adequate number of chemical fire extinguishers of various types should be provided. These should preferably be placed in the hallway. If placed in the room, they should be near the door and away from the principal fire hazard. Pails of sand with scoops are valuable under certain conditions.

32. Only vaporizing liquid or carbon dioxide extinguishers should be used on electrical fires. An electric shock might result from the use of other types of extinguishers. Soda acid, foam, or cartridge operated types of water extinguishers or hose streams should be used only on fires such as rubbish, paper, wood, rags, or other common materials. (See Figure 3 for specific uses of common hand fire extinguishers.)

33. Sodium, potassium, and magnesium fires offer a special problem in extinguishment, since the use of water, or hand fire extinguishers employing water solutions, will serve only to increase the intensity of the fire. Special extinguishing agents are available for use on such fires. Some of these extinguishing agents are in powder or flake form. (For additional information on these extinguishing agents, reference should be made to the National Safety Council Industrial Data Sheets, D-Chem 37 "Metallic Sodium," D-Gen 22 "Controlling Incendiary Bombs," and D-Me 15, "Magnesium Alloys.")

34. A room should always be ventilated thoroughly after using vaporiz-

ing liquid types of fire extinguishers, or other necessary precautions should be taken to avoid the effects that may be caused by breathing the vapors or gases produced or liberated.

35. All fire extinguishers should be tested according to a definite schedule to see that they are in good operating condition. A tag showing the date of last charge should be attached to each extinguisher. Breakable seals are available which can be used to fasten the extinguishers in place on their racks. A broken seal shows at once that the extinguisher has been used; it can then be reported for recharging.

36. Aisles and passages leading to fire extinguishers should not be obstructed. Marking lights, signs or arrows may be used to denote the position of fire extinguishers.

37. It is of little importance to provide fire extinguishing equipment if employees in the laboratory cannot use it intelligently. When testing or recharging the portable extinguishing equipment, it is well to have all employees present and, wherever possible, have them actually operate the extinguishers. This should be supplemented by periodic fire drills in which the use of fire hose can also be demonstrated. It is recommended that water not be turned on where unlined linen hose is provided. (For further details on fire extinguishment, see Safe Practices Pamphlet No. 24, "Fire Extinguishment.")

38. At least two gas masks of the all-service type should be part of the fire extinguishing equipment to enable fire fighters to cope safely and effectively with fires which evolve dangerous gases, vapors or smoke. The gas masks are sometimes serviceable for other purposes; for instance, when dangerous gases or vapors arise through accidents. The masks should be kept away from the hazard but near enough for convenient use. They should be examined and tested regularly to make certain they are always ready for use. Gas masks should not be used in high concentrations (over 2 per cent by volume) of poisonous gases nor in places where there is likely to be a deficiency of oxygen. (For detailed data, see Safe Practices Pamphlet No. 64, "Respiratory Protective Equipment.")

39. Wool or asbestos blankets should

be provided for use in clothing fires, especially in laboratories handling highly flammable liquids. Such blankets should be housed in suitable cabinets or in some other acceptable storage space so that the person whose clothing is afire can blanket himself quickly. (See Figure 4.) Another good provision for this hazard is a shower bath having a quick-opening valve so designed and installed that any person who has had chemicals spilled on him may deluge himself with water immediately. (See Figure 5.)

40. All strong oxidizing agents such as nitric acid and nitrates, permanganates, peroxides, perchlorates, chlorates and perchloric acid must be handled with great care to avoid mixture with easily oxidizable materials such as organic matters, sulphur, sulphides and others. When dry, such mixtures are explosive.

41. Chemicals containing ammonia should not be mixed with chlorine or bromine, and those containing iodine or ammonia should not be mixed with chlorides, bromides or iodides in the presence of oxidizing agents. Extremely sensitive and dangerous nitrogen trichloride, bromide, or iodide may be formed. Organic solvents such as alcohol should not be mixed with nitrates of silver or mercury; silver or mercury fulminate may be formed.

42. Where gas systems are used to supply Bunsen burners and other laboratory equipment, frequent inspections should be made to detect leaks, and all laboratory employees should report immediately the detection of the odor of escaping gas. Care should be taken to insure the presence of a warning agent in the gas supply.

43. Special precautions must be taken in laboratories where acetylene, or gas from gasoline, or propane-butane mixtures is used for Bunsen burners. Acetylene-air mixtures have a wide explosion range ($2\frac{1}{2}$ to 80 per cent). All gasoline-gas and acetylene systems should be constructed as recommended by the National Board of Fire Underwriters, who will furnish a copy of their rules to any interested persons. This information can also be obtained from the National Safety Council.

44. In the case of gasoline-gas machines, the valves in the main gas line and the air supply line should al-



Figure 6. One method of securing a compressed gas cylinder against falling. (See paragraph 49.)

ways be closed, and the tank vented, before attempting to recharge.

45. The use of flexible metal tubes from burner to gas pipe is recommended, especially where gas flames are likely to be left unattended. This eliminates the danger of rubber hose becoming ignited by contact with the flame. Copper tubing should not be used because of the danger of breakage by flexure. Lead tubing also breaks easily and it melts at a low temperature. Where hose of any kind is used, the gas should be turned off at the pipe and not at the burner. A control valve should be installed in each branch line feeding laboratory equipment.

46. Drums of gas-machine gasoline should be stored in isolated buildings protected from the heat of the sun and from artificial heat. Drums should not be opened until ready to charge, and the vapors from the operation should not be exposed to flame and sparks or hot objects. If possible, the machine should be charged early in the morning and, even then, precautions should be taken against pressure and static sparks when opening the drums. A stream of cold water will quickly cool the drums of low boiling gasoline and reduce any increased pressure caused by external heat.

47. It should be made certain that all gas burners are turned off at night. In some laboratories, one man is re-

quired to inspect all gas burners to be sure they are turned off, and then to turn off the main gas supply line outside the building at night. In other laboratories, each man is held responsible for turning off his own burner, and the final check-up by one man is simply an added precaution. The former method is preferable. In some cases, however, it may be necessary to leave apparatus, including heaters, operating at night. Where this is done, detailed instructions should be given the night attendant, or watchman, with particular attention being given to shutting down the apparatus in an emergency. Electric hot plates and heaters are considered safer than gas burners where the work is to be left unattended at night. However, red warning lights should be installed in the current supply line to indicate that the current is "on."

48. The fire hazard in handling volatile solvents may be reduced by operating inside a concrete trough provided with a drain. The trough may be located on the floor or be elevated but an exhaust hood should be provided in either case to prevent the formation of explosive or toxic concentrations. If a fire occurs, it can be more easily extinguished in the confined area.

Compressed Air Cylinders

49. Cylinders of compressed gases, such as oxygen, carbon dioxide, and sulphur dioxide, should be stored with the valve end up in racks to prevent falling. When cylinders are not in use, the shipping caps should be kept on to protect the valves. When in use, cylinders should be secured by a chain or other suitable means to keep them in an upright position. In some cases, where only small quantities of gas are used, small cylinders can be secured, or in cases where large cylinders are used, the cylinder may be kept outside the laboratory and the gas can be piped inside through pipes equipped with standard pressure reducing valves. With some gases such as sulphur dioxide, difficulty may be experienced in drawing off large amounts at one time. If this is the case, hot water (at about 140° F. [60° C.]) should be used to heat the cylinder; one should never use heat from gas burners, torches, or electric pads. (See Figure 6.)

50. When opening cylinders, one

should always stand away from the face of the reducing valve.

51. It is imperative to avoid even traces of oil on reducing valves on oxygen tanks; oil will ignite spontaneously in the presence of oxygen.

52. Cylinders or apparatus having valves with fibre seats should not be used. It is not possible to have a tight valve unless all parts are made of metal, preferably of brass. It is important, too, that the reducing valve mechanism and gage assembly for compressed gas cylinders be regularly tested by the servicing company and repaired when necessary.

53. Cylinders of liquefied gas, such as chlorine or sulphur dioxide, should preferably be stored in an isolated building. If they are stored outside, they should be securely racked and protected from the direct rays of the sun. Oxygen cylinders should be stored separate from cylinders containing flammable gases. It is preferable, too, that all cylinders containing different gases be segregated by type of gas. If cylinders are stored in the main building, they should never be stored close to the inlet of ventilating fans. (Detailed data on handling compressed gases will be found in Safe Practices Pamphlet No. 95, and in the publications of companies manufacturing compressed gases. The publications of the Compressed Gas Manufacturers Association should also be referred to.)

54. All cylinders containing highly flammable gases such as hydrogen, acetylene, propane-butane mixtures, and others should be grounded when set up for use. (See National Safety Council



Safe Practices Pamphlet No. 52, "Static Electricity.") This can be done by attaching a clip to the cylinder, connected to a wire which, in turn, is connected to the laboratory grounding system. Where no grounding is installed, it will be satisfactory to attach the grounding wire to the water pipes.

Labelling of Bottles

55. All bottles containing chemicals should be plainly labelled. A transparent tape may be used to protect original labels on bottles; it will fasten them securely and will permit the label to be easily read. Unless materials found in unlabelled bottles can be positively identified, they should be safely disposed of by a chemist.

56. In some laboratories, it is the practice to label bottles containing compounds such as cyanides with the usual skeleton and cross-bones and the word "POISON" in red capital letters at least $\frac{1}{8}$ inch high. Other chemists, however, consider that all chemicals should be considered poisonous. They believe that to label certain chemicals as poison may lead uninformed persons, who might have access to the laboratory, to believe that chemicals not so labelled are non-poisonous. In still other laboratories, instead of labelling highly toxic chemicals as poisonous, it is the practice to have bottles of a distinctive color, or having a rough outside surface, for such compounds.

57. Cleaning solutions should be



Figure 7. If the stopper of the bottle is laid on the bench as shown at the left, it may become contaminated, thereby causing fires, burns to the chemist, or other mishaps. These will be avoided if the stopper is handled as shown at the right. (See paragraph 61.)

Courtesy Travelers Insurance Co.



Figure 8. A safe method for inserting glass tubes in stoppers. Left: Bore hole in stopper; Center: Position glass tube through borer; Right: Remove borer. (See paragraph 63.)

kept in glass-stoppered bottles so labelled.

Opening Bottles

58. When bottles or other containers holding volatile liquids are opened, consideration should be given to their temperature, possible internal pressure, and corrosive nature. If there is danger that the liquid may spurt out, the operator should protect himself possibly by holding a towel over the bottle while removing the stopper. Protective goggles, face masks, aprons and rubber gloves should always be worn where there is danger of chemicals splashing.

59. Some liquids, such as liquid bromine, are received in bottles with stoppers set in cement or plaster of paris. Too often, the sealing agent and the stopper cannot be removed without breaking the bottle. The application of flame or hot water may develop enough pressure to burst the bottle, although hot water may be run on the seal if the lower part of the bottle is kept cool with cold water. The liquid bromine leaves a bad burn if spilled on the body, and is extremely poisonous. Some companies now receive liquid bromine in one to five pound glass ampoule-type containers which are easily opened by breaking off the end.

60. One company opens bottles of liquid bromine by making a slight scratch part way around the neck of the bottle with a file, and then pressing the end of a hot glass rod against the file mark; this causes the glass to crack around the neck. The liquid is then poured into another bottle and, when not in use, is stored in a refrigerator or under an exhaust hood.

61. In most cases, it is desirable, when pouring a chemical from a bottle, to hold the stopper of the bottle in the

hand. This should be done particularly in cases where the stopper, if laid on the bench, might touch another chemical and cause a dangerous reaction resulting in fire or possible burns when picking up the stopper. (See Figure 7.) Another obvious reason, of course, is the danger of contaminating the contents of the bottle by having the stopper placed on the bench.

Glass Tubing Connections

62. The ends of all glass tubing should be fire-polished. Before inserting tubing into stoppers or into rubber tubing, be sure that the hole is large enough to accommodate the glass. Moisten the tube and stopper thoroughly except when necessary to avoid moisture, as in a nitrometer set-up. Hold the stopper between the thumb and the forefinger, not in the palm of the hand, and place the stopper on the bench for a firm backing. Grasp the glass tube close to the end that is to fit into the stopper, and push the tube in with an even pressure. Do not attempt to push or pull the glass tubing from corks or stoppers that have become hardened; it is safer to cut the rubber or cork away from the glass. Care must be taken to push the tube all the way through the stopper and to make certain that the tube is free from obstructions. If the tube is not all the way through, and even though tests show no obstruction at first, the rubber stopper may swell and close the end of the tube later.

63. A safe method for putting tubes in stoppers and corks uses the stopper borer as a guide. The stopper is bored with a hollow borer and the plug is removed. The tube is then run through the hollow borer, the borer removed, leaving the tube in place. To remove tubes from stoppers or corks, the process is reversed; the borer is run in outside

the tube, the tube removed, and the borer can then be removed safely. (See Figure 8.)

Drinking Facilities

64. One or more drinking fountains should be installed. The practice of drinking from beakers is dangerous and has caused fatal accidents. The bubbler-type fountain equipped with a control valve is preferred, since it has proved to be ideal for irrigating the eyes in case of burns from an acid splash. The fountain should have a check valve to prevent high pressure at the outlet if there is a possibility of its being used for eye irrigation.

Desiccators

65. The well of all desiccators, especially those containing sulphuric acid as a drying agent, should be encased in a metal guard lined with asbestos cushions. Only "tough" heat-resisting glass desiccators should be used. (See paragraph 66.)

66. Vacuum desiccators and other glassware in which a vacuum is created should be tested before use under a higher vacuum than is normally used. Vacuum desiccators in which sulphuric acid is used should be placed in a four-mesh galvanized screen basket packed with asbestos wool or in a wooden box before evacuating. (See Figure 9.) Some companies enforce the rule that all desiccators over 8 inches in diameter should be protected by a wire mesh screen to prevent injuries from flying glass if the desiccator should collapse.

67. Solid materials of suitable desiccating efficiency should where possible be used as desiccating agents in place of sulphuric acid, because of the reduced hazard.



Courtesy Hercules Powder Co.
Figure 9. Before a vacuum desiccator is evacuated, it should be placed under a 4-mesh galvanized screen basket. As a substitute, a wood box may be used. (See paragraph 66.)

Filling Pipettes and Starting Siphons

68. Pipettes should be filled by the use of a suction bottle containing bicarbonate solution, by a hand bulb, by a suction pump or by a safety pipette filler, never by sucking the pipette with the mouth. The same equipment should be used when it is necessary to start a siphon by suction. (See Figures 10 and 11.) Water aspirating lines provided with convenient taps may also be employed. (See paragraph 12.) They should be run along the back of the bench so it will be easy to use them.

Acid Analysis

69. Sample bottles should always be carried to and from the laboratory and from place to place in the plant in special sample bottle carriers with stout handles. All large bottles (over three liters capacity) containing acid or corrosive liquids should be carried in special acid carriers such as canvas bottle jackets or in a wood or metal carrying case. (See Figure 12, 13 and 14.)

70. Tables for acid blending and for storage of samples in the laboratory before analysis should have lead tops with upturned edges to keep spilled acid from running on the floor or on the clothes of the chemist. They will also prevent sample bottles from rolling or sliding off the table.

71. Where solution bottles are placed on shelves, the shelves should not be more than shoulder high, where practicable, and the bottles should be surrounded with a strong rail or otherwise secured from falling due to ordinary vibration or minor explosions in the plant or in the laboratory.

72. Carboys which contain strong acid should be set in a carboy container. Where carboys are carried, a safety carboy carrier or truck should be used.

Nitrometer

73. A cellulose acetate face mask and protective goggles should be worn by operators using the nitrometer. It is desirable to wear a rubber apron while conducting this operation. Face masks should be tested (and dated) each three months to make certain they have not become brittle. Testing may be done by flexing the mask in opposite directions. (See Figure 15.)

74. The nitrometer should be used only by fully instructed and competent persons.

75. The lower stop-cock of the decomposition bulb should be left open after a charge is introduced until no further evolution of gas is evident.

76. If nitrometer acid is kept in a bottle fitted with a siphon or glass cock, it is imperative that the bottle be set in a strongly secured box not more than 4 feet above the floor.

Drying Samples

77. Ovens used to dry samples of explosives or highly flammable materials should have door latches that will open automatically in case of a slight positive pressure within the oven. This reduces the danger of wrecking the oven in case of an explosion. The temperature regulators of electric ovens in which explosive materials are dried should be checked at least once a week, and the surface temperature of the heating element should be as low as possible. Materials containing volatile flammable liquids should be dried only in steam ovens.

78. Ovens used to dry samples of explosives should be enclosed in substantial screen cages designed to retain missiles in the event of an explosion. (See Figure 16.) It is advisable to in-

stall a 60-mesh brass wire screen over the heating element of electric ovens used to dry explosives and highly flammable materials. These screens should fit snugly to the walls of the oven. The chemist should wear protective goggles and a face mask and should stand to one side when opening the door of an oven containing explosives or highly flammable materials.

Volatile Flammable Liquids

79. When feasible, distillation flasks should be heated over sand, in a water bath, or in a low melting point alloy-metal bath in preference to an open flame. Electricity is often used for this purpose, in which case it may be advisable to place another switch in the circuit away from the apparatus. An open flame should not be permitted in the same room with flammable liquids such as carbon disulphide, ether, petroleum ether (low boiling point), or with acetone. Explosion-proof motors, lights, switches and wiring are necessary, of course, where these low flash point solvents are used. Electrical resistance heating elements, made of non-combustible material, may offer a suitable method of heating except for the lowest flash point solvents such as carbon disulphide.

80. The practice of turning off burners and hot plates in other parts of the room and allowing them to cool before distilling solvents should be fol-



Courtesy Hercules Powder Co.
Figure 10. A suction bulb used for filling a pipette. (See paragraph 68.)

lowed, or the work should be done in separate rooms.

81. The distillation flasks should be made of tough, heat-resisting glass rather than common glass. In addition to surrounding the flask with a metal or other suitable enclosure, it is well to support the flask and stand in an iron pan of sufficient capacity to hold the contents of the flask in case of breakage. Boiling stones or beads should be used when possible, to prevent too rapid vaporization.

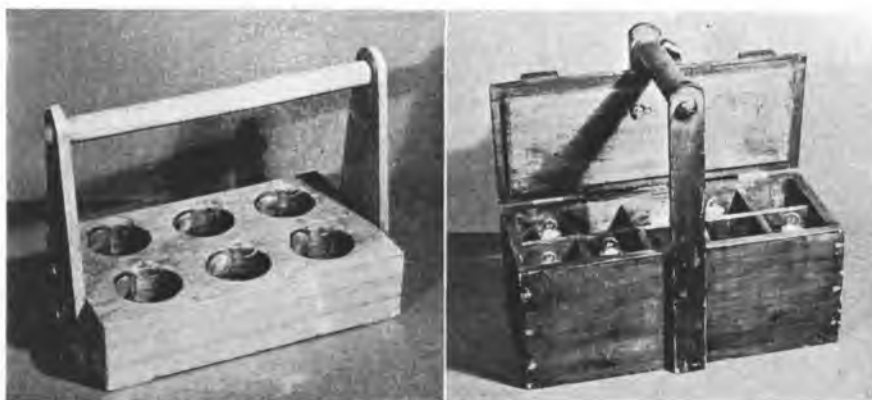

Courtesy Hercules Powder Co.

Figure 12. Two types of carrying case for sample bottles. (See paragraph 69.)

Personal Protective Equipment

82. Employees handling acids or other corrosive substances should wear rubber gloves, chemical workers' goggles, and aprons. In many laboratories it is required that protective goggles be worn at all times while at work in the laboratory. There is always a possibility of eye injury from flying glass, splashing chemicals, and other hazards. If work is being done in which poisonous or irritating gases, fumes, vapors and dusts are likely to be breathed into the lungs, U. S. Bureau of Mines approved respirators, gas masks or other protective breathing equipment should be worn. Protection against occupational skin irritants may be afforded by synthetic resin films or fabrics coated with such films, in the form of hoods, sleeves, aprons or cover-alls. (See Public Health Report, June 28, 1940, Volume 55, Number 26, pages 1158-1163.) (Details

concerning the safe use of acids and caustics are found in Safe Practices Pamphlet No. 25. The subject of goggles is covered in Safe Practices Pamphlet No. 14. See also No. 16, "Protective Clothing" and No. 64, "Respiratory Protective Equipment.") (See Figure 17.)

83. Safety shields constructed of shatter-proof glass or heavy wire mesh screening should be placed around all operations, preferably fastened in place, where there is a possibility of rupture of the apparatus. It may be necessary, in some cases, to illuminate the operation, and where this is done, if flammable liquids are used, the wiring and lights should be explosion-proof. Such enclosures should be used even though the chemist is provided with personal protective equipment such as goggles, face shields, and heavy aprons, since there is always the chance that persons working near him, and not so protected, will be injured. (See Figure 18.)

Pressure Work

84. Autoclave or other high pressure work, or any experiment requiring the use of poisonous gases or those that may be classified as dangerous, should not be carried on in the main laboratory building unless authorized by the chief chemist. Every new use for an autoclave or other pressure vessel should have the approval of the maintenance engineer, who should reach his decision after consideration by, and suggestions from, the chief chemist and the safety engineer.

85. All unfired pressured vessels which are put into use should, in every case, conform in design and fabrication to either the A.P.I. or the A.S.M.E. code, depending on their use. They

should be inspected and tested periodically. (See Safe Practices Pamphlet No. 68, "Pressure Vessels.")

86. Plugs or other fittings from pressure vessels should not be disconnected until it is certain that the pressure has been released.

87. All gages used for high pressure gas, water, steam or air service (i.e., 500 pounds per square inch and over) should be of a design that will give adequate protection for the work and should be approved by the maintenance engineer and the chief chemist for the work. Such design should include extra heavy construction, vented backs, plastic instead of glass faces, or efficient guards. Gages should be calibrated regularly on dead weight testers.

Disposal of Refuse

88. Acids and strong alkalis should be poured into sinks while flushing with water. Such materials should not be put in refuse jars. Volatile liquids should not be poured into the sink because of the possibility of the formation of gas pockets in the pipe. Scrap sodium and potassium should be destroyed by slowly adding them to alcohol, not by placing them in water. There are certain chemicals such as sodium peroxide, potassium peroxide, metallic sodium, barium peroxide and others which react violently with water. These and others should be neutralized before being disposed of.

89. Refuse should be collected at the close of the day's work or oftener, if necessary, and should not be allowed to accumulate. Dangerous waste chemicals should be destroyed by the chemists who understand the hazards—not by the janitors or laboratory wash boys.



Courtesy Hercules Powder Co.

Figure 11. Water-aspirating line for filling pipette. (See paragraph 68.)



Courtesy Westinghouse Electric & Mfg. Co.
 Figure 13. Well-designed container for small quantities of acid. This consists of a gallon jug which is set in a metal pail and then surrounded with asphalt compound. A stopper should be provided for the jug and a cover for the metal pail. (See paragraph 69.)

First Aid

90. Laboratory workers, like other company employees, should go to the doctor or to the first aid room for the treatment of all injuries, no matter how slight. Injuries should be treated in the laboratory only in emergency cases, as suggested in the following paragraphs.

91. The laboratory should preferably be equipped with a safety shower for use in case of acid burns. (See Figure 5.) However, in lieu of this, one water spigot may be fitted with a large rubber tube, so that a heavy stream of water can be directed on the body in case of burns. In case of a burn from fuming sulphuric acid, it is suggested that the surplus acid be wiped off, if possible, before applying water; otherwise the heat developed might make the burn more severe. The first consideration in case of acid burns is immediate attention and plenty of water. Prolonged irrigation is also recommended for strong caustic burns. (See Industrial Safety Series Pamphlet No. Chem-3, "Chemical Burns [Their Nature and Treatment]," for a complete discussion of first aid for chemical burns.)

92. Most doctors advise against the use of neutralizing agents in case of chemical burns. After the chemical has been washed off with plenty of water, the burn may be covered with any suitable protection, preferably a water-soluble jelly. This will avoid the necessity of removing grease when further treatment is given by the doctor. Chemical burns to the eye may be extremely serious unless the chemicals are washed out very carefully with a gentle

stream of water. Cold compresses may be used to decrease the pain. Chemical burns, no matter how slight, should always be referred to a physician.

93. In laboratories where certain poisonous substances may be swallowed accidentally, suitable antidotes should be maintained under the supervision of a specially qualified and designated individual. However, all laboratory workers should be thoroughly familiar with the procedures to be followed in emergencies.

94. In some laboratories, power driven machinery, such as drill presses, pulverizing hammers and rolls, dry and wet grinding pans, and other special machinery, is used. Belts, gears and other dangerous moving parts should be protected as recommended in Safe Practices Pamphlet No. 58, "Construction of Machinery Guards." When working around moving machinery, employees should not wear laboratory coats or other loose clothing that might be caught in the machine.

95. The non-current-carrying parts of electric equipment should be connected to ground. For details on the safe use of electricity, see Safe Practices Pamphlet No. 29, "Electric Equipment in Industrial Plants."

96. Electric equipment, such as heaters, on which liquid has been spilled should not be used again until it has been properly cleaned and dried. Extension cords on all laboratory equip-

ment should have acid-resistant and waterproof insulation.

97. When it is necessary to use a mechanical stirring device for a flammable solution, the stirrer should be actuated by a water or air motor, or an explosion-proof electric motor.

98. When oil or metal baths are used for high temperature heating, special care must be taken to prevent water or other liquids from dropping into the hot bath. The steam formed when this occurs will violently scatter the heating medium, possibly causing severe burns or even fire. All condenser connections should be securely fastened when used near such baths. When salt baths are used, it is especially important to prevent carbonaceous material from falling into the bath in order to avoid violent fire.

99. Broken or cracked glassware should never be used.

100. All mercury, flammable liquids or other chemicals should be removed from glassware before it is sent to the glassblower or washer.

101. All glassware to be used for pressure work should be approved by the chief chemist or safety engineer. Glassware with flat surfaces, except desiccators, should not be placed under vacuum.

102. When Dewar flasks are being filled with dry ice and acetone, goggles and a face mask should be worn. Dewar flasks should be cooled slowly, using only a small amount of dry ice and acetone, or liquid nitrogen; rapid cooling may cause collapse.



Figure 14. Canvas jackets for carrying acid bottles. (See paragraph 69.)

103. When picking up a beaker, fingers should be placed around the outside, not over the rim.

104. Testing chemical compounds by smelling should be done cautiously. Serious illness and even death have been caused by this practice where cyanide compounds, arsine and other highly toxic compounds were being tested by smell.

105. Any reaction which may give off nitrous fumes should be handled very carefully because of the high toxicity of such fumes. All reactions should be carried out under the exhaust hood. If accidental spillage of nitric acid on organic matter occurs, the spill should be neutralized at once and employees should leave the laboratory until all danger of fumes has disappeared.

106. In mixing liquids in a confined system, the possibility of spurting from the vessel because of heat of solution should be considered. Test tubes, beakers and flasks should be pointed away from the face when pouring liquid into them or when they are being heated. Goggles and a face mask should be worn.

107. Flasks and beakers larger than one liter should not be heated by direct flame because of the danger of breakage. Large flasks or beakers should be heated by partial immersion in a bath, by external or internal application of steam or by electric jackets. Flasks of 3 liters' capacity or over should be supported at the bottom when heated, not suspended by the neck.



Figure 15. Nitrometer mask. (See paragraph 73.)

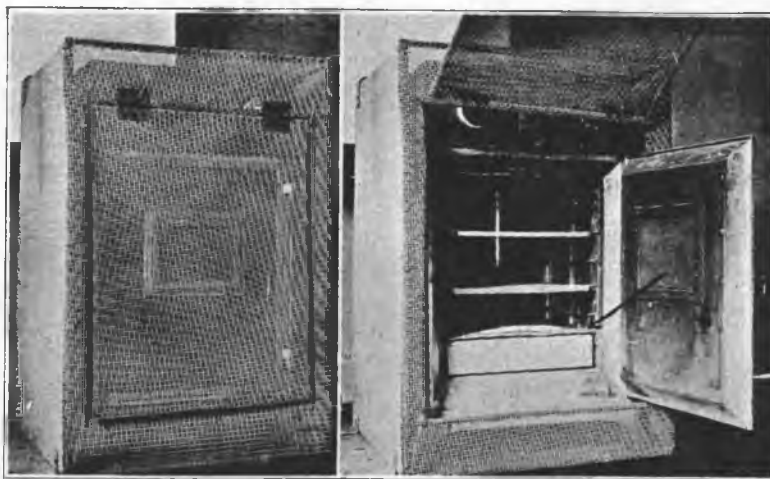

Figure 16. A substantial screen cage placed around a constant-temperature electric oven used to dry samples of explosives. (See paragraph 78.)

108. It is recommended that a well-ventilated room, away from chemical fumes be provided for men to calculate results and do other paper work.

109. Smoking in laboratories may be dangerous from the standpoint of fire and explosion or from contamination of the smoking materials with poisonous chemicals.

110. Where considerable quantities of mercury, lead or other toxic substances are handled, chemists and other laboratory workers should be required to change their clothes and bathe before leaving for home.

111. Chlorates and perchlorates are dangerous because of the quantity of oxygen they liberate when heated and because they form explosive mixtures with sugar, charcoal, shellacs, sulphur, starch, sawdust sweepings, dust or most other organic materials. Explosive mixtures are also formed with sulphuric acid, potassium cyanide, phosphorous and antimony. Any of these mixtures may be exploded by friction, heat, shock or detonation. Where perchlorates are contaminated by oil or grease, they will detonate on shock.

112. Small quantities of chlorates, perchlorates and chloric acid may be kept in the laboratory in reagent bottles closed with soft rubber stoppers. They should be kept in a cool place, away from other chemicals and heat sources. Large quantities should be kept in a special storeroom in the same manner that explosives are stored. (See Industrial Data Sheet D. Chem. 8, "Safe Handling of Chlorates and Perchlorates"

and Safe Practices Pamphlet 28, "Commercial Explosives.")

113. Chemists should use only the smallest practicable quantities of chlorates and perchlorates, or other compounds which readily liberate oxygen. Non-ferrous spatulas should be used for mixing, and grinding should be done very carefully, wet if possible. Goggles and face shields should invariably be worn even though the quantities handled are very small. If amounts greater than 5 to 10 cc are being mixed or ground, a steel barrier may be used to protect the chemist against injury if the mixture should explode. Properly placed mirrors will enable the chemist to view his work while he is protected by the barrier.

114. Although care should be used in handling all reagents, it is well that a few common chemical compounds, that should be handled with special care, be emphasized. The list is not complete, but is intended merely to serve as a guide:

Skin and eye irritants

Acetic acid, glacial
 Acetic anhydride*
 Acetylacetone
 Aldol
 Amines (all)
 Ammonium hydroxide (concentrated)*
 Aniline
 Barium peroxide
 Butanol
 N-Butylamine
 Butylidene acetone
 Butyl maleimide*
 Chloroacetic acid*
 Chlorinated solvents
 Crotonaldehyde
 Dimethylfuran
 Dimethyl sulphate*
 Dinitroaniline



Courtesy E. I. duPont de Nemours & Co.
 Figure 17. One type of goggles used by chemical laboratory workers. Some chemists prefer goggles with side shields. (See paragraph 82.)

Dinitrochlorbenzene
 Dinitrophenol
 Ethyl chloracetate*
 Ethylene chlorhydrin
 Ethylenediamine*
 Ethyleneimine*
 2-Ethyl-3-Propylacrolein
 Ethylene oxide*
 Ethylidene acetone*
 Formaldehyde (40%)*
 Glycol diformate
 Hydrochloric acid (concentrated)
 Hydrofluoric acid
 Hydrogen peroxide (over 3% in strength)
 Maleic anhydride*
 Methyl silicate*
 Nitric acid
 Phenol
 Phenylhydrazine
 Phosphorous pentachloride
 Phosphorous oxychloride
 Phosphorous trichloride
 Potassium hydroxide
 Propyleneimine*
 Sodium hydroxide* }
 Sodium peroxide
 Sulphuric acid (concentrated)*
 Sulphuric acid (fuming)*
 Thiodiglycol†
 Tin-organic compounds*

*Compound is known to have caused injuries to the human eye in laboratories.

†Thiodiglycol is relatively harmless as such, but easily forms mustard gas on contact with hydrochloric acid. Waste materials from these compounds should be disposed of and the bottles should be thoroughly water-rinsed by the chemist working with them, to make certain that some other person will not attempt to rinse the bottles with hydrochloric acid before they are clean.

Toxic vapors

Ammonia
 Aniline†
 Arsine*
 Benzene
 Bromine
 Cadmium
 Carbon dioxide
 Carbon disulphide*
 Carbon monoxide
 Carbon tetrachloride
 Chlorine
 Chloroform*
 Crotonaldehyde
 Dichlorethyl ether
 Diketene
 Dimethyl sulphate
 Dioxan
 Ethylene chlorhydrin*
 Ethylene dichloride
 Ethylene oxide
 Formaldehyde
 Hydrogen chloride
 Hydrogen cyanide*
 Hydrogen fluoride
 Hydrogen sulphide
 Lead
 Mercury
 Methanol
 Methyl "Cellosolve" solvent
 Methyl silicate
 Nitric acid (fuming)
 Nitrobenzene
 Nitrogen oxides
 Ozone
 Phosgene*
 Phosphine
 Sulphur dioxide
 Toluene
 Trichlorethylene
 Vinyl chloride

*Especially dangerous.

†Aniline spilled on clothing may cause serious or even fatal poisoning if not removed promptly.

Internal poisons

Acids, mineral
 Alkalis, caustic
 Ammonia
 Aniline*
 Antimony compounds
 Barium compounds
 Copper compounds
 Cyanides†
 Dichlorisopropyl ether
 Diethylene glycol
 Di-n-hexylamine
 Ethylene diamine
 Ethylene imine
 Ethylene oxide
 Fluorides
 Glycol diformate
 Iodine
 Isophorone
 Lead compounds
 Methanol

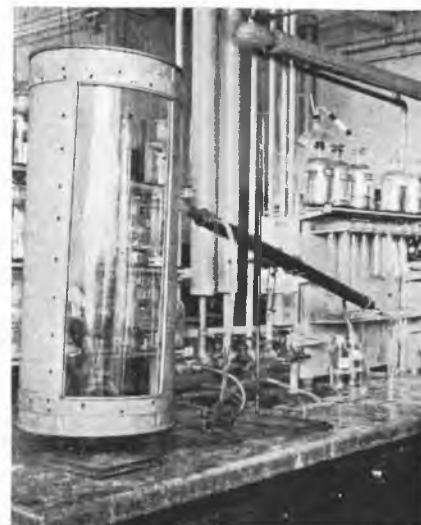

Courtesy Agfa Anso
 Figure 18. Well-designed protective equipment for a distillation operation. (See paragraph 83.)

Mercury compounds*
 Nitrobenzene*
 Oxalic acid, oxalates
 Phenol
 Phosphorous compounds*
 Permanganates
 Propylene chlorhydrin
 Propylene imine
 Pyridine
 Selenium compounds
 Silver compounds
 Tin compounds
 Triglycol dichloride
 Zinc compounds

*Especially dangerous.

†Cyanides can be absorbed in toxic quantities through open cuts. (See Industrial Safety Series Pamphlet No. Chem-6, "Cyanide Compounds.")

ACKNOWLEDGMENT

This pamphlet was revised by a special committee of which John S. Shaw, director of safety, Hercules Powder Company, was chairman and John M. Roche, Director, Industrial Division, National Safety Council, was secretary. Grateful acknowledgment is made to the members of the special committee, the Safe Practices Pamphlet Committee, the Health Practices Pamphlet Committee and to various individuals who participated in this work. The final draft of this pamphlet was approved by the Executive Committee of the National Safety Council.

A. S. A.
A 13—1928

Recommended American Practice

Scheme for the Identification of Piping Systems

A Systematic Plan Employing Color and Other Kinds
of Markings Based on Fundamental Principles

Approved by
American Standards Association
November, 1928

Sponsor Organizations
National Safety Council
108 East Ohio Street, Chicago, Ill.
The American Society of Mechanical Engineers
29 West 39th Street, New York, N. Y.

Recommended American Practice

Scheme for the Identification of Piping Systems

A Systematic Plan Employing Color and Other Kinds
of Markings Based on Fundamental Principles

Approved by
American Standards Association
November, 1928

Sponsor Organizations
National Safety Council
108 East Ohio Street, Chicago, Ill.
The American Society of Mechanical Engineers
29 West 39th Street, New York, N. Y.

Foreword

THE organization of the Sectional Committee on the Identification of Piping Systems took place on June 14, 1922, under the procedure of the American Standards Association. The National Safety Council and The American Society of Mechanical Engineers are Joint Sponsors for this project, and the Committee consists of 33 members representing 28 technical societies and industrial organizations. The work of the Committee was divided among the following sub-committees; 1, Sub-Committee on Identification by Colors; 2, Sub-Committee on Identification by Markings Other Than Color; 3, Sub-Committee on Classification. The Executive Committee consists of the Chairman and Secretary of the Sectional Committee and the Chairmen of the Three Sub-Committees. Report of Sub-Committee No. 1 was submitted in December, 1923; that of Sub-Committee No. 2 in October, 1924; and that of Sub-Committee No. 3 in December, 1924. The Executive Committee then constituted itself with Messrs. E. J. Cole and M. R. Paul as an Editing Committee which combined the reports of the three Sub-Committees into this unified scheme.

For the purpose of setting up an historical background it should be recorded that in June, 1908, Mr. William H. Bryan of St. Louis, presented a comprehensive article on the "Identification of Power House Piping by Colors" before The American Society of Mechanical Engineers (A.S.M.E. Proceedings, vol. 30, pp. 773-782). The interest which this paper created prompted the Council to organize a committee whose report appears in the Transactions of the Society, vol. 33 (1911), p. 17. The next year at the 25th meeting of the Association of Edison Illuminating Companies held at Briar Cliff Manor August 31, 1909, Mr. J. P. Sparrow read a brief paper on "Standard Colors for Power Station Piping." This paper was printed but not published.

In the November 29, 1920, issue of "National Safety News," an article was published on the great need for a color scheme for pipe lines. The article closed with a request for information and comment on the present identification systems in factories and power plants. Replies to this request were helpful in working up the new scheme.

In 1921 a number of papers and articles were published. The Prime Movers Committee of the National Electric Light Association submitted a report containing a table showing the color codes used by various companies. The A.S.M.E. printed an article in "Mechanical Engineering" on "Standard Methods of Identification of Fluids Conveyed by Pipes in Power Houses and Industrial Plants" (July, 1921). In July of that same year the U. S. Navy Department issued as part of its specifications for Power-Plant Apparatus and Piping, a section giving a color scheme for the painting of pipes. This was a revision of a chart originally published in the "Blue Jackets' Manual" in 1917.

All of these papers, reports, and publications were studied by the Sectional Committee on the Identification of Piping Systems in developing the scheme for the identification of piping systems which is now presented for approval as a "Recommended American Practice."

Sectional Committee on the Identification of Piping Systems

Officers of the Sectional Committee

Amos S. Hebble, *Chairman*, Superintending Engineer, Southern Pacific Steamship Lines, Pier 49, North River, New York, N. Y., representing the Society of Naval Architects and Marine Engineers.

Ira G. Hoagland, *Secretary*, Secretary, National Automatic Sprinkler Assn., 80 Maiden Lane, New York, N. Y., representing the National Automatic Sprinkler Association and Fire Protection Assn.

November, 1928

Price 50 cents

Personnel of Sectional Committee

- Ross P. Anderson**, Technologist, American Petroleum Institute, 250 Park Avenue, New York, N. Y., representing the American Petroleum Institute.
- Harry E. Bates**, Assistant to Chief Operating Engineer, The Peoples Gas Light & Coke Co., 122 Michigan Avenue, Chicago, Ill., representing the American Gas Association.
- L. W. Bates**, Project Manager, Power Plant Section, Bureau of Yards & Docks, Navy Department, Washington, D. C., representing U. S. Navy Department.
- Rudolph E. Bruckner**, Sales, National Gauge and Equipment Co., 11 Wilbur Street, Long Island City, N. Y., representing the International Acetylene Association.
- William L. Bunker**, The Texas Co., 929 S. Broadway, Los Angeles, California, representing the Society of Naval Architects and Marine Engineers.
- Everett J. Cole**, Chief Chemist, Hilo Varnish Corp., Marcy and Flushing Avenues, Brooklyn, N. Y., representing the National Varnish Manufacturers Association.
- Bureau of Construction and Repair, U. S. Navy Department**, Washington, D. C., representing U. S. Navy Department.
- I. J. Fairchild**, Mechanical Engineer, Bureau of Standards, Washington, D. C., representing the Bureau of Standards.
- H. E. Farrer**, Secretary, Standards Committee, American Institute of Electrical Engineers, 29 West 39th Street, New York, N. Y., representing American Institute of Electrical Engineers.
- Crosby Field**, Vice-President, Brillo Manufacturing Co., Inc., 205 Water Street, Brooklyn, N. Y., representing the American Institute of Chemical Engineers.
- H. A. Gardner**, Educational Bureau, Scientific Section, Paint Manufacturers Association, 1845 B Street, N. W., Washington, D. C., representing the National Paint, Oil and Varnish Association.
- Theo. M. Gevrenze** (alternate for W. S. Morrison), Chief Engineer, The Cuneo Eastern Press, Inc., Spring and MacDougal Streets, New York, N. Y., representing The American Society of Mechanical Engineers.
- P. H. Glatfelter**, Secretary, P. H. Glatfelter Co., Spring Grove, Pa., representing Technical Association of the Pulp and Paper Industry.
- Amos S. Hebble**, Superintending Engineer, Southern Pacific Steamship Lines, Pier 49, North River, New York, N. Y., representing the Society of Naval Architects and Marine Engineers.
- James G. Higgins**, 317 81st Street, Brooklyn, N. Y., representing the U. S. Department of Labor.
- Ira G. Hoagland**, Secretary, National Automatic Sprinkler Association, 80 Maiden Lane, New York, N. Y., representing the National Automatic Sprinkler Assn. and National Fire Protection Assn.
- F. C. Hodgkinson**, American Circular Lophm Co., 90 West Street, New York, N. Y., representing the National Electrical Manufacturers Association.
- J. J. Howe** (alternate for L. W. Bates), Electrical Engineer, Navy Yard, New York, N. Y., representing U. S. Navy Dept.
- Frank P. Ingalls**, Chief Chemist, John W. Masury & Sons Co., 44 Jay Street, Brooklyn, N. Y., representing the Paint Manufacturers Association.
- LeRoy E. Kern** (alternate for R. C. Taggart), Technical Secretary, Scientific Research Department of the American Institute of Architects, 19 West 44th Street, New York, N. Y., representing the Office of State Architects.
- S. H. Kershaw**, Safety Engineer, National Safety Council, 108 East Ohio Street, Chicago, Illinois, representing the National Safety Council.
- Willis Lawrence**, Mechanical Engineer, Interborough Rapid Transit Co., Power Station, 59th Street and North River, New York, N. Y., representing the National Association of Stationary Engineers.
- Alexander Maxwell** (alternate for A. L. Penniman), Engineer, National Electric Light Association, 420 Lexington Ave., New York, N. Y., representing the National Electric Light Association.

- William S. Morrison**, Assistant Mechanical Engineer, New York Edison Co., 124 East 15th Street, New York, N. Y., representing The American Society of Mechanical Engineers.
- Arthur K. Ohmes**, Consulting Engineer, Tenney & Ohmes, 101 Park Avenue, New York, N. Y., representing the American Society of Heating and Ventilating Engineers.
- M. Rea Paul**, Consulting Colorist, National Lead Co., Laboratory, 105 York Street, Brooklyn, N. Y., Member at Large.
- Ross S. Peck**, Engineer, Dwight P. Robinson Co., Inc., Grand Central Palace, New York, N. Y., representing The American Society of Mechanical Engrs.
- A. L. Penniman**, Superintendent Steam Station, Consolidated Gas and Electric Light and Power Co., Lexington & Liberty Streets, Baltimore, Maryland, representing the National Electric Light Association.
- Andrew A. Pfeiffer**, Asbestos Construction Company, Inc., 451 West 28th Street, New York, N. Y., representing the Pipe Covering Contractors Association.
- G. E. Sanford**, Safety Engineer, General Electric Co., Schenectady, New York, representing the American Society of Safety Engineers.
- Henry S. Smith**, Chief Engineer, Prest-O-Lite Co., Inc., 30 West 42nd Street, New York, N. Y., representing the Compressed Gas Manufacturers Association.
- William W. Smith**, Chief Engineer, Federal Shipbuilding and Dry Dock Co., Kearney, N. J., Member at Large.
- Frank N. Speller**, Metallurgical Engineer, National Tube Co., 1810 Frick Building, Pittsburgh, Pa., representing the American Society of Refrigerating Engineers.
- R. C. Taggart**, N. Y. State Department of Architecture, The Capitol, Albany, N. Y., representing the office of the State Architect.
- H. P. Weaver**, General Manager, Independence Bureau, 137 South Fifth Street, Philadelphia, Pa., representing the National Safety Council.
- Richard A. Wolff**, President, Wolff & Munier, Inc., 222 East 41st Street, New York, N. Y., representing the Heating and Piping Contractors National Association.

Sub-Committee on Identification by Colors

F. P. INGALLS, <i>Chairman</i>	H. A. GARDNER
I. J. FAIRCHILD	M. R. PAUL
C. FIELD	E. J. COLE

Sub-Committee on Identification by Markings Other Than Color

W. S. MORRISON, <i>Chairman</i>	W. LAWRENCE
T. M. GEVRENZE	R. C. TAGGART
J. J. HOWE	

Sub-Committee on Classification

CROSBY FIELD, <i>Chairman</i>	H. P. WEAVER
I. J. FAIRCHILD	A. L. PENNIMAN

Executive Committee

A. S. HEBBLE, <i>Chairman</i>	F. P. INGALLS
CROSBY FIELD	W. S. MORRISON
I. G. HOAGLAND	

Editing Committee

I. G. HOAGLAND, <i>Chairman</i>	F. P. INGALLS
E. J. COLE	W. S. MORRISON
CROSBY FIELD	M. R. PAUL
A. S. HEBBLE	

Introduction

Purposes of Standardization. Color schemes for the identification of piping systems have been developed in the past by a large number of industrial plants and organizations of various kinds. In 1909 The Association of Edison Illuminating Companies published a report on "Standard Colors for Power Station Piping." Likewise in 1911 The American Society of Mechanical Engineers published and distributed broadly a scheme which was specially applicable to power plants. Later in 1920 the American Society of Heating and Ventilating Engineers published "Color Schemes for Distinguishing Plant Piping." Some years previous to 1917 the U. S. Navy, Bureau of Engineering, developed and placed in use on board ship a color scheme for piping. Later in 1919 a different scheme was published by the Bureau of Yards and Docks for use on land stations. In June, 1921, the Prime Movers Committee of the National Electric Light Association published a table showing some of the color schemes then in use and pointed out the great need for a standard scheme. The Bureau of Standards in 1921 adopted the U. S. Navy, Bureau of Engineering, standard.

Generally speaking, the standards arrived at in individual cases have given satisfaction to those using them. They suffer, however, from a complete lack of uniformity and in particular there is no universal differentiation of designation between pipes containing materials safe to handle, and those unsafe. As a result of these conditions, spontaneity of action in time of emergency is lost, particularly when outside agencies, such as fire departments, are called in to assist. In addition there is at present a confusion in the minds of those who change employment from one plant to another. Many mills and plants, desirous of securing the advantages of an identification scheme, have not installed one because of the fact that no generally accepted standard was available.

Requirements for a Standard Scheme for Identification of Piping Systems. The principal requirements for a standard scheme for the identification of piping systems are: (a) distinguishability, (b) flexibility, (c) inclusiveness, (d) simplicity, (e) practicality, and (f) rationality. The proposed standard

scheme meets as many of these requirements as the present state of the art will permit. It is therefore the hope of the Committee that Industry as a whole will gradually adopt it, even though it is recognized that the supplanting of present systems and the adoption of the new one must of necessity be accomplished gradually. It will be noted that this standard scheme, while establishing a universal standard leaves the maximum freedom of action to each branch of industry.

Inclusiveness with Flexibility. The inclusion of all existing systems at present in use is made readily possible with minimum change under this scheme. Its first and principal requirement is that the pipes in each system shall be so colored as to designate exactly which of the five major classes of fluids are being conveyed by the system.

This Scheme provides that the color may be applied over the entire length of the piping system or in bands eight to ten inches wide near valves and at other important places. The use of bands permits of identification by color, even though all the pipes of a given layout are given uniform treatment for purposes of illumination or decorative appearance.

Where it is desired to identify more exactly the nature of the fluids in a given piping system, this may be accomplished by (a) the addition of one or more stripes of color at the edges of the band or by (b) stenciled letters, words or figures on the band. For example: in a plant having several safe materials, there would be several pipes having the dominant color or color band of green, and superimposed on these green bands on one piping system might be a stripe of red, on another a stripe of yellow, another a stripe of blue, etc., the color of the secondary stripe having lost its main classification significance under this scheme. If the selected system had included legends instead of stripes, then in the example given above there would be superimposed upon each green band the stenciled name of the material conveyed by that particular pipe, or an identification mark of some kind.

Advantages of Proposed System. The use of multi-colored schemes in the past has

conveyed the general impression that there are numerous colors from which to select and upon which to build a system of identification so wide in scope as to embrace all materials necessary in any plant. In reality, however, colors which show a sufficient difference to be readily recognized under adverse conditions, are so few as to make such a scheme difficult to handle. Further, there are comparatively few pigments which may be considered sufficiently permanent to stand up satisfactorily under all

conditions of use and exposure. Most of these are high-priced and not in all instances, readily available.

The present need is for a clear, concise scheme which will quickly establish in the minds of plant employees, the danger or safety of materials carried in a given pipe. Then by the use of secondary color or legend the scheme may be expanded in a given plant or industry to permit the complete identification of the materials in the piping systems.

Scheme for the Identification of Piping Systems

Object and Scope

1 The Scheme is intended to harmonize all specifications for the identification of materials conveyed in piping systems and is intended to form an acceptable basis for a universal scheme.

2 This Scheme has been limited to the identification of piping systems in industrial plants and power plants, not including pipes buried in the ground and electric conduits.

Definitions

3 **Piping Systems.** For the purpose of this Scheme, piping systems shall include in addition to pipes of any kind: fittings, valves, and pipe coverings. Supports, brackets, or other accessories are specifically excluded from applications of this standard. Pipes are defined as conduits for the transport of gases, liquids, semi-liquids, or plastics, but not solids carried in air or gas.

4 **Fire-Protection, Materials, and Equipment.** This classification includes sprinkler systems and other fire-fighting equipment.

5 **Dangerous Materials.** These materials are those which are in themselves hazardous to life or property by virtue of being easily ignited or productive of poisonous gases or are in themselves poisonous. They include materials that are known ordinarily as fire producers and explosives.

6 **Safe Materials.** These products are those involving no hazard in their handling and no extraordinarily high value. A workman in approaching a piping system to make

repairs will accordingly run no undue risks in breaking into a pipe bearing a safe material, even though that material had not been emptied by previous arrangement.

7 **Protective Materials.** Under this class fall materials which are piped through plants for the express purposes of being available to prevent or minimize the hazard of the dangerous materials above mentioned. Thus, a plant may have certain special gases which are antidotes to poison fumes, piped through its shops for the express purpose of release in case of danger.

8 **Extra Valuable Materials.** These might be classified with the group of the safe materials above mentioned, but where these products have a very high value, it is preferable to give them a separate major classification.

Method of Identification

9 "At conspicuous places throughout a piping system color bands shall be painted on the pipes to designate to which one of the five main classes its contents belongs. If desired the entire length of the piping system may be painted the main classification color. (See paragraph 13.)

10 Further, the actual contents of a piping system may be indicated by, preferably, a stenciled legend giving the name of the contents in full or abbreviated form. These legends shall be placed on the colored bands. The identification scheme may be extended by the use of colored strips placed at the edges of the colored bands.

11 The bands, legends, and stripes shall be

placed at intervals throughout the piping system, preferably adjacent to valves and fittings to ensure ready recognition during operation, repairs and at times of emergency."

Main Classification by Color

12 This part of the Scheme is intended to identify the main classes into which the materials in the piping systems belong. It establishes a basic fundamental principle applicable to all schemes for identifying piping systems and is intended to designate the pipe contents as belonging to a specific class of materials that are safe, dangerous or otherwise, depending on local conditions. The inclusion of all existing systems at present in use is made readily possible with minimum change by the adoption of the following color classification.

13 All piping systems are classified according to the character of material carried. Especially in an emergency the quick recognition of the contents of a piping system is of paramount importance. For this purpose, each piping system is classified, by the nature of its contents, into the following classifications:

CLASS	COLOR
F—Fire-protection equipment.....	Red
D—Dangerous materials.....	Yellow (or orange)
S—Safe materials.....	Green (or the achromatic colors, white, black, gray, or aluminum)

and, when required

P—Protective materials.....	Bright blue
V—Extra valuable materials.....	Deep purple

14 The above colors have been chosen to identify the main classification because they are readily distinguishable one from another. Reference to Appendix B will show in addition the relation of the colors chosen to each other and to the color circle on which the color arrangement has been based.

15 Red has been assigned to fire-protection equipment because of long established custom. Yellow and orange have been assigned to dangerous materials because of all the saturated chromatic colors these have the highest coefficient of reflection under white light and can therefore be more readily recognized under the poorest conditions of illumination. Further,

yellow is the traditional color of the quarantine flag and has been adopted as the caution signal for railroads and road traffic. The assignment of the other three colors follows in natural order.

Detailed Instructions for Working Out a Standard Identification Scheme¹

16 List all materials carried in the pipes of the system or systems.

17 Assign each of these materials to one of the five main classes: Safe products (S), Dangerous materials (D), Protective materials (P), Extra valuable materials (V), and Fire-protection equipment (F).

18 Group the materials assigned to each class for the purpose of facilitating the selection of sub-class markings.

19 Choose between the alternative methods of (a) color bands or (b) complete color painting.

20 Assign a legend or color stripe to each material listed under each main classification.

21 Refer to Appendix C and select the five colored paints which will identify the main classes and the paints to be used for the stripes if the use of stripes has been decided upon in place of legends.

22 No type of paint or other suitably colored coating is excluded. The selection of coatings comes under the jurisdiction of the supervising engineer or person in authority and may be made to meet the diverse requirements of each case. All that the scheme requires is that the dominant hue of the band shall fall unmistakably within one or the other of the five spectral regions.

23 Colors which have a total reflective value too low to permit ready differentiation at minimum illumination are excluded. Median gray, which from the physiological or visual standpoint is situated about halfway between white and black, reflects approximately 25 per cent of the incident standard white light and is near the permissible limit of reflective value for poor illumination. The permissible limit of reflective value is provisionally established at 19 per cent.

24 An ordinary hand flash lamp when held by an operator at the reading distance may be used as the arbitrary measure of minimum illumination.

¹ NOTE. The Sectional Committee on the Identification of Piping Systems has created a permanent organization to enable it to assist those firms and individuals who desire to consult it preparatory to the installation of this standard scheme. Address all communications to one or the other of the sponsor bodies.

Appendix

Classification of Materials Carried in Pipes

For the purpose of securing data on which to base its report, the Sectional Committee through its Sub-Committee No. 3 on Classification canvassed the various industries. This canvass was carried through by means of a questionnaire which was sent to a large number of companies typical of the industries handling large quantities of varied kinds of materials which are conveyed in pipes.

In the table which forms part of Appendix A is listed all the materials suggested in the replies to the questionnaire. In addition certain determinants of important physical characteristics are given together with the classification into the five main groups. (S) Safe Products, (D) Dangerous Materials, (P) Protective Materials, (V) Extra Valuable Materials, (F) Fire-Protection Equipment.

The Committee found that frequently certain materials which were at one time dangerous could fall in one or the other of the classifications. After discussing the matter with representatives of the industries the Committee has come to the conclusion that "once a dangerous material always a dangerous material"

should be the rule to be followed, and in the particular industry in which the dangerous material becomes the antidote or safe material, it should still be marked as dangerous. The few men who are in that industry should be directed by markings other than color to use it when necessary for their protection. In this way the hazard of having dangerous materials used on the wrong occasions for safe materials will be eliminated. An example of this is the use of ammonia, usually a dangerous material, as a safety material when attacking phosgene fumes. The contrary case, however, of a normally safe material becoming dangerous under certain conditions, should be met by having this material considered as dangerous only in those locations where it is dangerous, being classified by this committee as a safe material. An example is water over quicklime. In the case of drinking or service water systems with special outlets for fire protection, the Committee recommends that the fire outlets only be designated as fire protection, the remainder of the line to be classified as safe.

Classification of Materials Carried in Pipes

MATERIAL PIPED	PHYSICAL STATE GAS, LIQUID, OR SEMI-SOLID	TEMPERATURE	PRESSURE	or	VACUUM	CLASSI- FICA- TION
		OF MATERIAL IN DEG. FAHR. (MAX.)	IN LB. PER SQ. IN. (MIN.)		IN INCHES OF MERCURY OR WATER	
Acetic acid.....	Liquid	Normal	30 lb.		28 in. Hg.	D
Alcohol.....	Liquid	Cool	D
Amyl acetate.....	Liquid	Cool	D
Alum solution.....	Liquid	S
Acetylene gas.....	Gas	0 to 200	1/2 in. to 250 lb.		D
Benzol.....	Liquid	Cold	Up to 80 lb.		D
Brine.....	Liquid	Cold	About 60 lb.		S
Butyl alcohol.....	Liquid	Cool	D
Bleach liquor.....	Solution	D
Bisulphite liquors...	Liquid	D
Blau gas.....	Gas	00 to 200	1/2 in. to 250 lb.		D
Compressed air....	Gas	80	300 (in special cases 3000 lb.)		S

Classification of Materials Carried in Pipes (Continued)

MATERIAL PIPED	PHYSICAL STATE GAS, LIQUID, OR SEMI-SOLID	TEMPERATURE	PRESSURE	or	VACUUM IN INCHES OF MERCURY OR WATER	CLASSI- FICATION
		OF MATERIAL IN DEG. FAHR. (MAX.)	IN LB. PER SQ. IN. (MIN.)			
CO ₂	Gas and liquid	-30 to -100	0 to 250 lb. per sq. in. gage		D
Caustic soda solution	Solution	D
Chlorine.....	Gas, liquids, and solutions	D
Carbon bisulphide...	Gas and liquid	D
Chloroform....	Gas and liquid	D
Carbon tetrachloride	Liquid	S
Coal gas.....	Gas	0 to 200	1/2 in. to 250 lb.		D
Dyes.....	Solution	Usually cool	D
Flue gas or waste heat	Gas	0 to 200	1/2 in. to 250 lb.		D
Foamite.....	Liquid	Cold	Up to 100 lb.		F
Glycerine.....	Liquid	Hot and cold	Up to 60 lb.		S
HCl.....	Liquid	Up to 80	2 to 10 lb.		D
Hydrogen.....	Gas	D
H ₂ S Gas.....	Gas	0 to 150	1/2 in. to 100 lb.		D
Intermediates.....	Solution	Usually cool	D
Lactic acid.....	Liquid	Normal	60 lb.		20 to 22 in.	V
Mixed acid.....	Liquid	Normal	30 to 80 lb.		D
Miscl. solvent.....	Liquid	Cool	D
Mercury.....	Gas and liquid	29 in. to 100 lb.		D
Muriatic acid.....	Liquid	D
Natural gas.....	Gas	0 to 200	1/2 in. to 250 lb.		D
Nitric acid.....	Liquid	Normal	10 lb.		D
Nitro bodies.....	Liquid	Cool	Up to 40 lb.		D
NH ₄ NO ₃ (molten)....	Liquid	None		D
NH ₃	Liquid and gas	-30 to 100	0 to 250 lb. per sq. in. gage		D
N ₂ O and N ₂ O ₃ vapor.	Vapor	0 to 150	1/2 in. to 100 lb.		D
Oils (Petroleum)....	Liquid	Below 580	Below 1200 lb.		D
Paper sizing solution	Liquid	S
Pinch gas.....	Gas	0 to 200	1/2 in. to 250 lb.		D
Producer gas.....	Gas	0 to 200	1/2 in. to 250 lb.		D
Pyrox compounds...	Liquid	Up to 80	D
Paint.....	Liquid	Cold	30 lb.		D
H ₂ SO ₄	Liquid	Up to 180	30 to 80 lb.		D
Soda ash solution...	Liquid	Cold	60 lb.		S

KEY TO CLASSIFICATION

F—Fire Protection	—Red
D—Dangerous	—Yellow
S—Safe	—Green
P—Protective	—Blue
V—Extra Valuable	—Purple

Classification of Materials Carried in Pipes (Continued)

MATERIAL PIPED	PHYSICAL STATE GAS, LIQUID, OR SEMI-SOLID	TEMPERATURE	PRESSURE	OR	VACUUM IN INCHES OF MERCURY OR WATER	CLASSI- FICA- TION
		OF MATERIAL IN DEG. FAHR. (MAX.)	IN LB. PER SQ. IN. (MIN.)			
Sugar juices and syrops.....	Liquid	195 to 200	0 to 50 lb.	S
Steam.....	Vapor	Below 212	Below atmos.	S
Steam.....	Vapor	212 to 800	Above atmos.	D
SO ₂	Gas and liquid	-30 to 100	0 to 250 per sq. in. gage	D
Sulphur chloride....	Gas and liquid	D
Turpentine.....	Liquid	Cold	Up to 80 lb.	D
Toluene.....	Liquid	Cool	Up to 40 lb.	D
Tar.....	Liquid	D
Varnish.....	Cold and hot	30 lb.	D
Vapors of valuable materials not other- wise specified.....	Vapor	0 to 180	1/2 in. to 100 lb.	D
Water.....	Liquid	Cold	Any pressure	S
		Hot	Any pressure	D
Water gas.....	Gas	0 to 200	1/2 in. to 250 lb.	D

Example

In February, 1926, a Committee of the Technical Association of the Pulp and Paper Industry proposed a color code for the identification of piping in all paper and pulp mills. This proposal has been studied by the Sectional Committee and an adaptation in line with this Standard Scheme is reproduced to serve as an example of the way all the industries may make use of the Standard Scheme. Additional color stripes are indicated to illustrate the method, although the legend scheme for complete identification is considered preferable.

Identification of Piping Systems in Pulp and Paper Mills

		COLOR BAND	ADDITIONAL COLOR STRIPES
Steam	High pressure, Saturated	orange	white
	Superheated } 100 lb. and higher.....		white-gray
	Low pressure, Saturated	orange	white-black
	Superheated } 20 to 75 lb.....	
Low pressure, Saturated	orange	white-green	
Superheated } Atmosphere to 20 lb.....		
Vacuum lines, Atmosphere to 1 in. absolute.....	yellow	white-buff	
Water	Fire protection.....	red
	Fresh.....	green

KEY TO CLASSIFICATION

F—Fire Protection	—Red
D—Dangerous	—Yellow
S—Safe	—Green
P—Protective	—Blue
V—Extra Valuable	—Purple

Identification of Piping Systems in Pulp and Paper Mills (Continued)

Water, Cont.	COLOR BAND	ADDITIONAL COLOR STRIPES
Circulating.....	green-blue
Boiler feed.....	green	black
Blow-off.....	green	brown
Make-up.....	green	gray
Treated.....	green	yellow
Filtered.....	green
Waste or white water.....	green	white
Hot.....	green
Wash.....	green
Return condensate.....	green	black
Hydraulic piping: High pressure.....	yellow	green-red
Low pressure.....	green
High pressure, 50 to 125 lb.....	yellow	black-white
Low pressure, Atmosphere to 3 lb.....	green	black-white
 Clay, Alum, Size		
Alum.....	buff
Size.....	green
Clay.....	gray	white
Color.....	green (light)
 Groundwood Pulp		
Grinder pressure, Water supply.....	green
Oil supply.....	yellow	orange
Slush stock, No. 1 grade tailings.....	green	brown (gray flanges)
Low pressure.....	green	maroon (white flanges)
White water, High pressure.....	yellow	maroon (green flanges)
 Sulphite Pulp		
Gas, lead, or cast iron.....	yellow	purple
Acid, lead, and bronze.....	yellow	purple-red
Blow-off—obvious.....	black
Waste liquor, obvious unless reclaimed.....	green	purple-black
low pressure.....	green	maroon (white flange)
White water, high pressure.....	yellow	maroon (green flanges)
Sulphite brown stock.....	gray	brown
Sulphite, unbleached.....	gray
Sulphite, bleached.....	gray	white
Chlorine gas.....	yellow	yellow
Milk of lime.....	green	olive-white
Bleach.....	yellow	yellow-white
 Soda Pulp		
Caustic liquor, strong.....	yellow	brown (red flanges)
weak.....	yellow	tan (red flanges)
Carbonate liquor (green).....	green	brown-white

KEY TO CLASSIFICATION

F—Fire Protection	—Red
D—Dangerous	—Yellow
S—Safe	—Green
P—Protective	—Blue
V—Extra Valuable	—Purple

Identification of Piping Systems in Pulp and Paper Mills (Continued)

	COLOR BAND	ADDITIONAL COLOR STRIPES
Soda Pulp, Cont.		
Strong black liquor.....	yellow	brown-black
Weak black liquor.....	green	brown-gray
Brown stock.....	green	brown-buff
Unbleached stock.....	green	brown-gray
Bleached stock.....	green	brown-white
Sludge (lime mud).....	green	olive
Straw Pulp		
Same as Soda Mill		
Sulphate Pulp		
Milk of lime.....	green	olive
Old Paper		
Bleach liquor.....	yellow	yellow-white
Soda ash.....	green	brown-red
Defibered stock.....	green	black-gray
Unbleached stock.....	green	green-brown
Bleached stock.....	green	gray-green
Conversion		
Slush.....	green	gray-tan
Paper stock.....	green	gray-yellow
White water	}	green-white
Couch pit stock		
Broke stock		

KEY TO CLASSIFICATION

F—Fire Protection	—Red
D—Dangerous	—Yellow
S—Safe	—Green
P—Protective	—Blue
V—Extra Valuable	—Purple

Appendix B

Identification by Colors

For quite a long time pipe lines in various industrial plants have been painted in different colors for the purpose of ready identification. Of the various color schemes heretofore devised none has been based upon any definite fundamental principle, either scientific, psychologic, esthetic, or traditional. Because the selection of colors has been arbitrary and influenced by local conditions not common to plants in general, and because a comprehensive extension of such schemes soon involves a mass of detail which automatically renders them difficult if not impracticable, the inadvisability of recommending any of them for adoption as a universal Scheme is fairly obvious.

This condition was fully recognized by the Sub-Committee on Plan and Scope, a part of its report is therefore quoted below:

IDENTIFICATION

It is obvious that to attempt to outline a code in identification, would result in a system so comprehensive that even should the supply of colors and identification symbols hold out, adoption of it would automatically be rendered impossible in those industries which do not have a major group of colors allocated to its products. It is found, however, upon investigation that any materials transported in pipes in a plant fall in one of the following classifications:

(a) *Safe Products.* This represents a majority of the products that are handled through a plant. These products may be defined as having no hazard in their handling and no extraordinarily high value, so that a workman in approaching a piping system to make repairs will run no undue hazard in breaking into a pipe bearing a safe material, even though that material had not been emptied by previous arrangement.

(b) *Dangerous Materials.* These materials are those which in themselves are hazardous to life or property by virtue of being easily flammable or productive of poisonous gases or are in themselves poisonous. They include of course materials that are known ordinarily as fire producers and explosives.

(c) *Protective Materials.* Under this class are materials which are piped through plants for the express purpose of being available to prevent or minimize the hazard of the dangerous materials above mentioned. Thus, a plant may have certain special gases which are antidotes to poison fumes, which gases are piped for the express purpose of affording protection in emergencies.

(d) *Extra Valuable Materials.* These might be classified as a group of the safe materials above mentioned, but in as much as cases came to your committee's attention where those products would have a very high value, it appeared preferable to give them a separate major classification.

(e) *Fire Protection Equipment.* This might properly be called a division of the Protective Materials just mentioned above, though the hazard of fire and the use of automatic sprinkler systems and other fire-fighting equipment having become so universal, it would appear better to make it a special major classification.

These five classifications or subdivisions thereof, if necessary, in the opinion of the Committee should each be given a major color, and the various subdivisions that a plant may need can be obtained by the use of numbers, names, or the like, painted in white or black upon a background of the color selected.

The immediate problem of Sub-Committee No. 1 therefore, was to select a set of colors for these five major classes that would tend to relate, in some suggestive manner, one class with another.

In seeking some common starting point, the solar spectrum was decided upon as embodying a basic principle of color arrangement that is more or less universally understood. When the colors which compose the spectrum are grouped in their natural order in the form of a circle, an arrangement is established similar to that shown in Fig. 1. This color circle may be divided into any number of given parts that may be required, but for purposes of this code, five divisions or sectors, each covering a certain spectral region, have proved quite sufficient. Each of these sectors represents one of five main classes and is capable of subdivision, where necessary, into a larger number of hues having approximately similar dominant wave lengths, but distinguishable one from another very readily under favorable illumination (see Fig. 2). The logical arrangement of the colors shown in this circle enable complementary or opposite colors to be employed as designating a classification of a material directly opposite to one of the other materials appearing in one of the other main classes. For example, orange and blue are complementary or opposite colors and, in consequence, blue is selected as designating the protective materials that would be utilized to minimize hazard where dangerous materials, designated by the complementary orange color, were present. In the same manner, we find green indicative of safe products, as opposite to the complementary red which has

always been associated with fire and has, in consequence, been employed to designate fire protection equipment.

With regard to durability there seemed at first to be a general idea that the committee should select five or six indestructible pigments and have paints made from these only. A little reflection soon shows a position of this sort to be untenable, first because the resistance to attack is limited by the vehicle as well as by the pigment, second there are few substances either in the inorganic colored pigments or the organic vehicles that are equally immune to all the various forms of attack, and third the commercial availability of the materials from which practical and economical paints can be made is by no means a negligible factor.

The Committee therefore has concentrated its efforts on the presentation of a practical system having a sound claim to preference over any other heretofore suggested, and has avoided confusing the main point at issue with paint production problems which may be easy or difficult of solution according to the differing conditions in different plants. On the other hand the Committee has a detailed practical knowledge of what it is possible to produce in paints and has included in the system nothing beyond these possibilities. If a pipe contains extra hazardous material the only fundamental requirement is that it should be yellow; the shade of yellow, the kind of pigment, and type of paint or other coating, are matters of detail coming under the province of the engineer in charge. All the system requires is that the yellow shall be of such a kind that it will not be mistaken for the green, blue, purple, or red of the other main classes.

To show a number of variations of colors and illustrate the flexibility of the system, a set of color chips on paper has been prepared in a dozen or more different colors, which is submitted with this report as part of Appendix C. The vehicle in the sepaints is highly resistant China wood oil varnish more particularly useful for interior exposure where greater resistance to moisture than is afforded by ordinary linseed-oil paint is desirable. The paints will withstand temperatures up to 200 deg. fahr. for a reasonable time and, except the

reds, temperatures even higher than 200 deg. for a shorter time. For exterior exposure linseed oil will probably continue to be the most economical all around vehicle, but the system at all times permits any available vehicle best adapted to the prevalent conditions at any plant.

The system as suggested does not lose sight of an important fact in economical paint production, a fact which has heretofore taken a paramount position in the painting of iron and steel where the protection against corrosion has been of equal or greater importance than the color of the coating. Black, for instance, has been widely used, not only because it may be made at a low price, but also because it is practically the only paint that will withstand elevated temperatures without discoloration, has a relatively longer life under direct exposure to sunlight, and in the form of asphaltic varnishes is proof against all acids, alkalis, and sulphide sulphur compounds even in relatively strong concentrations. It is the ideal paint for pressure steam pipes, but we have taken the position that in most modern plants such pipes are insulated by various kinds of covering mostly white or nearly so, and in general not in need of any kind of paint. Such pipes may still be painted black as protection against corrosion, and the covering marked for identification by the colored bands, legends, and stripes.

The so-called metallic browns and other types of red oxide of iron have also been very largely used in low priced anti-corrosive paints. While the reflective value of the higher qualities of Venetian red is 19 per cent, or better, the darker shades run somewhat lower, and for this reason it is believed the dark browns may be excluded from the system with less sacrifice than attends any attempt to retain them.

Gold-bronze powders are of no special value and may be omitted without economic loss, but if included for any special reason would fall in the yellow or dangerous sector. Aluminum paints also are very useful in many cases and have been assigned to be used with the whites and grays to the identification of Safe Products (s).

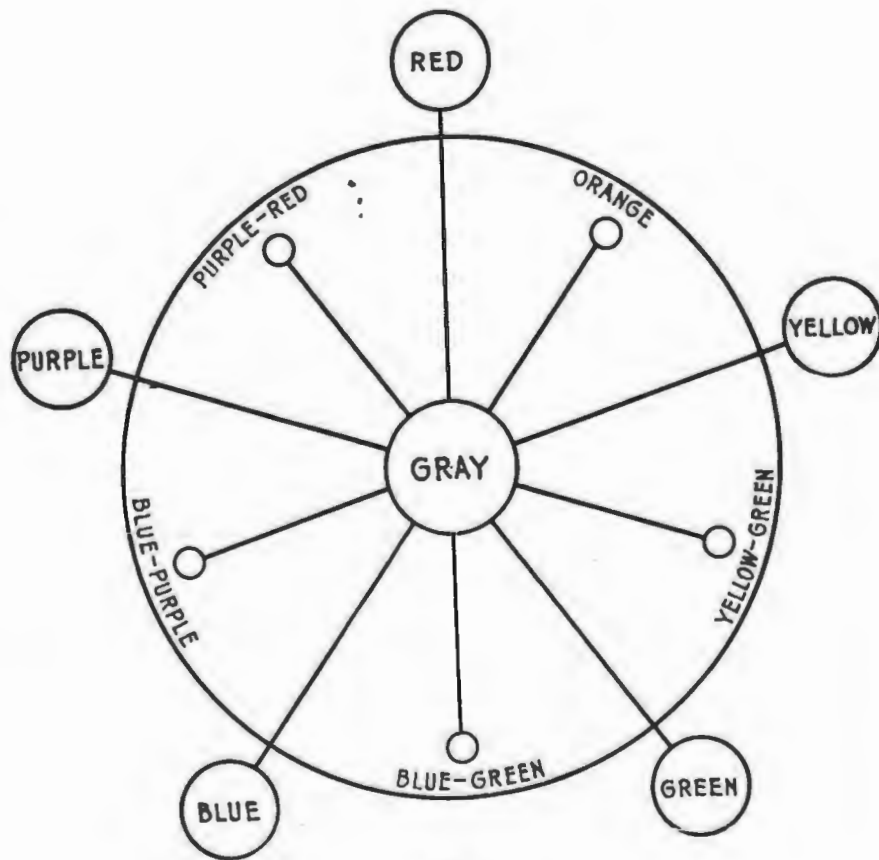

FIG. 1

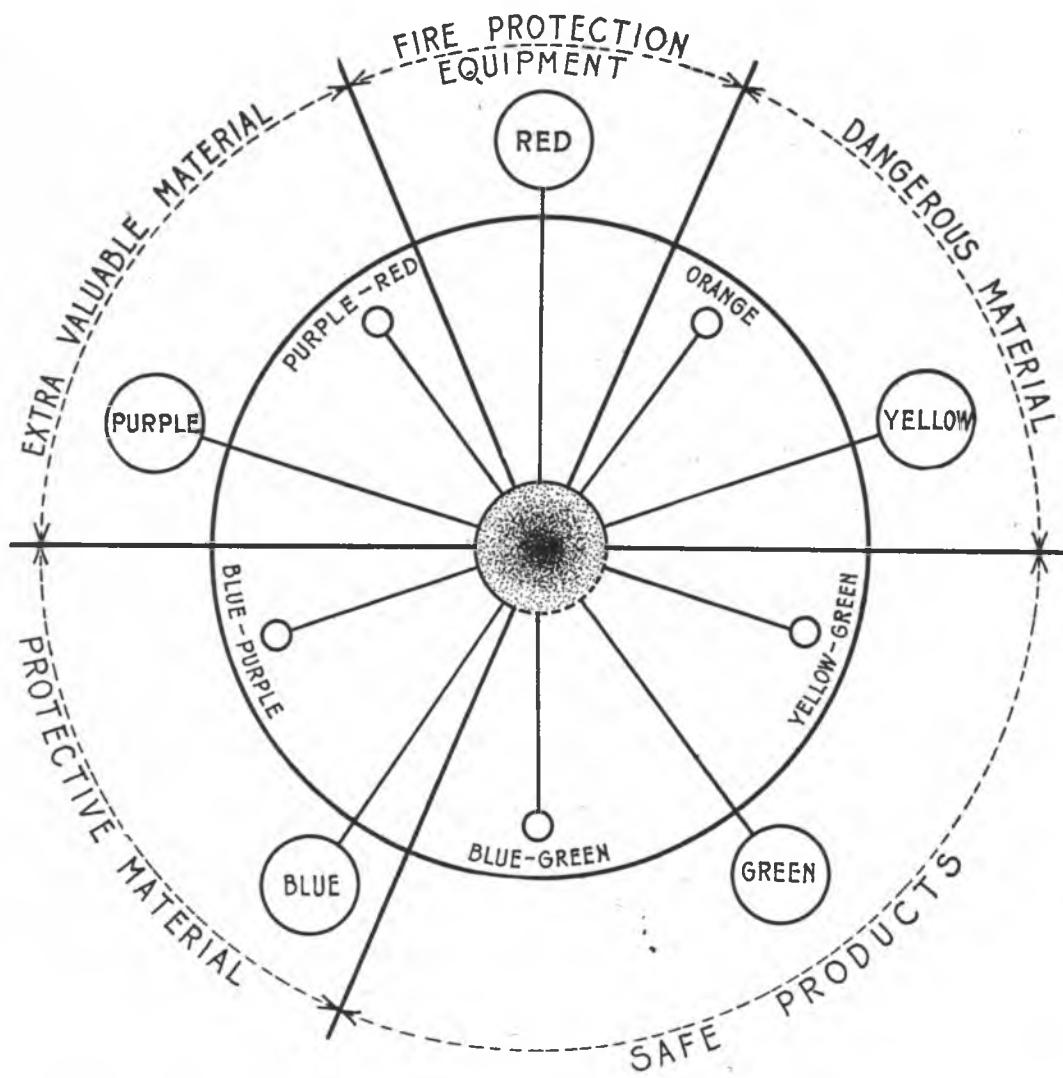

FIG. 2

Appendix C

Description of Colors for Special Application

To assist in the application of the standard Scheme for the Identification of Piping Systems the following description list of fourteen colored pigments is given. This list does not cover the entire range of available colors but merely serves to illustrate the means, at our disposal for meeting the more usual types of abnormal exposure conditions.

A plant atmosphere that will ordinarily support human life without material danger to general health, may at times be charged with gases or vapors that will react chemically on many paint pigments with a resultant change in color.

By far the most common of these abnormal forms of attack come from vapors that are acidic, alkaline, or sulphureted. The dry gases are far less active but when accompanied by aqueous vapor they penetrate the paint film, and, if reactive with the pigment, cause rupture of the film and change of color by the formation of new compounds having a different volume and color from the original pigment.

If the vehicle is sufficiently resistant it may delay such action for a longer or shorter time according to circumstances, but no paint vehicle now known is wholly impervious to osmotic penetration of this kind. In any plant, therefore, where such abnormal conditions persist, the first step is to use a vehicle having the highest practical water resistance and then select colors in such a way that the pigment will have the least reactivity with the prevailing gas. The colors here described are some of the possibilities in this direction.

Toluidin Red. Fairly fast to aqueous acids, alkalis, and sulphur. An organic pigment that will stand up as well as the vehicle. Adds materially to the life of varnish vehicles and works well with all of them.

Paranitranilin Red. Similar to the toluidin and considerably cheaper, but owing to a slight solubility in the vehicle it has a tendency to stain up through light shades or whites applied over it, e.g., white letters or aluminum stripes.

Red-Orange. A mixed pigment consisting of an organic red similar to toluidin mixed with zinc yellow. Fast to alkalis and sulphur but

not to acids. Shade of orange may be adjusted to suit. Mixed with cadmium yellow in place of the zinc yellow it becomes fast to acids as well.

Orange-Chrome Yellow. The regular color for ordinary use. Fast to alkalis but not to acids or sulphur.

Yellow. Yellow ochre toned up with bright yellow to a type commonly known as golden ochre. Ochre itself as compared with the more highly saturated hues is little more than a yellow-brown, but in the proposed system where browns as distinctive colors are eliminated the ochre falls unmistakably in the yellow sector. Owing to its general stability and low price it is the main reliance for fast yellow in situations where chrome yellows cannot be used. Like other iron compounds that contain hydroxyl groups or "chemically combined water," it is not wholly fast to sulphur. Strong ammonium sulphide darkens it somewhat but except in extreme cases it is fast to everything. When toned up to a brighter shade, the resistance depends on the kind and quantity of toner.

Cadmium Lithopone. A combination of cadmium sulphide and blanc fixe. Fast to everything, but applicable to extreme cases only because the available supply is limited and the cost relatively high.

Chrome-Yellow-Lemon. The ordinary pigment for general use. It is fast to acids but not to caustic alkali or sulphur.

Green. Chrome oxide toned up with a little yellow to raise its total reflection value. This oxide is a moderately low priced oxide not to be confused with Vert de Guignet, a much more brilliant and expensive quality. It is fast to everything and useful in extreme cases.

Ordinary Chrome-Green Light. Fast to weak acids but not to alkali or sulphur.

Prussian blue. A tint with a white base of Titanox. It is fast to acid, fairly resistant to sulphur and easily affected by alkali.

Ultramarine blue. A tint with a white base of zinc oxide. It is fast to alkalis and sulphur but not to acids.

Purple. Base white of Titanox tinted with alizarine purple. Fast to everything.

Shade can be adjusted by adding alizarine red in varying proportions.

Gray and Black. The achromatic colors white, black, and gray and aluminum are permitted for use in identifying safe products.

For ordinary outside exposure linseed oil is the most durable vehicle. Where higher resistance to water is required and, for interior use, China-wood-oil varnishes may be used to advantage.

Appendix D

Identification of Piping Systems by Legends

The first efforts of Sub-Committee No. 2 centered upon a combination of symbols or hieroglyphics along with a legend naming the nature of the containing fluid, the legend with its accompanying symbol appearing prominently at the points of supply to the piping system and at points of distribution therefrom; any further marking at intermediate points along the pipe line to consist of the symbol only.

The symbol idea was later entirely discarded since it was considered impracticable because of the great mass of detail involved, the difficulty an operating force would encounter in recalling to mind the different shapes and forms and the probable necessity for the publishing of a code book upon the part of each operating company.

The Committee finally arrived at the conclusion that this form of identification marking should consist principally of a lettered legend, abbreviated or otherwise, naming the material carried in the pipe line. Where a knowledge of the direction of fluid flow may be of service it is suggested that arrows be painted on the pipe.

Attention has been given to the question of visibility with reference to pipe markings and this committee recommends that where pipe lines are located some distance above the normal line of the operator's vision that the lettering be placed below the horizontal center line of the pipe as shown in the accompanying sketch, Fig. 4. This sketch shows a group of pipe located near a wall. It is desirable, where the view is unobstructed, that the lettering

employed be stenciled on the two lower quarters of the pipe covering rather than one side only. The lettering in the position shown will be less liable to be obscured by dust collection or mechanical damage.

In certain types of plants it may be desirable to label the pipes at junction points or points of distribution only, as suggested in Fig. 4. In certain existing power plants the markings are repeated at intervals all along the pipe line. In any case, the operating man should decide the location and number of signs required in each particular system of piping.

Regarding the type and size of letters and numbers, we recommend the use of stencils of standard sizes easily obtained from any stencil manufacturer, ranging in height from $\frac{1}{2}$ in. to $3\frac{1}{2}$ in. For pipes smaller than $\frac{3}{4}$ in. in diameter requiring identifying marks we suggest the use of a metal tag with the lettering etched and filled in with enamel.

Fig. 5 gives a tabulation and a diagram of suggested heights of letters for different outside diameters of pipes or pipe coverings.

With regard to visibility, the eye as a matter of habit, is most accustomed to the reading of black letters on lighter backgrounds. We therefore suggest that the black letters be either stenciled or painted on the band of main classification color when light and on a rectangular background when dark. The color of the background and the nature of the material used may be that deemed suitable for the purpose. Aluminum paint serves very well for this purpose.

Sizes of Stencil Letters

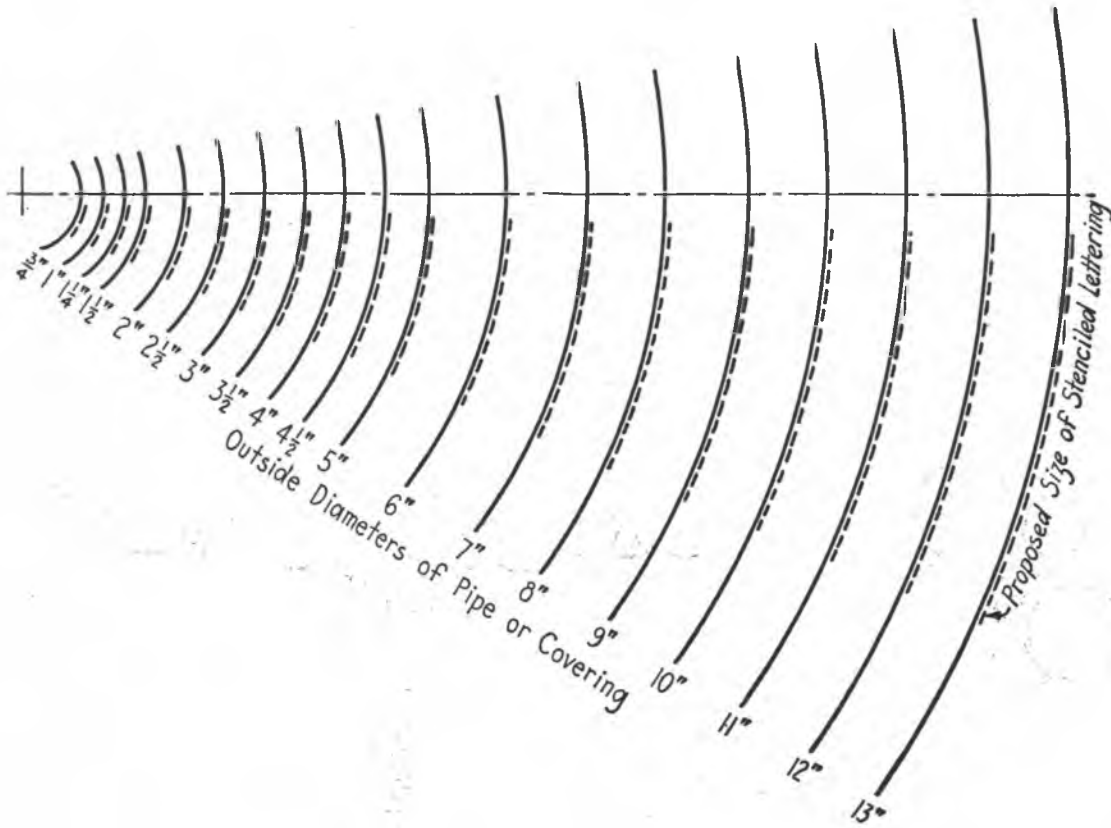

FIG. 5

Outside dia. of pipe or covering	Size of stencil letter
3/4"	1/3"
1"	1/2"
1 1/4"	1/2"
1 1/2"	3/4"
2"	3/4"
2 1/2"	7/8"
3"	7/8"
3 1/2"	1 1/4"
4"	1 1/4"
4 1/2"	1 1/2"

Outside dia. of pipe or covering	Size of stencil letter
5"	1 1/2"
6"	1 3/4"
7"	2"
8"	2 1/3"
9"	2 1/2"
10"	3"
11"	3"
12"	3 1/2"
13" and over	3 1/2"

Position of Stencil Legends

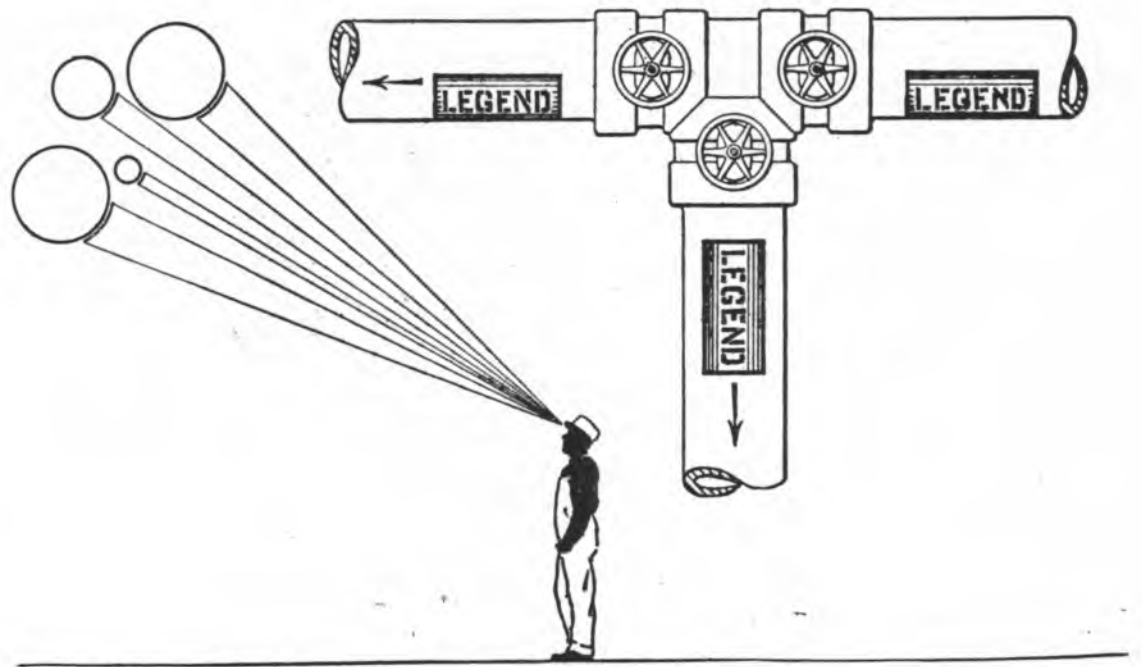

FIG. 4

CLINTON ENGINEER WORKS-TENNESSEE EASTMAN CORPORATION
SAFE OPERATING PRACTICES FOR CAB CONTROLLED CRANES

A COPY SHALL BE POSTED IN THE CAB

I. TRAINING OF CRANE OPERATOR

1. Only persons having passed a qualifying physical examination shall be assigned as crane operators. Periodic re-examinations shall follow.
2. Operators shall be familiar with the standard code of hand signals and shall be required to demonstrate their knowledge of such signals.
3. Each potential operator shall be thoroughly instructed and required to pass a qualifying examination in the operation of the crane.
4. The instructor shall require the operator to locate the main disconnect and auxiliary switches in the cab, and to identify the controllers.
5. The operator shall be required to make several lifts and moves, accompanied by the instructor, to demonstrate his knowledge of the signals and the correct operating methods.

II. CRANE OPERATOR RULES

1. Upon entering the cab of the crane, the operator shall make the following checks and tests.
 - a. With the main line switch open each controller shall be operated to full speed positions in both directions.
 - b. With no load on the hook the hoist shall be operated to test the limit switches.
 - c. With no load on the hook the bridge, carriage, and hoist brakes shall be tested.
 - d. Always stop the controllers in the "off" position instead of reversing instantly (the slight pause is necessary to give the braking mechanism time to operate).
2. In the event of power failure all controllers shall be returned to the neutral position immediately, and shall not be reactivated until the pilot light indicates power has been restored. Extended outage shall be reported.
3. Crane operators are not to be permitted to make any repairs or adjustments on the crane. They are not permitted to replace or renew fuses except in one of the following two conditions:
 - a. Operators may replace fuses in the cab where necessary to permit them to ground a suspended load.
 - b. Operators may renew fuses in the cab to permit them to bring the crane to the end of the bay for maintenance and servicing.

When an operator under one of the above classifications has renewed fuses, the crane shall be brought to the servicing platform and shall be checked by a qualified maintenance crew before being restored to service.

4. Tampering with circuit breakers, limit switches, and overcurrent devices shall not be permitted under any circumstances.

Safe Crane Operating Practices
Crane Operator

5. Hoist movement shall be terminated by operation of the controller; limit switches are for emergency only.
6. Under no circumstances shall the operator leave a suspended or hanging load; he must remain in the crane cab until he is relieved or the load is grounded.
7. During crane bridge or carriage travel, suspended loads or empty hooks shall be carried high to safely clear any obstruction and persons.
8. Warning signals by gong, horn, etc. shall be made before starting horizontal or lowering movements and shall be continued during such movements.
9. The operator shall observe the position of the chains, slings, or carrying devices prior to beginning a lift and shall warn floormen of unsafe conditions.
10. The operator is required to attend strictly to his designated duties, being alert to all calls for service; he shall remain in the cab and refrain from making demonstrations or displays of personal prowess or daring which tend to distract other employees. No horseplay of any type will be tolerated.

III. FLOOR RULES

1. The movement of any crane while handling material, or in doing repair work, shall be governed by the standard crane signals transmitted to the operator by a designated floorman identified by a white safety hat. However, an emergency stop signal must be obeyed regardless of who gives the signal.
2. Side pulls shall not be permitted.
3. Before moving a load the signal man shall see that cables, chains, slings, or other attachments are properly applied to the load and secured to the hoist; that loads are properly balanced and free from entanglements; and that no one is endangered by movement of the load.
4. Never pull a sling from under loads (set load on blocks so that cables pull free). (NOTE: Before moving a load, the crane operator shall call to the attention of the floorman any hazard he may observe.)
5. The foreman of the ground crew shall make daily inspection of chains, slings, and hoisting attachments.
6. Never attempt to straighten a load by swinging it against a wall, column, or any other object.
7. It is the foreman's responsibility to see that all employees shall be kept away from the load while in transit and while beginning to lift and that his floor crew be kept away except where necessary to guide or set the load.

8. Riding a load or crane hook is strictly forbidden.

9. Take special care not to overload auxiliary hoists (when there is any doubt about overload use the main hoist.)

IV. WORKING ON OR NEAR CRANE RUNWAYS

1. When necessary to work on a crane runway, or in any location where crane movement would endanger workmen, the foreman in charge of the work is responsible and shall notify the operators of all cranes using the same runway or the one adjacent thereto. Wherever practicable operation of the crane shall be suspended in the bay in which work is being done. In all other cases track stops shall be installed to isolate the section in which work is being done.

2. The foreman in charge of repair work to be done on or about the crane is responsible for locking open the crane disconnect switch. He shall place warning signs and flagmen on the operating floor to indicate that men are working above.

3. Whenever the crane is being repaired it is under the jurisdiction of the maintenance department and the instructions of the repair man must be followed explicitly.

4. Upon completion of the work, the foreman in charge shall make a careful inspection to assure that no tools, parts or debris are left lying about.

V. CRANE CONSTRUCTION

1. The trucks of the bridge and carriage of every overhead traveling crane shall be equipped with suitable guards in front of the wheels extending down below the level of the top of the rail and so designed as to clear the track of any objects.

2. When necessary a fender shall be placed to prevent the block or cable from swinging into the feeder trolley wires.

3. Cab cranes shall be equipped with brakes to control all movements.

4. Hoist cables shall be so reeved that at no time will there be less than two full turns on the drum when the block is lowered the maximum distance required to make a lift.

5. Where two cranes are operated in the same runway there shall be provided a device to prevent bumping.

VI. SWITCHES. WIRING. CONTROLLERS

1. The installation of all electrical equipment shall comply with the National Electrical Code.

2. There shall be a main switch in the leads from the main collector conductors capable of interrupting the circuit under heavy loads which shall be within easy reach of the operator.

3. A limit switch shall be provided for upper limit of travel of each crane hook.

4. At no time shall the sheave block be left at rest in contact with the limit switch,

VII. MAIN COLLECTOR SWITCH

1. The main collector conductors shall be controlled by a switch of ample capacity readily operable from the ground, and protected with an overcurrent device and locking out facility.

VIII. CRANE MOTORS

1. Each motor on a crane shall have individual overcurrent protection, except that if two motors operate a single hoist, carriage, truck or bridge, and both are controlled as a single unit by one controller, the pair of motors with their leads may be protected by a single overcurrent device.

IX. GROUNDING - BONDING

1. The crane tracks shall be grounded according to the National Electrical Code. The tracks shall be electrically bonded and joints machined flush.

X. CRANE MAINTENANCE

1. No person shall go on a crane for any reason before notifying the operator and being sure that the operator understands fully the nature of the mission.

2. Authorized maintenance men shall lubricate and make careful periodic inspections of all machinery, apparatus, and appliances, connected with the cranes, and shall report results of inspections on suitable check lists.

3. When any safeguard, machinery, or apparatus, is found defective or inoperative, the person discovering this condition shall report it immediately to the floorman or operator who shall report the defect immediately to the responsible foreman. The crane shall be removed from service until the damaged or defective equipment has been repaired.

XI. FIRE PROTECTION

1. Each crane shall be provided with fire extinguishers of types approved and recommended by the Fire Department. At least one such extinguisher shall be in the cab within convenient reach of the operator and another on the crane platform.

2. The Fire Department must be notified when extinguishers have been used.

XII. HOUSEKEEPING

1. There shall be no rubbish, equipment or supplies stored or left on or about the crane.

2. Clothing, lunch pails, and personal effects must not be brought into the cab unless storage facilities are provided.

3. The crane operator must keep the crane cage and landing platform clean at all times.

XIII. DUAL LIFTS

1. Dual lifts shall not be attempted except where completely unavoidable as in the instance where the load exceeds the capacity of the crane.
2. When dual lifts cannot be avoided, they should only be made on the direct order of the responsible supervisor and under his continuous personal direction. It is recommended that only the most competent operators be selected for this work and that they be trained as a team before attempting such an operation. These men shall be given the opportunity to make several practice lifts together under circumstances as closely approaching those of the intended dual lift as can be arranged.
3. When making dual lifts both cranes must be securely locked together with two approved couplings attached between the adjacent trucks.

STANDARD SIGNALS

for the
Operation
of
Cranes



MEMORANDUM

To: All Process and Refining Building Superintendents Date: June 29, 1945

Subject: Handling and Use of Oxygen and Acetylene

Copies To: A.D.Caley, John B. Rogers, Gentry Veal, G.C.Henderson, Leo Goldstein,
Lee Dagwell, E.D.Hughes, R.N.Stuart, J.W.Hughey

Attached is a revised set of recommended procedures for the safe handling and use of oxygen and acetylene, which supersedes the previous set dated November 25, 1944.

Two principal changes have been made:

- (1) Wherever it appears, the requirement that flash arrestors be serviced every week has been changed to a two week interval.
- (2) In accordance with the standard color code for piping systems, which has been adopted by many departments, and is in process of adoption by the remainder, paragraph 73 of the first page has been altered. Instead of specifying "red" for acetylene headers, the present TEC code calls for them to be painted yellow (ASA dangerous material class), with stenciled identification of the pipe contents to be painted on both oxygen and acetylene headers near all control valves.

Note: This proposed color code is available at the Safety Department office.

James M. Brown
James M. Brown
Chief Safety Engineer

/rb

To: All Process and Refining Building Superintendents Date: June 22, 1945

Subject: Handling & Use of Oxygen and Acetylene

Copies To: Messrs. A.D. Caley, John B. Rogers, Gentry Veal, G.C. Henderson, Leo Goldstein, Lee W. Bagwell, E.D. Hughes, and Chief J. W. Hughey

It has come to our attention that a number of precautionary measures are not being followed in the handling and use of oxygen and acetylene. These compressed gases are dangerous when handled improperly. The following conditions have been noticed:

(1) Some of the buildings are allowing full and empty cylinders to be left on the outside of the supply manifold sheds, exposed to all weather conditions. Usually the cylinders stand on end with no type of support to prevent falling, or are laid on their sides in the mud--sometimes scattered all over the road. As previously suggested, where overflow storage space is needed, additional sheds should be provided with segregated compartments for different gases. These sheds could be abutted against the outside wall of the building in the same manner as the present manifold sheds. Doors to manifolds and storage sheds should be kept closed and locked at all times.

Some buildings have provided wall chains in the vicinity of the freight entrances of the building for securing full and empty cylinders. This is good practice for empty cylinders, but spare stock of full cylinders should be kept in a separate, well protected, ventilated enclosure. The National Board of Fire Underwriters states that "Cylinders, stored inside a building, except those in actual use or attached ready for use, shall be limited to a total capacity of 2000 cu. ft. of gas. For storage in excess of 2000 cu. ft., a separate room or compartment as provided for by Section #5 (b) and (c) (requiring firewalls) shall be provided, or cylinders shall be kept outside or in a special building."

(2) Flash pots on the acetylene header in some of the buildings are not inspected, drained, or refilled. On several occasions, flash-backs have occurred in the acetylene service lines which resulted in the rupture of the bursting discs and temporary stoppage of work in the servicing departments. If not properly controlled, serious property damage together with personal injury can readily result from these flash-backs. The arrestors serve to isolate header explosions and prevent them from spreading to the acetylene supply manifold. Acetone vapors from supply cylinders will frequently condense and form an inflammable layer inside the flash pot. This is additional reason for routine servicing. It is recommended that all departments, in an effort to minimize the seriousness of possible header flashes, inspect and refill these arrestors every two weeks. Recommended procedure for so doing is attached.

(3) Oxygen and Acetylene headers and valves are not properly identified in many cases. Colorimetric identification in accordance with the proposed color code for TEC (Based upon ASA standards) places acetylene in the "dangerous material" classification and calls for headers containing this gas to be painted yellow. Oxygen headers should be painted green. Stencils indicating the pipe contents should also be painted on the headers at or near all control valves.

(4) Supply hoses to the torches are mixed up and attached to the wrong connections in a number of cases. Green hoses for oxygen are hooked to acetylene valves, and vice versa with the acetylene hoses. A new person accustomed to standard hose identification could easily make a mistake. Any oxygen equipment which has been misused on acetylene lines should be purged with inert gas (nitrogen) before being re-adapted.

(5) Flash-back check valves at the welding stations are evidently seldom inspected or cleaned. These frequently carbonize and stick during continued use. They should be examined at regular intervals. Several header explosions from flash-backs have already occurred on the area.

(6) Welding and cutting torches are seldom inspected or cleaned. This condition alone is conducive to flash-backs. Routine examination and cleaning should be maintained. Oil or grease should never be used on torch parts and fittings.

Attached is a list of "Safe Practices for Handling Compressed Gas Cylinders", and "Recommended Procedures for Servicing Acetylene Hydraulic Flash Arrestors" which will give additional information on these subjects. If further material is desired, please contact the Safety Department.

9

CLINTON ENGINEER WORKS
TENNESSEE EASTMAN CORPORATION

SAFE PRACTICES FOR HANDLING COMPRESSED GAS CONTAINERS

Compressed gas containers are safe for the purpose for which they are intended. Serious accidents connected with their handling, use, and storage can almost invariably be traced to abuse or mishandling.

GENERAL PRECAUTIONS

1. Do not abuse cylinders! Avoid rough treatment such as dropping them, striking two together, or letting them fall over. They may rupture or explode.
2. Do not use cylinders as rollers for moving heavy objects. They are breakable.

HANDLING

3. In moving cylinders to and from the location where they are used, do not roll or slide them along the floor or ground. Use a standard truck carriage with proper chain or clamp to prevent their falling.
4. In transporting cylinders, block them securely in the truck, be sure the valve protecting caps are in place; and lift, rather than slide, them off and on the truck.
5. Never use the valve protecting cap as a means of hoisting a cylinder; likewise, do not use a lifting magnet, nor a sling (rope or chain), but rather an approved cradle or cylinder platform provided for this purpose. Valve-protecting caps must always be in place.
6. Only cylinders approved for use in interstate commerce are to be used for the transportation of compressed gases.

USE

7. Always use a suitable cylinder truck, chain, or clamp to keep cylinders from being knocked over while in use.
8. Unless cylinders are secured on a special truck, be sure that regulators are removed and valve-protection caps, where provided for, are put in place before cylinders are moved to another location.
9. Never accept or use a cylinder with evident defects in the head assembly. Return it to the supplier for replacement. Likewise, do not attempt to repair it yourself -- send it back.
10. Never consider a cylinder as empty except when properly checked and marked empty. You may be mistaken, and in any case, there is probably enough residual pressure to be dangerous.
11. Regulators or automatic reducing valves shall be used only for the gas for which they are intended.
12. Do not force head connections that do not fit. They are easily stripped and broken.
13. Never handle the cylinder valve or supply connections with greasy hands or greasy gloves. Grease and oil may react with the gas and catch fire or explode. THIS IS ESPECIALLY IMPORTANT IN THE USE OF OXYGEN CYLINDERS.
14. If a cylinder is in service location but not being used for a specific job, always shut off the main valve and drain all gas from the regulator and supply hose. This is important.
15. Never use a new cylinder of gas without first testing the head connection for leaks with a soap solution. Test them at regular intervals during use, along with the supply lines. Flexible hose may be submerged in a bucket of water to test.
16. Do not twist, double up, or put a strain on flexible supply hose. It may break or pull loose at the ferrules.

Safe Practices for Handling Compressed Gas Containers
Use

17. Open cylinder valves slowly. Never use wrenches or tools except those provided or approved by the gas manufacturer. Never hammer the valve wheel in attempting to open or close the valve. WHEN OPENING VALVES, AIM GAUGE AND REDUCING VALVE AWAY FROM YOU.
18. Do not attempt to manipulate cylinder valves unless you are certain of the exact, proper procedure. Consult your supervisor if in doubt.
19. Always identify empty cylinders as such by a standard prescribed procedure.
20. Know the color scheme for all different types of cylinders. Never use one unless you are certain of the contents.

STORAGE

21. Store cylinders in dry, well ventilated locations, and in such a manner as to prevent falling or being struck by mechanical objects. Also keep them out of contact with corrosive chemicals and fumes.
22. Store oxygen cylinders separately from cylinders containing combustible gases.
23. Empty cylinders shall be segregated from full cylinders and promptly returned to the supplier with valve-protection caps in place. BE SURE ALL VALVES ARE CLOSED.
24. Avoid exposing any type of compressed gas cylinders to sunlight or other sources of heat. Keep all of them away from inflammable materials. They may explode.
25. All cylinders shall be marked according to Interstate Commerce Commission Requirements.
26. Cylinders must not be filled except by, or with, the consent of the owner, and then only in accordance with regulations of the Interstate Commerce Commission.

March 29, 1944

CLINTON ENGINEER WORKS
TENNESSEE EASTMAN CORPORATION
SAFETY DEPARTMENT

RECOMMENDED PROCEDURE FOR
SERVICING ACETYLENE HYDRAULIC FLASH ARRESTORS

The following procedure is recommended for draining and charging the hydraulic flash arrestors connected in the acetylene headers:

1. Shut off all valves on the service outlets.
2. Close inlet valve to arrestor.
3. Vent arrestor to air by opening relief valve.
4. Remove filler plug.
5. Drain by removing plug at bottom of arrestor.
6. Flush out with water by charging through the filler plug opening and fill to the overflow level after inserting drain plug at bottom of arrestor.
7. Replace filler plug.
8. Before placing back into service, purge air out of arrestor by cracking inlet valve, forcing air out through the vent line.
9. Close the safety relief valve.
10. Open inlet valve to arrestor.

Caution Notes:

1. When venting arrestor, check area near vent opening to make sure no open flames or possibilities of ignition will occur in the immediate vicinity.
2. After placing arrestor back in service, soap plug connections for leaks.
3. Never attempt to blow water out of arrestor with acetylene. If water fails to drain, unplug by working brass or bronze wire through drain opening.
4. Report all leaks or faulty valves to your supervisor. Don't attempt repairs.
5. For arrestors situated outdoors, an anti-freeze solution of half and half (1:1) glycerine and water should be used during the winter months.

Good practice requires that these arrestors be serviced at two week intervals.

CLINTON ENGINEER WORKS
Tennessee Eastman Corporation
Safety Department

129
125

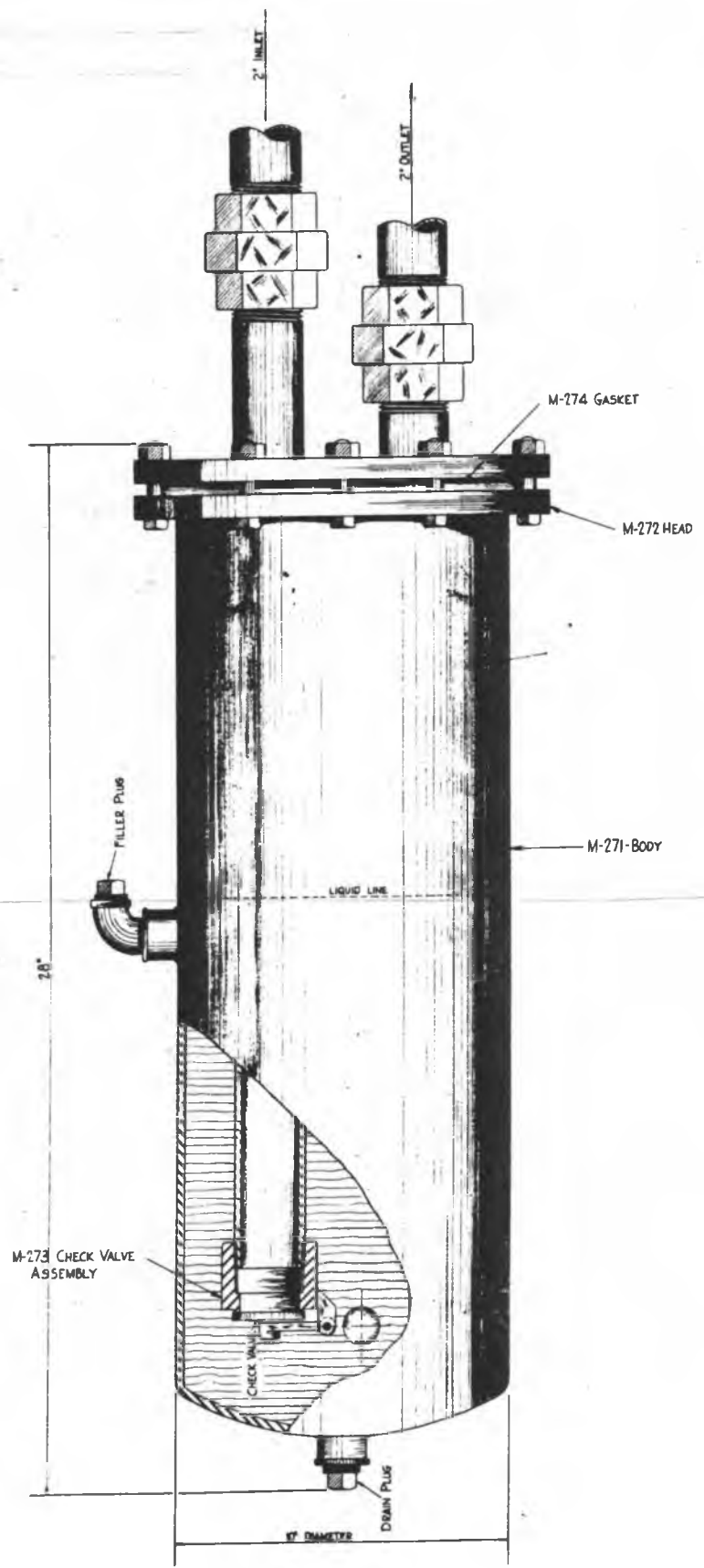

M-270 HYDRAULIC FLASHBACK ARRESTOR
WITH 2" CONNECTIONS

Electrical Division Procedure E7 101
Section N - 1
Issued: 4-2-45
Supersedes: 10-18-44

RE: ELECTRICAL HOLD OFFS AND LOCK OUTS

GENERAL

All maintenance, repair, and testing of electric circuits and equipment, other than those in or fed from Process and Refining High Voltage cubicles, must not be made until de-energized and protected as follows:

- (a) 154 KV, 13.8 KV, 2300 V feeders and associated equipment and 460 V Unit Substation ACB shall be Tagged.
- (b) All 460 V circuits, other than 460 V ABC, and lower voltage circuits shall be Locked.

Work on energized equipment shall be performed only by permission and under the constant supervision of an Electrical Division Foreman and when the work cannot be delayed until it is possible to de-energize the equipment.

TAGGING

TAGGING RULES

- I. Two types of Electrical Hold Off tags will be used on equipment under the jurisdiction of T.E.C.:
 - (a) Absolute "Hold Off" Tag (red) - When placed upon the control handle for any circuit breaker or switch, absolutely prohibits closing of that control. In addition the "Red" Hold Off Tag prohibits making alive the associated feeder, circuit, apparatus or equipment from any other source whatsoever. All work not requiring test voltage shall be performed under "Red" tag.
 - (b) Potential Test "Hold Off" Tag (Yellow) - When placed upon the control handle for any circuit breaker or switch absolutely prohibits closing of that control except by direct order of the holder. Test Voltage may be applied only by holder to the associated feeder, circuit, apparatus or equipment.
- II. Only a Foreman or higher of the Electrical Division shall request placing of Hold Off tags, except personnel on approved lists authorized in this procedure.
- III. On each approved Hold Off tag will be placed the name of the holder, never job titles, except the "Head Operator", Electrical Control for operating purposes. All tags will be filled out by the operator responsible for the tag placement.
- IV. "Red and "Yellow" tags shall not be used together on a single feeder or piece of equipment. Only one set of "Yellow" tags issued to one holder shall be placed at any one time on any feeder or equipment. This forbids "Yellow" tags issued to more than a single holder to be attached together on the same equipment. More than one Red Tag, each issued to a single holder be attached simultaneously to a single feeder or equipment, but all placed

- tags shall be properly removed before any re-energizing of the circuits.
- V. If the Hold Off request is for a manufacturer's representative to work on equipment already in service, it should be made to the Assistant Department Superintendent or the Head Operator, depending on who controls the equipment. The Assistant Department Superintendent or the Head Operator shall arrange the necessary hold-off as outlined under "Request". This manufacturer's representative will then work under the tag of a TEC employee.
 - VI. Hold Off requests for the Stone and Webster Corporation shall be made only by personnel on an approved list issued by Stone and Webster. All tagging for this personnel shall be handled the same as for TEC personnel.
 - VII. Before placing "Yellow" Hold Off tags the feeder and associated equipment shall be de-energized. Before placing "Red" Hold Off tags the associated breakers shall be de-energized and moved to a disconnect position and disconnects opened.
 - VIII. Hold Off tags shall be considered individual, and may be removed only at the direction of the individual originally requesting its placement. However, in the case of grave emergency, removal may be ordered by the Assistant Department Superintendent, Department Superintendent or higher, depending on the department having jurisdiction over the equipment involved.
 - IX. Removal restrictions for Hold Offs and Lock Outs are for the protection of the operating personnel and plant equipment. It is the responsibility of the personnel to request Hold Offs and place locks only when necessary, and to remove them as rapidly as is safely possible. Whenever feeders or apparatus are left in an operating condition, all Hold Offs and Locks must be removed.

154 KV SYSTEM

1. Request --

- (a) Normal hold off requests, not interfering with production, shall be in writing to the Superintendent, Plant Electrical Department. When the requested hold off interferes with production it will be referred to the Superintendent, Electrical Division, who will be responsible for obtaining permission from all operating divisions affected. When satisfactory arrangements have been made, the Superintendent, Plant Electrical Department will instruct the Foreman, Electric Control Operations to order necessary operations performed by the Roane-Anderson Electrical Operators in substations 1501-1 and 1501-2.
- (b) Emergency hold off request shall be made by persons so authorized by the Superintendent, Electrical Division on List A. After complete and positive identification in person or by telephone to the Head Operator, the line or equipment will be ordered cleared and the necessary Hold Off tags placed.

II. Procedure—

All 154 KV System Hold Off tags will bear an Order Number issued by the Head Operator as well as the name and badge number of the Requestor. The Head Operator will inform the Requestor immediately upon completing all operations, and give him the order number, time issued, and points covered by the hold off. The Head Operator will order the desired operations on the 154 KV system by telephone to the Electrical Operators in Substations 1501-1 and 1501-2. Upon completion of the necessary operations the Roane-Anderson Substation Operators will then place the requested Hold Off tags on all disconnects and clearance points within the substation areas, and notify the Head Operator. Similar Hold Off Tags will then be placed by the Head Operator on all disconnects and clearance points in the Y-12 area opened by this operation.

III. Removal —

154 KV Hold Off tags may be removed only by the direct order of the Requestor whose name, badge number, and order number are on the placed Hold Off tags. Request for removal will be made in person or by telephone to the Head Operator. After removal of placed tags in the TEC area, reclosing disconnects, and returning breakers to the operating position, the Head Operator will then order the Roane-Anderson Substation Operator to remove the remaining tags.

13.8 KV BUS FEED, BUS TIES, YARD AND CHEMICAL FEEDERS

I. Request —

Normal request, not affecting production, shall be made directly to the Head Operator, Electrical Control. When a requested hold off interferes with production it will be referred through to the Superintendent, Electrical Division, who will obtain permission from all operating divisions affected.

Emergency request shall be made directly to Head Operator, Electrical Control in person or telephone by personnel on authorized list A. After complete and positive identification, the Head Operator, Electrical Control will order the equipment de-energized and tags placed.

II. Procedure —

All Hold Off tags on this equipment will bear an order number issued by the Head Operator, Electrical Control. The Head Operator will order the necessary Control Room Operator to fill out and place the tags on the de-energized equipment. Tags for equipment outside the production buildings will be filled out by the Head Operator, Electrical Control, and placed as ordered by a member of the High Voltage Maintenance Department.

III. Removal —

Requests for removal of hold off tags on this equipment shall be made only by the holder directly to the Head Operator, Electrical Control. After complete and positive identification, the Head Operator, Electrical Control, shall order the tags removed and the equipment returned to the operating position.

13.8 KV UNIT SUBSTATION FEEDERS AND 2300 V EQUIPMENT

I. Request --

Normal Hold Off requests shall be made to the Assistant Department Superintendent. When the request will affect production, it shall be referred through to the Superintendent, Electrical Division, who will obtain permission from all operating divisions affected.

Emergency Hold Off requests shall be made directly to the Control Room Operator by personnel on list B.

II. Procedure --

The Control Room Operator after receiving approved normal or emergency requests shall fill out and place or have placed the necessary tags.

III. Removal --

Requests for removal or Hold Off tags on this equipment shall be made only by the holder in person to the Control Room Operator. Upon proper identification the tags will be removed and the equipment moved to the operating position. Reclosure shall be made when ordered by the Building Electrical Shift Foreman or higher.

"Z" MOTOR GENERATOR SETS

I. Request --

Normal requests for Hold Off shall be made in writing to the Building Electrical Superintendent. When the request will affect production, it shall be referred through to the Superintendent, Electrical Division, who will obtain permission from all operating divisions affected.

Emergency requests for Hold Offs shall be made directly, and in person, to the Control Room Operator by personnel on list B. If the request affects production it shall be referred for approval to the General Foreman on duty. Conflicting requests for placing tags by two requestors shall be referred to the General Foreman, who will arrange necessary adjustments.

II. Procedure --

Approved normal and emergency hold offs for Motor Generator sets shall be placed on the permissive switch of the OCB in the control room by the Control Room Operator.

Approved normal and emergency Hold Offs for Z DC bus, in all production buildings except 9201-1, shall be placed on the permissive switch of the OCB in the Control Room by the Control Room Operator after the synchronous machine or machines have stopped rotating. In 9201-1, tracks A-1 and A-2 Hold Offs for the Z DC bus shall be attached to the open disconnect switches on the positive Z side of the DC Bus Feed breakers and manually operated negative breakers. The synchronous motors shall be left running on tracks A-1 and A-2.

When a request is made to also de-energize the DC control circuits on the Motor Generator Control Board, a tag shall be placed on the opened DC control power supply switch to the Motor Generator affected.

III. Removal --

All requests for removal shall be made by the holder in person to the Control Room Operator, who will remove the placed tags.

460 VOLT AIR CIRCUIT BREAKER

I. Requests --

Normal and emergency requests shall be made by authorized personnel on a list issued by the Assistant Department Superintendent. Request shall be made in person or over the Building PAX.

II. Procedure --

When the Control Room Operator has positively identified the requestor, he will fill out the required tag. The assistant Control Room Operator shall de-energize, pull out and tag the requested ACB. The requestor will be notified when the breaker is tagged.

III. Removal --

All requests for removal will be made by the holder in person or over Building PAX to the Control Operator. The Assistant Control Room Operator shall remove the tag and reclose the breaker as ordered by the Control Room Operator.

LOCKOUTS

All circuits of 460 Volts and below, except 460 V Air Circuit breakers shall be locked out before maintenance, testing and repair. Equipment operating at higher voltages may also be locked out as well as tagged if requested by the tag holder and when facilities are available on the equipment involved.

Two type locks are used for Electrical Division personal protection:

- (a) TEC "Personal Lock" -- When placed upon the control handle of a switch absolutely prevents closing of that control. The key for this type lock is held only by the person placing the lock.
- (b) TEC "Department" Lock -- When placed upon the control handle of a switch absolutely prevents closing of that control. Keys for this type lock are held by the Building Electrical Shift Foreman.

I. Request --

When apparatus or circuits are to be taken out of service, the Operating Divisions affected must be properly notified. Upon completion of satisfactory arrangements, the Building Electrical Shift Foreman will require all personnel working on the equipment to place protective locks.

II. Procedure ---

Before any mechanical or electrical work is performed an individual lock for each worker shall be placed on the control switch or circuit breaker. This lock should be placed on the operating handle in such a way as to prevent energizing the circuit.

A personal lock shall be placed on the circuit by each workman, whether electrical or mechanical, involved in the work on the apparatus or circuits. Such locks are to be a part of each workman's tool kit. The key will be retained only by the workman who placed the lock.

III. Removal --

Under normal conditions lock removal shall be made only by the workman who placed that lock. Upon completions of the required work, the Foreman shall be notified, and after properly inspecting the apparatus or circuit he will order the locks removed.

If the apparatus or circuits are "locked out" for periods beyond a single shift a "Department" lock shall be placed instead of a "personal lock". The Building Electrical Shift Foreman on duty can remove the "Department" lock when the circuit or apparatus is returned to safe operating condition.

Approved:

/s/ J. L. Holton
Supt., Electrical Division

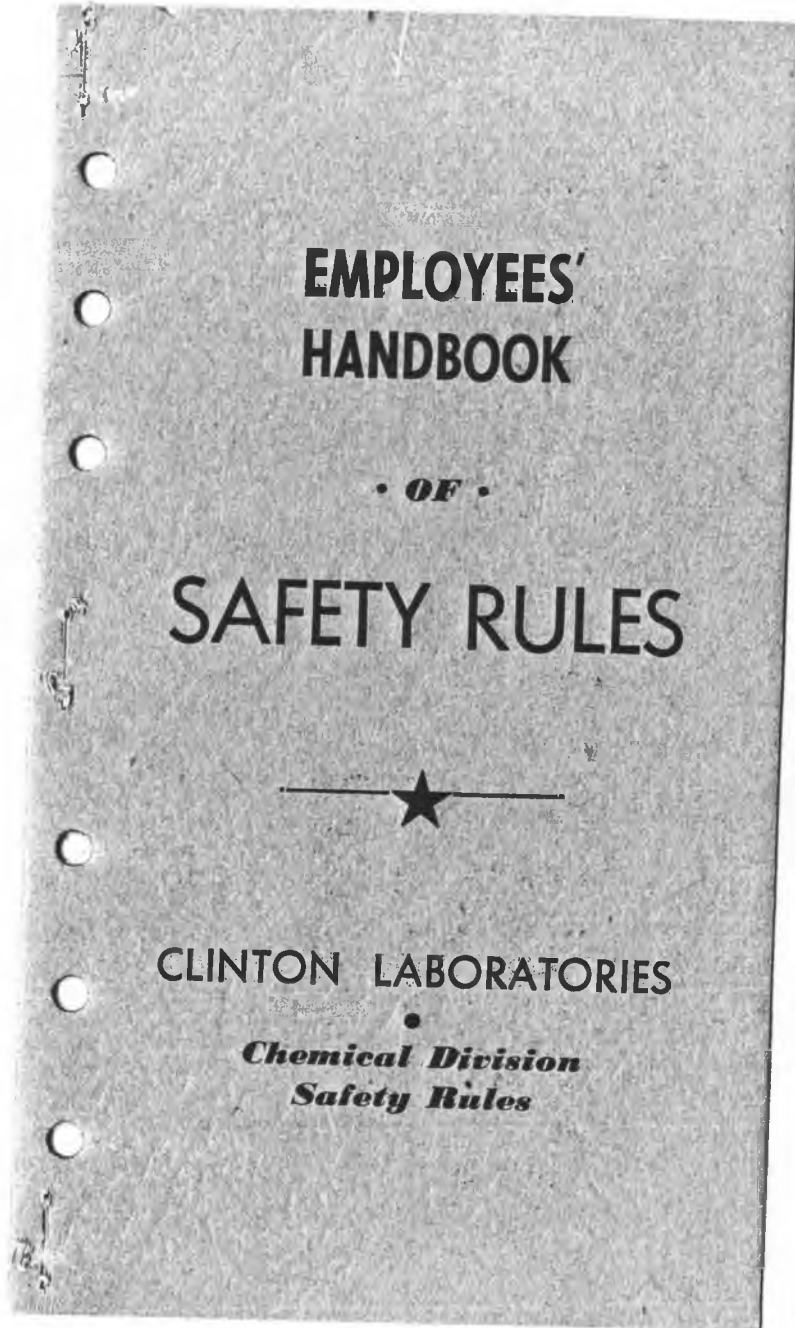

Similar Handbooks have been issued for the Power Division, Instrument Shop, Maintenance Department, Transportation and Traffic, and the General Plant.

Emergency Phone Calls

FIRE DEPT. CALLS

By Fire Alarm

Go to Nearest Fire Alarm Box, Pull the Guard down, and Press Down Firmly on Interior Hook.

Be Sure to Stay at the Box to Direct Firemen to the Scene of the Fire.

Learn the Location of All Alarm Boxes and Emergency Equipment in Your Area in Advance—This Will Speed Your Action If the Need Ever Arises.

By Telephone

Dial 6350

Be Explicit—Give Exact Location of Fire—Be Sure That You Are Understood, and **Stand By to Direct Firemen to Fire.**

AMBULANCE CALL 6171

MEDICAL SECTION

**Dial 6300 Days
6278 Night**

PATROL HEADQUARTERS

Dial 6360 or 6171

SAFETY DEPARTMENT

Dial 6344

**Keep This Booklet with You for
Ready Reference, and Consult
Your Supervision When in
Doubt As to How to Do
Your Job.**

Introduction

This Safety Booklet is dedicated to the prevention of personal injuries. You are requested to study it carefully, learn the safety rules in your department, and to conform to these safe working practices while on the plant.

It is your patriotic duty to keep yourself healthy and uninjured. Employee working hours lost now from injuries may cause loss of hundreds of lives on the battlefield.

If in doubt concerning the proper and safe way to do your job, **ALWAYS** consult your supervisor, who is ready to assist you with any problem.

Remember: **Your company does not require you to do any job that cannot be done safely.**

Any suggestions which you may have to promote safety, improve your working conditions or improve operating procedures will be most welcome. Suggestion Boxes for this purpose are placed at strategic locations throughout the plant for your convenience.



**Keep This Booklet with You for
Ready Reference, and Consult
Your Supervision When in Doubt
As to How to Do Your Job..**

CLINTON LABORATORIES
GENERAL PLANT SAFETY RULES

1. Report all injuries, no matter how slight, to your foreman and go to First Aid immediately.
2. Do not undertake any work or operation unless you have been instructed in the correct method of doing that work or operation.
3. Do not operate any valve, switch or equipment unless you have been given the responsibility for the operation involved.
4. Do not remove any "Danger" tag from any piece of equipment unless you placed it there. Do not operate any piece of equipment with a "Danger" tag on it.
5. Good housekeeping is necessary to safety and must be maintained. Slippery condition of floors and steps must be prevented. Walkways, passage ways, and operating areas must not be obstructed with tools, equipment, and materials.
6. No machine should be operated without all guards in place.
7. Goggles must be worn in all work where there is likely to be flying particles, corrosive or hot liquids, or other material capable of injuring the eyes. Special rules on each operation cover this matter in detail. Goggles must **always** be worn when metal is struck by metal.
8. Do not enter any boiler, heater, or other piece of equipment until all valves connecting to it have been closed, locked, and tagged or blanked off, and it has been declared safe by your foreman or supervisor.
9. Do not disconnect or open up any pipe line, vessel, turbine or pump casing, cylinder head or other equipment capable of holding pressure, until it is locked and tagged and tested by opening a free blowing bleeder to positively determine that all pressure is relieved from inside of it.
10. Do not attempt to lift or move heavy loads without adequate assistance.
11. Use leather gloves where your hands are likely to be cut, burned or bruised and always when operating steam valves.
12. No "horse play" or scuffling will be allowed on the plant.

13. Do not use any broken or defective tools or equipment. Use only the proper tool or equipment for any job you do. Chisels with mushroomed heads, split hammer handles, split ladders, are only a few of the defects that are not to be tolerated.
14. Do not put broken glass into any trash can. Put it into the special containers provided for this purpose.
15. Use trash cans for trash only, and rag cans for rags.
16. Do not permit strangers to enter your area without assuring yourself that they have business in there.
17. Tools should not be left lying on pipes, ledges, step ladders, etc.
18. Boxes, kegs, trestle benches, or any make-shift equipment should never be used to work or stand on; use standard equipment only.
19. Mark all outside roped-off areas at night with red lanterns.
20. Projecting nails should be removed or turned down at once.
21. Do not walk through any roped-off area.
22. Do not walk under over-hanging icicles.
23. Sleeves should be kept rolled down when working with chemicals and hot steam lines and valves.
24. When walkways are not available, walk on the side of the road facing traffic.
25. Each employee is held responsible for maintaining a high standard of housekeeping in the area of his work.

Safety Showers

1. Safety showers are located throughout the operating area and have a green light over each one. Determine the location of the nearest safety shower before you begin work.
2. Keep all approaches to safety showers clear.
3. Report to First Aid after using a safety shower.
4. Never work on any equipment which possibly might contain acid or caustic while the water to the safety showers is off. Never cut off water to safety showers until all operations in the area affected have ceased.

Reporting Fires

1. In case of fire turn in an alarm by dialing 6350. Talk calmly and be sure you are understood before you hang up. Be sure and give the building number and exact location.
2. Know the location of the nearest phone, gas mask, and fire extinguishers and know the proper use of each.
3. If you have no assigned responsibility in case of fire, report at once to your foreman or home shop. By all means stay away from the fire and out of the way unless asked to help by an authorized person.

Hazardous Materials

1. Obey all instructions. There are materials on this plant that are extremely hazardous unless properly handled.
2. All materials shall be placed in proper containers.
3. No work of any nature shall be performed in the operating areas without full instructions from your foreman. Be sure your presence is known to the operator and his permission has been given for the work to be done.

Goggles

1. Chipping and grinding goggles shall be worn at times when there is exposure to flying particles.
2. Acid goggles shall be worn whenever there is a possibility of acid splash, drip, spray, or fumes.
3. Face shields shall be worn when handling hot liquids such as molten lead. Goggles shall be worn under face shields at all times.
4. Persons watching or observing must wear the same eye protection as the man or men doing the work and should at all times conform to Safety procedures set up for the operation being performed.

Gloves

1. Acid resistant gloves shall be worn when there is a possibility of acid contacting the hands.
2. Leather gloves shall be worn where there is a possibility of bruising, cutting, chaffing, puncturing, or blistering the hands.
3. Contact your foreman for instructions in obtaining the proper gloves if your work requires them.

Ladders and Scaffolds

1. Any ladder should be inspected before being used.
2. Ladders must be held while being tied.
3. If a ladder is not tied, it must be held as long as anyone is on it.
4. Extension ladders are not to be taken apart and the parts used separately.
5. If a ladder is found to be in need of repair, do not use it; report it to your foreman.
6. Do not carry tools or equipment in the hands when ascending or descending a ladder. Use a hand line and tool bag if they will not fit in your pocket.
7. No more than one person is allowed on a ladder at one time.
8. Use only step ladders that are fully opened, or straight ladders with spikes resting on a plank at least 2"x6"x3" and tied at top or held at the bottom.
9. All portable, straight, and extension ladders shall be equipped with safety feet and with six feet of one-half inch rope spliced in the second rung from the top, or a six-foot section of safety chain.
10. In erecting a ladder, the feet must be kept one-fourth of the ladder length from the base of the object on which it is resting.
11. When using a step ladder, do not ascend higher than the second step from the top. When using a straight or extension ladder, do not ascend higher than the third rung from the top.
12. When not in use, all ladders must be kept on racks provided for them. Under no circumstances is a ladder to be left standing overnight without adequate protection to prevent it from falling or being bumped into by passers-by.
13. Do not use a ladder that is too tall or too short. Get the proper length ladder.
14. Never leave equipment on top of step ladder or hanging from straight or extension ladders.
15. Never stand on handrails, machine guards, piled boxes, or make-shift devices. **Get a ladder.**
16. Never take your hands off the rails while climbing a ladder. If you must work while on a ladder, equip yourself with a safety belt and still try to keep one hand on the rails.

17. Never lean far to the side while working on a ladder. Get down and move the ladder to the right position.

Danger Tags and Locks

1. Under no conditions is it permissible to work on any type of moving equipment until its operation has been prevented.
2. A "Danger" tag and padlock shall be used for the purpose of preventing operation of a valve, switch, or piece of equipment.
3. The attached "Danger" tag must be signed to be effective, and only one signature per tag is permitted.
4. Under no condition shall the switch, valve, or equipment be operated until the lock and tag have been removed by the person attaching the tag.
5. Never depend on an energizing or butterfly switch for protection. Tag and lock out the disconnect switch of the equipment involved.
6. When the situation concerns more than one department or craft, each shall apply its own tag or lock.
7. Each tag or lock can only be removed by the man applying the tag or supervision of senior supervisors, or higher level, in the event the condition carries through a shift change.
8. The reason for application of the tag or lock must always be stated on a "Danger" tag.

Work on Acid Lines, Valves, or Pumps

1. Locate nearest safety shower and be sure the way to it is kept clear of obstructions. Have a hose and running water ready to play on acid spills.
2. Area must be roped off and danger signs posted. Men on lower levels must be warned.
3. Trace down all connecting lines and make sure that any "flow back" or "back pressure" is impossible. Regardless of other precautions taken, regard all acid lines as full when breaking flanges.

Overhead Work

1. When overhead work must be done, the area below the work, subject to falling objects, splashes, drips, etc., must be roped off. If necessary, signs shall be

placed, and a man posted on guard. Be sure to warn any operating personnel of the affected area.

2. Avoid working under a fellow employee whenever possible. If such becomes necessary, a hard hat must be worn.

Open Holes and Pits

1. Open holes or pits must be guarded by a wooden rail or roped off. If rope is used, loosely wrap rags at intervals to increase visibility of the rope.
2. Excavations left open overnight shall be indicated by adequate lights.

Electrical Equipment

1. Any changes in electrical equipment are to be made by electricians **only**.
2. Stand to the right of switches and operate handle with your left hand.
3. All extension cords, portable electric drills, drop lights, etc., must be numbered and sent to the Electrical Department for regular checking.

Cleaning of Equipment

1. Equipment to be worked on in the operating areas will be turned over to the Maintenance Department by the Operating Department, clean, safe, and ready for mechanics. Extensive co-operation in this respect is required.

Operating Machinery and Equipment

1. Only authorized persons are permitted to operate machinery and equipment.
2. Before operating any machinery or equipment, consult your foreman, who will furnish instructions and proper supervision.
3. Be sure all guards are properly in place before operating any equipment.

Washing Down Equipment

1. Use only as much water as is necessary.
2. Avoid turning water on electrical switches or equipment.
3. If it is necessary to wash electrical fixtures, call an electrician. Turn off lights and allow globes to cool for two or three minutes to avoid cracking.

CHEMICAL DIVISION GENERAL LABORATORY SAFETY RULES

Part I

The general rules listed below cover the usual laboratory hazards to be encountered here. Anyone uncovering additional hazards or suggesting changes in these rules should report them to H. S. Brown. The rules are to apply to all general laboratories excepting special ones in which there are special hazards inherent in their use. Special rules will be written to cover these rooms.

Any of the following rules may be modified or abrogated if in the judgment of the shift or group leader the rule in question seriously interferes with the successful prosecution of the work, **and provided** such shift or group leader submits a written report to the chairman of the divisional safety committee (Johnson) explaining the change or abrogation of the rule.

Report all injuries, immediately, to supervision and the health division. In case of accidents wherein a weight-bearing part of the body is involved or where there is any doubt as to the seriousness of the injury, a doctor should be called or the patient taken to First Aid in the ambulance.

I. Housekeeping

A. **The use of hazardous materials** in research and development makes good housekeeping of the utmost importance. Laboratories must be kept in a neat, orderly condition. Floors, shelves, and tables must be kept free from dirt and from all apparatus and chemicals not actually necessary. The janitor is available for assistance in housekeeping.

B. **Keep everything in its place.** Items should be picked up at once when dropped on the floor.

C. **Equipment stored on shelves** should be so placed that it cannot be jarred off easily.

D. **All necessary piles of equipment or materials** must be made structurally sound. Place all unused equipment in storage, if available.

E. **Food and clothing** must not be kept in the working areas, provided adequate locker space is available. Laboratory glassware shall not be used for food containers. Lunches are not to be eaten in the laboratory.

F. **Waste receptacles** should be supplied for materials of all kinds, and as many different receptacles should be provided as may be necessary to avoid mixing dangerous materials.

G. **Dispose of all inflammable** packing materials immediately.

II. Safeguards

Before undertaking any unfamiliar operation, be sure you know the method of operation, the hazards involved, etc. Know the location of all safety and fire protection equipment in your vicinity. Test safety showers weekly.

A. **Smoking** is permitted in all areas except those posted "No Smoking." The use of strike-anywhere matches is discouraged.

B. **Eye protection** is required in laboratories and shops. The degree of protection required varies with the extent of the hazard. Cover-all goggles must be used during mechanical operations such as chipping and grinding where particles may fly. At all times hardened lens spectacles must be used in shops, laboratories and semi-works. Correction spectacles, unhardened, are considered as satisfactory protection only until hardened prescription glasses are available. Goggles and plain hardened lens spectacles are stocked in the storeroom. Spectacles with correction lenses are handled through the Medical Division on receipt of employee's prescription. Adjustments are made by the plant Medical Division.

C. **Foot protection** is required wherever temporary shielding is used or shielding blocks are handled.

D. **Hands must be protected** from contamination as well as from cuts, abrasions and burns. Hands should be thoroughly scrubbed before eating, smoking or leaving the plant. Rubber or rubber impregnated gloves must be worn whenever large quantities of acid, alkali or other corrosive liquids are handled. Cotton or leather gloves must be worn when handling concrete blocks, lead bricks or other rough or heavy objects.

E. **Coveralls or laboratory coats** must be worn by all personnel working in laboratories or semi-works, this rule to become mandatory when such coveralls are available to all. Coveralls are recommended.

F. **All-Service gas masks** for emergencies are available. Learn the locations of these.

G. **Adequate ventilation** should be maintained in all working areas.

H. **After working hours** no laboratory or semi-works operation should be continued unless adequate safeguards for the operator are provided. Another man must always be within calling distance unless otherwise designated by supervision.

I. **All moving parts** of heavy machinery must be enclosed or adequately guarded. Loose clothing should not be worn near operating machinery.

J. **"Horse play" and "stunt"** experiments are forbidden.

K. **Do not open the top of a centrifuge** until rotation has stopped.

L. **Molten materials, oil baths, etc.** used at high temperatures should be handled in such a way that the material will not spill or splash on the user should the container break.

M. **If lusteroid tubes are to be remolded** by dipping in hot glycerine, the following set-up must be used: glycerine in a metal container heated by an electric hot plate, the container and hot plate securely clamped to avoid tipping or accidental displacement.

N. **Gas burners** must be turned off at the petcock rather than at the base of the burner.

O. **Stopcocks** on compressed air, gas, vacuum and water lines should be closed before leaving unattended. Changes in pressure may cause rubber tubing to become loosened with resultant damage.

P. **Electric ovens** used for drying lusteroids or vaporizing organic materials must never be latched shut.

Q. **Repairs to electrical equipment** (electronics circuits excepted) should be made by an electrician. Repairs to electronics circuits are to be made only by authorized persons of the electronics or instruments groups. Supervision can make alterations to this rule where necessary.

R. **Electrical grounding** is required on all equipment connected to any plant electrical services. Incorrect replacement of wires on extension cord plugs may result in equipment being more dangerous than if ungrounded. Three-prong grounding plugs are required on all portable equipment.

S. **Most electric refrigerator units** have motor and

lamp switches located inside the refrigerator. Care should be exercised not to put any materials in the box which could form explosive air-vapor mixtures at the operating temperature of the box.

T. **Pipetting** by mouth suction will not be permitted with hazardous solutions. Use bulb or vacuum line in all such cases.

U. **High pressure operations** must be carried out behind adequate safety shields. Equipment for vacuum and for pressure work should be carefully designed and constructed.

V. **Desiccators** under vacuum should be protected against breakage by suitable shields.

W. **Flat-bottomed flasks** should not be used under vacuum unless made of heavy glass and used cold.

X. **Use Pyrex** instead of thin glass Dewar flasks when possible. Dewar flasks **must** be taped or inserted in metal containers to protect the user from explosion and flying glass.

Y. **Glass under pressure** is very uncertain. Failure occurs over a wide range of pressures. Annealing is very important. Full protection by gauntlet and towel when handling and by shield when operating is necessary.

Z. **Castalloy clamps** are made from zinc and are accordingly low melting and of low tensile strength. They should not be used to support vessels being heated directly by gas or electric heater. Convection currents from heaters have melted tips two feet above the burner.

AA. **Compressed gases and liquids in large cylinders** should be piped into laboratories from outside storage whenever their use is anticipated for an extended period. Cylinders moved into the laboratory temporarily should be securely strapped or chained. Where the quantity of gas required is small, the small laboratory cylinders should be used. When gas is not being used, the cylinder valve should be closed. When opening valves on cylinders of gases, the operator should stand as far away as possible from the valve and reducing mechanism and to one side of the discharge pipe. Gas cylinders should not be set up directly beside a flask which is being heated. They should not be kept in a hood when reactions with flammable material are being carried out. Cylinders containing more than a few pounds of pressure should have a regulating needle valve. Cylinders

may not be heated by means other than hot water or infra-red radiation lamps, and no portion of any cylinder may ever be heated above 100° C.

AB. **Bottles of hydrogen peroxide**, once opened, should be only loosely stoppered thereafter.

AC. **Spilled mercury** must be cleaned up at once.

AD. **Dry ice** or liquid air should never be stored in a container which can be accidentally stoppered.

AE. **Fuming material** should be handled under a hood or with a gas mask.

AF. **Bottles or other containers**, when filled, should always be labeled. To use unlabeled materials is dangerous and is forbidden.

AG. **Inflammable or highly volatile solvents** may not be stored in Building 706-A in greater than one-gallon quantities. Use the outside storage shed for larger quantities.

AH. **Filled five-gallon bottles** containing noninflammable liquids must be carried in wooden crates or in pails. Bottles of this size sometimes slip from the bare hands and are broken, causing cuts in addition to whatever hazard the material in the bottles may involve.

III. Laboratory Chemical Disposal

A. **Acids and strong alkalis** in small quantities should be drained into the sink while flushing with water. Such materials should never be put into the refuse containers.

B. **Flammable liquids** in large quantities not miscible with water must be collected in a closed metal can and burned at the burning yard or poured into an outside solvent waste can. Those miscible with water can be poured down the drain if dissolved in at least twenty parts of water; otherwise they should be treated in the same manner as the non-miscible liquids.

C. **Cyanides and other materials** capable of evolving poisonous gases must not be emptied into drains or sewers.

D. **Toxic and sensitive chemicals** from the laboratories must be disposed of under designated supervision (group leader).

IV. Chemical Hazards: Toxicity

A chemical compound should be regarded as toxic if it can cause any appreciable disturbance of normal physiology. The fact that it does not produce spectacular dam-

age is no indication that it is harmless. Absorption of toxic materials can occur by inhalation, by mouth, or by skin contact.

By inhalation, concentrations as low as one part per million in the atmosphere of a laboratory or work shop have caused significant harm in the case of certain compounds. Whenever compounds are inhaled they are also swallowed, since material entering the nose and mouth can be partially dissolved in saliva and so enter the stomach. Inhalation can usually be controlled by proper ventilation.

Skin contact is a very common method of absorption and can be avoided only by scrupulous cleanliness both of the person and of the clothing.

It must be remembered that the solubility of compounds in the test tube is not an indication of the solubility of these compounds in the body. Therefore the fact that a compound is relatively insoluble must never be taken to indicate that it cannot damage the living tissue (for example, silica is relatively insoluble but can cause serious lung damage).

The following groups of compounds should be regarded as hazardous and should be handled with every possible care:

Gases—Carbon monoxide
Hydrogen sulfide
Hydrocyanic acid
Cyanogen
Sulfur dioxide
Sulfur trioxide
Phosgene
Gaseous hydrocarbons
Nitric oxide (NO)
Nitrogen dioxide (NO₂)
Nitrous oxide (N₂O)

Hydrogen sulfide and hydrogen cyanide are dangerous materials and should be used under a hood. Solutions of cyanides should be disposed of by a chemist and not left for those who do not know the danger. Artificial resuscitation and oxygen inhalation are first-aid measures for hydrogen sulfide, nitrous oxide and carbon monoxide poisoning. In case of inhalation of NO₂ fumes, absolute immobilization must be enforced and the hospital notified at once.

Solvents—All solvents, even though they might be relatively inactive from the chemical standpoint, should be regarded with great suspicion until proved non-toxic.

Those definitely known to be toxic include:

- Aniline
- Methyl alcohol
- Benzene
- Toluene
- Xylene
- Halogenated hydrocarbons, both aliphatic and aromatic
- Ethylene glycol
- Diethylene glycol
- Esters of ethylene glycol (cellosolve and methyl cellosolve)

Other organic chemicals—The following group of chemical compounds should be regarded as potentially toxic:

- Formic acid
- Formaldehyde
- Aliphatic and aromatic amino compounds (including hydrazine and hydroxylamine)
- Aliphatic and aromatic nitro and dinitro compounds, especially dinitro and dinitrochlor compounds
- Aliphatic and aromatic sulfur compounds containing -SH or -S-S groupings
- Quinones
- Alkyl compounds of lead, mercury, tin, silicon (e.g., tetraethyl lead)
- Alkyl sulfates (e.g., dimethyl sulfate)
- Phosphates and phosphites of phenols (e.g., diortho cresyl phosphate)
- Acid anhydrides and chlorides
- Dowtherm and allied heat-transfer aids (While not active poisons, these have a cumulative effect which results in bodily changes after long exposure. They are readily absorbed by the skin and by clothing, particularly leather and wool. In case of exposure the exposed parts should be washed and the clothing should be aired.)

Inorganic substances—Toxic inorganic substances include the following:

Lead, mercury, silver, copper, osmium and their compounds

Silica

Fluorides

Chromium salts and chromates

Zinc in the form of soluble salts

Arsenic compounds

Antimony compounds

Tuballoy compounds

V. Chemical Hazards: Fire and Explosion

Violent exothermic reaction and rapid decomposition of unstable compounds is an ever-present hazard in most laboratories. Chemists should keep aware of this hazard and use explosion shields when in doubt. A number of common chemicals react in this manner when subjected to the wrong conditions. There are also lesser known compounds that have been found by experience to be unstable. Dangerous materials should never be turned over to helpers without warning.

Whenever ethyl ether must be used in the laboratory, it should be used in the hood or in an enclosed system and then only when a CO₂ extinguisher is in the immediate vicinity.

Hazardous common chemicals, such as sodium, potassium, phosphorus, chlorates and sodium peroxide, should be kept in the laboratory only under direct supervision of the group leader responsible for the operation involved.

Any equipment in which non-inert gases have been used or measured must be thoroughly flushed with an inert gas (N₂, CO₂, He) immediately after use.

A. Perchlorates

The use of perchlorates should be avoided where possible. Magnesium perchlorate is the most common reagent. It and other perchlorates should be used with the following restrictions:

1. Only persons thoroughly familiar with the hazards involved should be asked to handle vessels containing these materials. Handling of spent or fresh perchlorate drying agents should not be left to janitors, clean-up men, or laborers.

2. Perchlorates should never be used as drying agents where there is possibility of contact with a strong enough dehydrating acid to permit formation of perchloric acid over 70% in strength.

3. Perchlorates should not be used where other safer drying agents will give satisfactory results.

With dry alkyl halides, perchlorates react to form free halogen acids and explosive quantities of perchloric acid. Silver perchlorate crystals are highly unstable.

An ASTM pamphlet supplies the following information concerning perchloric acid:

While perchloric acid of 70% strength may be boiled with impunity at approximately 200° C., it cannot be too strongly emphasized that contact of the boiling undiluted acid or hot vapor of perchloric acid with organic matter, or even easily oxidized inorganic matter such as compounds of trivalent antimony, will lead to serious explosions. If oxidizable substances are present, nitric acid must be always added as a precautionary measure before the addition of perchloric acid and evaporation of fumes of the acid. Do not use rubber thumb stalls around fuming perchloric acid. Handle with beaker tongs. Perchloric acid evaporations should be done in a hood with good draft. Hoods with wood frames in which a great deal of HClO_4 is fumed should be washed occasionally with water. Perchloric acid fumes attack wood, making it very inflammable. Also, the fumes condense in the hoods, and may form explosives with ammonia and nitric acid fumes. Frequent (weekly) washing out of the hood and ventilator ducts with water is necessary to avoid danger of spontaneous combustion or explosions where this acid is used constantly.

B. **Sulfuric acid and potassium permanganate** solutions used in purification in absorption trains should have an empty trap between them.

C. **Phosphorus trichloride** containing moisture may, under certain circumstances, form some phosgene when heated, and explode violently.

D. **Aluminum chloride** should be considered as a potentially dangerous material. If moisture is present, sufficient decomposition to build up considerable pressure may result. If a bottle is to be opened after long standing, enclose it completely in a heavy towel.

E. **Diethyl and diisopropyl ether** have been known to explode violently because of the formation of peroxide during heating or refluxing. Ferrous salts or sodium sulfite will decompose these peroxides; titanium salts will give color reactions (Chem. Zentr., 1928, p. 897).

F. **Ammonia and mercury** in contact have been known to form explosive compounds (Ind. Eng. Chem. News Edition, 1932).

G. **Sodium and potassium scrap** should not be placed in ethanol or methanol for disposal. Reaction with butanol or other high boiling alcohol is better. Adding small increments of ethanol to sodium under toluol, or small increments of water to sodium under kerosene, is also safe. All of these reactions should be carried out in a hood.

H. **Hydroxylamine derivatives**, particularly those related to hydroxamic acid, should be treated as explosive compounds. They should be handled behind screen with a full complement of safety devices.

I. **A new or unfamiliar product** whose stability has not been tested thoroughly or is not known, should not be stored in tightly sealed containers unless absolutely necessary, and in such cases should be examined frequently.

VI. **Chemical Hazards: HF Handling**

A. Rubber gloves should be used whenever HF is handled.

B. The boiling point of anhydrous HF is 20° C. Never use a cylinder of this material unless its temperature is 25° C. or above.

C. If HF is spilled on the floor, it should be neutralized with lime or lime water and flushed with copious amounts of water.

D. Buckets of lime water should be placed at convenient locations in each working area and hands rubbed therein after each exposure to HF.

E. MgO paste should be applied immediately after rinsing wherever HF is known to have come in contact with the skin. Then report directly to the plant hospital.

F. Lines used for transferring anhydrous HF must be allowed to drain and vaporize into a hood before moving or storing. Room temperature of 25° C. or above is essential for rapid evaporation of the remaining HF.

INDEX

Chemical Division General Laboratory Safety Rules



Part I General Plant Safety Rules

Part II Classified

I. Housekeeping	8
II. Safeguards	9
III. Laboratory Chemical Disposal	12
IV. Chemical Hazards: Toxicity	12
V. Chemical Hazards: Fire and Explosion	15
VI. Chemical Hazards: HF Handling	17

CARBIDE AND CARBON CHEMICALS CORPORATION
POST OFFICE BOX P
OAK RIDGE, TENN.

SAFETY BULLETIN NO. 1

CYLINDER STORAGE AND HANDLING

- 1.01 All cylinders shall be stored in warehouses K-1025-A-B-C-D and E and no other materials shall be stored in the same building with these cylinders.
- 1.02 When shipments of cylinders are received the safety cap on each cylinder shall be inspected for evidence of leakage. Loosened caps shall be tightened. Cylinders showing evidence of a white deposit shall be considered as leaking and disposed of in accordance with paragraph 1.12.
- 1.03 One cylinder at a time shall be lifted from the truck by means of the mono-rail hoist. The cylinder shall then be brought inside the warehouse to the center of the main aisle where it shall be weighed and then carried by use of the mono-rail hoist to the point where it is to be stored.
- 1.04 Cylinder storage in each building shall be limited to four piles, two piles in each end of the building with an aisle between. Each pile shall be limited to a base of fifteen (15) cylinders and with four (4) cylinders the maximum height. Cylinder piles shall be started on chocked stringers which are provided.
- 1.05 Where feasible, withdrawal of cylinders shall be limited to a particular building until the stock of cylinders in the building has been exhausted.
- 1.06 Withdrawal of cylinders from active storage shall be a function of the Operating Department and shall be limited to as few persons as possible.
- 1.07 Only thoroughly trained and fully competent personnel should be assigned to the handling of cylinders.
- 1.08 A list of personnel assigned to handling cylinders shall be furnished by the Area Supervisor to the Medical Department who will arrange for the periodic examination of these employees.
- 1.09 When entering buildings where cylinders are stored, operating personnel shall be on the alert for evidence of leaking cylinders. If the building air is difficult to breathe or if there is any evidence of smoke or fog from hydrolysed material, the building shall be closed immediately and not re-entered for ten (10) days.
- 1.10 At the expiration of ten (10) days the building shall be opened by a representative of the Operating Department accompanied by the Area Safety Engineer. If there is no evidence of smoke or fog from hydrolysed material and breathing is not restricted, it shall be considered safe for operating personnel (wearing clothing and protective equipment specified in paragraph 1.17) to enter the building.
- 1.11 The leaking cylinders shall then be located and marked and the interior of the building shall be thoroughly washed with water.

- 1.12 Following washing operations, the leaking cylinders shall be removed to the outside of the building and depressured into water. The leaking valve shall then be replaced with a normal unit or the opening closed with a plug. The cylinder shall then be transported to the process area.
- 1.13 During the depressuring operation, copious amounts of air shall be blown across the cylinder and away from the operator.
- 1.14 Inactive warehouses shall be inspected weekly by the Area Safety Engineer.
- 1.15 When handling contaminated cylinders, all personnel shall wear coveralls and neoprene gloves as minimum protection.
- 1.16 When it is necessary for personnel to enter an area where breathing is difficult due to hydrolysed material, an air supplied mask shall be worn and the legs of coveralls shall be tightly fastened at the ankles.
- 1.17 During the washing down of the interior of a building, all personnel engaged in this operation shall wear 1) neoprene (or rubber) boots, 2) coveralls with legs worn inside of boots, 3) neoprene gloves, and 4) Comfo Respirator (BM-2101 with dust filter BM-2133).
- 1.18 Eating in storage buildings is prohibited. Chewing tobacco, candy, chewing gum, etc. shall not be carried into contaminated areas.
- 1.19 All tools and equipment used in connection with the plugging or revalving of cylinders shall be thoroughly washed in a sodium carbonate solution, following by rinsing with tap water.
- 1.20 All clothing and protective equipment worn by personnel handling cylinders, or working in contaminated areas, shall be returned to the Safety Department.

November 25, 1944

CARBIDE AND CARBON CHEMICALS CORPORATION
OAK RIDGE, TENN.

SAFETY BULLETIN NO. 5.

OPERATION OF SERVICE AND PURGE AND PRODUCT ROOMS.

- 5.01. All non-essential personnel shall be kept out of Service and Purge and Product rooms.
- 5.02. Persons engaged in the manipulation of any valve shall wear neoprene or canvas gloves.
- 5.03. The orifice by-pass in the refrigerant line shall not be opened while the cold trap is above -25°F .
- 5.04. Before disconnecting any portion of the process system, the section of line to be broken shall be evacuated and purged. The section to be broken should be isolated by two valves, preferably with a purge seal between.
- 5.05. Neoprene or canvas gloves shall be worn by those breaking connections or handling equipment, the exposed surfaces of which may be contaminated with process material.
- 5.06. Storage and product drums shall be handled with extreme caution, taking care that they do not bump against other equipment. One product shipping cylinder shall be filled and removed from the pit before another product shipping cylinder is filled.
- 5.07. Each member of the regular operating crew, and each other person whose duties regularly require entry to the Service or Purge and Product room, shall wear attached to his person, when entering such rooms, a U. S. Army Assault Mask.
Each person, other than personnel covered by the above paragraph, shall wear attached to his person, when entering the Service or Purge and Product room, an "All Service" mask equipped with model "S" cannister.
- 5.08. In the event of a leak, each person in the Service or Purge and Product room shall immediately don his mask and leave the room by the nearest exit.
- 5.09. Immediately upon evacuation of personnel from room, the doors and wall louvers shall be closed and the ventilating fans shut down.
- 5.10. Persons shall return to room only to carry out instructions of the foreman, and each person so returning shall wear the protective equipment specified in paragraph 5.14, except that a self contained oxygen breathing unit shall be substituted for the Dustfoe Respirator.
- 5.11. After a settling period of about a half hour to an hour, the ventilating fans shall be turned on and the wall louvers put back on automatic operation. After the atmosphere has cleared, persons wearing the protective equipment specified in paragraph 5.14 shall enter the room for inspection.
- 5.12. Maintenance work shall be deferred until any necessary decontamination of room, as described in paragraph 5.13, has been carried out.

5.13. If any dust has settled out on floor, walls, or equipment, it shall be removed by the minimum number of men consistent with efficient operation, but a minimum of two persons shall always be present in the room, and one outside as precautionary measure. Dust shall be removed by means of an approved type vacuum cleaner. Such decontamination shall be carried out as rapidly as possible.

5.14. Persons engaged in the removal of dust shall wear: (1) Gauntlet type neoprene gloves, (2) Clearvue Dustfoe Respirators (BM 2147 with BM-2148 dust filter), (3) head covering, (4) rubber boots, and (5) special coveralls with legs outside of boots, and tightly fastened at bottom.

5.15. Eating in Service rooms and Purge and Product Rooms is prohibited. Chewing tobacco, candy, chewing gum, lunches, etc., shall not be carried into Service or Purge and Product Rooms.

5.16. All clothing and protective equipment which has been worn in contaminated areas shall be turned over to the Safety Department.

CARBIDE & CARBON CHEMICALS CORPORATION
OAK RIDGE, TENN.

~~RESTRICTED~~

SAFETY BULLETIN NO. 11.

OPERATION OF DEGREASING & PICKLING AREA.

- 11.01 All persons engaged in guiding equipment into or out of tanks shall wear goggles.
- 11.02 Persons handling surfaces wet with any of the liquids used in cleaning shall wear neoprene gloves.
- 11.03 Persons adding acid or alkali to the cleaning tanks from carboys or drums shall wear acid goggles, rubber aprons and neoprene gloves.
- 11.04 Persons adding ammonia to the cleaning tank shall wear a chemical cartridge respirator with GMC cartridge in addition to the protection called for in paragraph (11.03).
- 11.05 In mixing water and concentrated sulfuric acid, the acid shall be added to the water, never the water to the acid.
- 11.06 Material shall be lowered into and removed from the cleaning tank slowly to avoid splashing.
- 11.07 Hot trichlorethylene shall not be sprayed on equipment unless such equipment is below vapor line.
- 11.08 Material being removed from a cleaning tank shall be suspended over the tank until drainage is no more than dropwise. In the case of removal from degreaser, equipment shall be suspended for one minute above the vapor line and below the draft line.
- 11.09 Piping shall be so suspended in slings that drainage will be complete and no liquid will be trapped.
- 11.10 All acid or alkali equipment shall be drained of its contents and thoroughly flushed with water before any work on it is begun.
- 11.11 Rubber, neoprene, or rubber or neoprene covered gloves and acid goggles shall always be worn by persons breaking connections on acid or alkali equipment.
- 11.12 Prolonged breathing of trichlorethylene vapors shall be avoided. A chemical cartridge respirator with GMC cartridge shall be worn in locations where bad spills occur, until atmosphere is cleared.
- 11.13 Persons in the vicinity of trichlorethylene operations shall not smoke.

~~RESTRICTED~~

C8c

SAFETY BULLETIN NO. 11. (cont'd)

~~RESTRICTED~~

OPERATION OF DEGREASING & PICKLING AREA.

- 11.14 No one shall enter the degreaser unless it has been drained, ventilated until free of solvent vapors and declared safe for entry by the ranking supervisor.
- 11.15 The degreaser pit shall not be entered until ventilation equipment has been checked and found to be in operation.
- 11.16 Compressed air hose must not be directed at personnel.

April 26, 1945

~~RESTRICTED~~

GENERAL SAFETY RULES

FERCLEVE CORPORATION

OAK RIDGE, TENNESSEE

GENERAL SAFETY RULES

FERCLEVE CORPORATION

OAK RIDGE, TENNESSEE

TABLE OF CONTENTS

	Page No.
Working Together - Security and Safety:	4
On the Job	5
Off the Job	6
General Rules	7
Protective Equipment	8
Protective Clothing	9
Personal Hygiene	10
Fire Protection	11
Housekeeping	13
Maintenance	14
Hand Tools	15
Ladders	16

TO: ALL FERCLEVE EMPLOYEES

The Fercleve Corporation is a major part of the National War Program, and its continuous SAFE operation is imperative. Every means will be used to safeguard the personnel and the Plant property.

Avoidable conditions are responsible for a large majority of injuries to employees, and any indifference to SAFETY RULES on the part of an employee cannot be excused or condoned.

Safety is imperative; health is essential; and efficiency is the quality most valuable in an employee. Each is dependent upon the other. Safety is not attainable in the absence of good health, nor is it realized by an inefficient worker. Good health depends upon freedom from accident; healthy employees are usually the most efficient.

Those in charge of the operation have the same responsibility for accident prevention as they have for any phase of the work under their direction, and it is to be clearly understood that no job is well done unless the accident record on that particular job is above criticism.

The Management of Ferclve Corporation will welcome any suggestions made by employees in the interests of furthering safety and efficiency in the operation of the Ferclve Plant.

WORKING TOGETHER SECURITY AND SAFETY

Two very important functions must be carried out by Ferclve Corporation according to existing rules and regulations: SECURITY AND SAFETY.

You are honor bound as a loyal American to observe all Security rules of C. E. W. and S-50 Area. You must, for your own self-preservation, while on or off the job, follow safety rules as set out in your Hand Book.

The Jap-Nazi spy system is desperately interested in all information about important American war work. Any bits of information about this job may help them piece together the size, scope, nature, purpose, progress of this project. Unnecessary talking or writing may unintentionally help the enemy know the character and status of the work, as well as the location and importance of facilities or equipment. Refraining from talking and writing about the Project except when author-

ized to do so as part of your job is a "must" in our effort to stop highly trained enemy agents from successfully attacking our country from within.

To make this job really count, remember the following commonsense rules:

ON THE JOB

PROTECT all Project equipment, facilities, material and information.

REPORT any unauthorized persons in your section seeking information about your job.

KNOW only your job. Curiosity about this Project beyond your own part in it is dangerous, unnecessary, and may lead you to violate security regulations. If you need to know, you will be told.

WEAR identification badges in plain sight at all times while on the Project.

SPIKE rumors and gossip about the job. The confusion, fear, slow ing-up of work resulting from rumors are unnecessary. Be on guard! Rumors "may be made in Japan."

TALK AND WRITE about the job

ONLY when it is your responsibility to do so.

TEST: "Is telling or writing this necessary?"

REPORT all persons who shirk their security duty. You may help them help the enemy if you don't.

OFF THE JOB

PROTECT all Project information when in buses, trains, stores, meetings, and with neighbors.

REFRAIN from giving Project information to members of your family or others not specifically authorized.

AVOID discussing the Project with other project workers even though they are from your own section.

THINK before you write! Bits of information about the Project may get loose if you forget your security duty. **THINK OF SECURITY AT ALL TIMES.**

GENERAL RULES

1. Employees are allowed in the Plant only at such times, and in such buildings, as their plant badges permit, and then only in such departments as their duties require.
2. Enter and leave the Plant Area only by the gate designated; namely, the gate on the Ferclève Road.
3. Employees are requested to read and observe bulletin board material and other printed safety notices.
4. Private cars shall be parked in designated areas only; and when driven through the Plant Area, shall not exceed the speed of 10 M. P. H.
5. Horse play is prohibited at all times.
6. No running is permitted in buildings or in yards.
7. No employee will be permitted to report for work under the influence of liquor.
Any infraction of this rule will subject those concerned to immediate dismissal.
8. Every employee should report promptly to his foreman any condition affecting the safety of himself or of a

fellow employee.

9. Create no nuisance. Be clean and help keep the Plant clean.

PROTECTIVE EQUIPMENT

1. Appropriate protective equipment will be made available to all personnel whose duties require its use. The proper application and use of this equipment must be followed.
2. Unless otherwise shielded at the machine or source, employees who are performing work which involves danger of eye injury must wear approved goggles, safety spectacles.
3. Approved respiratory equipment must be worn when employees perform work involving that type of hazard.
4. Ferclève employees can expect properly fitted, clean, sterilized goggles or respirators, with straps for fastening same, at all times. Report them if found to be otherwise.
5. Gloves must not be worn when working on machinery while in motion. Rubber gloves should be worn when handling acids.
6. Always wear a safety belt when working in high places.

7. Neckties should never be worn by machine operators or others who come in contact with moving machinery.

8. The wearing of finger rings is forbidden. Safety shoes are recommended. Goggles must be worn when:

- a. Working with acids
- b. Dry grinding
- c. Chipping
- d. Welding or pouring molten metal
- e. "Busting" concrete, rivets, etc.
- f. When blowing chips, drilling, etc., from castings or machinery
- g. Doing all other work where there is a possibility of eye injury.

PROTECTIVE CLOTHING

1. Employees working in the Process Area must wear two layers of clothing:

- a. One layer will consist of long underclothing
- b. The second layer will consist of coveralls.

2. This clothing will be issued from the Change House, and is to be turned in there for laundering once a week.

3. Neo-prene gloves are provided for all employees handling acids. Asbestos gloves are available to all employees handling "dry ice."

4. Hard hats are furnished all employees working in the Process Building, and persons who work therein are expected to wear them when in the building.

5. Employees working in operations should take care to see that the soles of their shoes are in good condition. This will insure greater protection against corrosive chemicals.

6. The sleeves and trouser legs should be closely fastened at the wrists and ankles.

PERSONAL HYGIENE

1. Personal cleanliness is an important factor in maintaining the health standards of this Plant. All employees working in operations are required to bathe thoroughly at the end of each shift.

2. Work clothes are to be left in the Change House at the end of your shift. Never wear your work clothes home.

3. All employees should wash their hands thoroughly before eating any food.

4. No food is to be eaten in the Process building at any time.

5. Employees working in the Process Area should exercise great care when smoking, so as not to contaminate the mouth with any material which might be on their hands.

6. It is advisable not to carry candy, gum, and tobacco in one's work clothes in order to prevent contamination from the material.

FIRE PROTECTION

1. Every employee must ascertain the location of fire-fighting apparatus within his work area, such as fire pails, sand pails, hose coils, chemical fire extinguishers, etc., and acquaint himself with the instructions provided.

2. Fire-fighting apparatus must not be used for purposes other than fire fighting.

3. Thoroughly acquaint yourself with the safety exits of the building in which you are employed, the location of automatic sprays, and the nearest alarm box or telephone, which are to be used in case of emergency. In such cases, it is important that you state exactly where the fire is and its nature.

4. Employees are required to take part in all fire drills in the area of their employment, remembering to use judgment and to be orderly at all times to avoid panic or confusion.

5. You must become informed regarding calls and signals to be used in case of an emergency. Ask your foreman.

6. Dirty clothes, paper, oily waste, refuse and inflammable material must be placed in approved metal receptacles. One type of receptacle is provided for hazardous waste and another for miscellaneous waste.

7. Any unsafe condition of tools, buildings or equipment should be reported promptly to your foreman or other responsible official.

8. Any material unnecessary to operations shall not be allowed to remain in the Process Area.

HOUSEKEEPING

1. One of the most important factors in accident prevention is good housekeeping. The careful employee will keep his workplace clean and orderly; he will clean up as he goes, inasmuch as loose articles or spilled materials constitute a tripping or slipping hazard, and indicate slovenly, as well as careless, operation.
2. All buildings must be kept clean and especial care given to those in which inflammables are stored.
3. In maintaining a clean Plant, dust accumulation on pipes and structural ledges, as well as on equipment, must not be overlooked. It is necessary, therefore, to look up and all around when cleaning. In addition, regular cleaning crews will periodically clean places not ordinarily accessible to regular employees.
4. Maintenance employees are responsible for cleaning up after making repairs. This will include removal of tools, material and accumulated debris.
5. Lockers must be kept clean. Locker rooms, wash rooms and working areas must be maintained in sanitary and

orderly condition.

MAINTENANCE

1. All repairs and changes in electrical equipment must be made by persons authorized to do this work. Never attempt to adjust electrical or other equipment by yourself.
2. All employees must recognize and respect any danger warning, card or sign used by the Maintenance Department while making repairs to mechanical equipment.
3. No extension cord or other device will be plugged into any circuit unless under the direction of the foreman, and then only when the switch is in an OFF position.
4. Before repairs are made on any power-operated or electrical equipment, the switch controlling the Circuit must first be turned off, and locked by a member of the Maintenance crew, who should retain the key until proper repairs have been made.
5. Maintenance men should not attempt any repairs on the Process Units until all steam valves have been turned off and so designated by the

Steam Department.

6. Maintenance or Operations men should never open or close any steam valve without contacting the Steam Department first.

7. Do not look at arc welding as it will cause sore eyes. Gas welding equipment must not be used or tampered with by anyone but an authorized operator.

HAND TOOLS

1. Mushroomed heads, burred heads, split, broken or loose handles on hand tools are dangerous. Exchange such tools or have them repaired.

2. Be sure your wrench fits properly. Do not use a shim to fill up space around a nut or bolt head. Get a proper fitting wrench and avoid wrenches with battered jaws.

3. It is dangerous to yourself and to others to carry in your hip pocket sharp edged tools such as chisels, screw drivers, etc.

4. Never use a tool in such a way that if the tool should slip, it could injure your hands or body.

5. Soft metal hammers should be used for striking tempered or case hardened tools and material.

6. Keep crow bars sharpened and in good condition. Get good footing and watch the placement of your hands when using a crowbar. Always be prepared should the bar slip.

7. Always remove handles from jacks.

8. When using hand shears, be careful your fingers are not in a position to be pinched between the stop lug on the handles.

LADDERS

1. Never use a ladder which is defective in any respect, such as one with broken or split side rails or rungs, or with dull or loose safety feet.

2. In placing ladders, be sure to lean them at the proper angle so they cannot fall backwards or slip out at the bottom.

3. When using ladders with spiked feet on concrete floors, use boards under the spikes.

4. When using ladders on slippery wood block floors, be sure the spikes

are sharp.

5. Never lean a ladder against a running shaft or pulley or against an unsafe backing such as loose boxes, barrels or round objects.

6. To carry boxes, tools, chainfalls or other material in your hands when climbing or descending a ladder is a dangerous practice. Use a rope so that both hands will be free to grasp the ladder.

7. Avoid working with another man on the same ladder.

8. Never place a ladder so that the feet of the ladder are on boxes, kegs, trucks or other movable objects.

9. Ladders should never be spliced together, nor should cracked stringers be wired or nailed.

10. Ladders should be provided with boards across the top before being placed against window frames.

11. Except for special purposes, never use home-made ladders and then only when such use is authorized by foreman.

12. When using ladders on roofs or

on other high places, tie them so that they cannot possibly slip.

13. Report all defective ladders to your foreman, who will see that they are replaced and destroyed .

As a War Worker, you are playing just as necessary and important a role in the successful conduct of the war as do our soldiers on the battlefields. Every day preventable industrial accidents are delaying, or denying entirely, the providing of our military forces with supplies imperative to our cause. They are costing us essential manpower. Sometimes the loss is a few days, sometimes many. The loss is always a setback to our war effort. The sad thing about it is that, according to generally accepted figures, only 2% of all accidents are really preventable.

Safety is, therefore, an individual responsibility -- a responsibility which you owe, not only to yourself and your fellow workers, but to those in uniform abroad, depending on your production. The worker who is protecting himself by practicing safety is protecting his country.

FERCLEVE CORPORATION

Date _____

I have read and I understand all the rules contained in the "Safety Rules and Regulations" booklet and I will carry out these rules to the best of my ability and do everything possible to prevent injury to myself and my fellow workmen.

Signed _____
Employee

Badge No. _____

Department _____

Signed _____
Foreman

RETURN TO SAFETY
DEPARTMENT

February 23, 1945

To: All Division, Staff and Department Heads
From: R. T. Barnett
Subject: Requirements for Moving Heavy Equipment

1. The following regulations shall be strictly adhered to by all departments moving heavy equipment:
 - (a) The supervisor should survey the route to be used and ascertain the condition of bridges, culverts, turning radii, and overhead wires.
 - (b) Proper flagging consisting of a fixed flag on each corner of the equipment and a flag on any protruding objects such as timbers or crane boom. For night movement, red lights should be used in place of flags.
 - (c) Slow moving equipment, caterpillar treads, shall have at least one flagman for the purpose of flagging traffic. Red flags shall be used for this purpose during daylight hours. Red lanterns during hours of darkness.
 - (d) A foreman, or responsible supervisor, shall be present and in charge while the equipment is in travel.
 - (e) Fast moving rubber tired equipment such as truck cranes, do not necessarily need to be preceded or followed by a flagman on foot. Additional markings on the truck crane are suggested, such as, the sheave block boom tip and counter balance being black and white striped.
 - (f) All equipment extending 15' or more above the road surface shall be accompanied by a competent electrician with hot-sticks to raise any overhead wires. A man should be so posted that he is able to watch for any overhead obstructions.
 - (g) Rubber tired vehicles, when towing equipment not fitted with rubber tires shall not exceed a speed of 15 M.P.H.
 - (h) All overhead obstructions clearing less than 18' which are encountered shall be reported to the Safety Department.
2. All overhead obstructions on the Area clearing less than 18' shall be marked with warning signs with the clearance marked thereon.

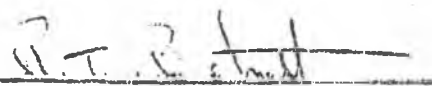
R. T. Barnett
Safety Director

APPROVED BY

Ass't Project Manager

C O P Y

MONTHLY SUMMARY OF SAFETY ACTIVITIES

Tennessee Eastman Corporation

March 1945

Organization.

The safety department has completed a few of the anticipated changes mentioned in the February report.

Mr. Arnold Higdon, assigned to mechanical safety engineering.
Mr. Raymond Stewart, assigned buildings 9201 -4 and -5.
Mr. P. C. Ziemske is handling crane and elevator inspections.
Dr. Gustav Strebel, Optometrist, has been employed by the Medical Division and is organizing the goggle protection program.

A clerk is being trained by the safety department and will work in the hospital to handle the bulk of the accident reporting required by the insurance carrier. It is estimated that the full time of two safety men will be saved by obtaining this "on the spot" information.

The steam and cooling division has issued a schedule of boiler inspections. The U.S.E.D. Safety Branch has transmitted correspondence regarding compliance with regulations set forth in District Circular Letter (Safety 45-1).

Mr. J. M. Brown, T.E.C. Safety Director, has not been successful to date in employing an inspector for pressure vessels.

Injury Rates - March 1945.

Frequency - 2.64
Severity - 0.03

These are the lowest accident rates in the history of TEC, C.E.W. operations. The safety department in particular and everyone who contributed to this record deserves a word of commendation.

Training.

A special training class in chemical safety will begin on April 16th. The course will consist of two one-hour sessions for each employee concerned and will reach about 350 employees.

Mechanical Inspections and Improvements.

A standard method of painting pipe lines has been devised and submitted to management for approval. T.E.C. safety department is now

studying the possibility of adding a standardized identification to pressure vessels and cylinders.

A list of recurring safety items is being compiled with the estimated needed inventory and ordering dates which will eliminate the shortages of equipment and material now experienced.

The T.E.C. safety department will make a study of portable and hand tool maintenance when personnel is available to make the study.

Recommendations.

The U.S.E.D. Safety Branch feels that the program would be aided by:

The addition of medical personnel to offer 24 hour service within the T.E.C. Area. The number of personnel on the second and third shifts warrants this additional coverage.

The safety department should have an opportunity to review and advise on equipment and materials of a safety nature. An arrangement to facilitate this service should be made with the engineering, purchasing and safety departments.

An inspection made in building 9709 showed need for so many improvements that consideration should be given to a complete revamping of the layout and equipment. If this is accepted as a solution to the problem the safety department should be given an opportunity to review plans of revision before the work is carried out.

While some parts of building 9201-4 are in excellent condition the mechanical servicing section is unsettled and a change in production method is planned. After this industrial engineering is completed, or in conjunction with same, a safety engineering survey covering brasing, welding, and testing in the docks should be made.

Prepared by:
Safety and Accident Prevention Branch
U. S. E. D.
17 April 1945.

MAY 1945

CARBIDE AND CARBON CHEMICALS CORPORATION

1. Statistical Review.

The frequency rate of 11.25 established for May represents the highest Carbide rate since September 1944. The number of lost-time injuries increased from 11 in April to 24 in May. The Carbide frequency rate may be compared with the CEW operating contractor frequency rate as follows:

Month	Carbide Frequency Rate	Combined CEW Operating Contractor Frequency Rates \mp Exclusive of Carbide	Combined CEW Operating Contractor Frequency Rates - Including Carbide
Sept. 1944	15.36	5.89	6.58
Oct. 1944	6.91	5.78	5.88
Nov. 1944	8.95	6.79	7.00
Dec. 1944	10.85	5.91	6.35
Jan. 1945	8.59	7.59	7.70
Feb. 1945	7.17	8.22	8.07
Mar. 1945	8.99	4.26	4.66
Apr. 1945	6.81	7.46	7.34
May 1945	11.25	6.79	7.86

2. Personnel.

The Safety Supervisor advises that there were approximately 57 employees in the Safety Section during the past month.

Within the inspection unit of the section a major change in assignments has taken place. Area Engineers are now assigned on the basis of divisions rather than geographical areas. Mr. Cross henceforth will advise the Process and Power House Divisions; Mr. Smothers will advise the Maintenance and Equipment Test and Inspection Divisions; and Mr. Hudson will advise all others - Industrial Relations, Laboratories, Plant Protection, Manufacturing and Plant Engineering.

The Safety Supervisor advises that a new organization chart reflecting this and other changes will be prepared in the near future.

3. Plant Organization for Safety.

The high frequency rate established during the past month effectively indicates three significant points:

- a. A serious safety problem does exist.
- b. The problem apparently is created by "routine hazards" rather than the "special hazards," on which unusual emphasis has been placed.

~~CONFIDENTIAL~~

~~CONFIDENTIAL~~

- c. A permanent reduction in frequency probably will not be accomplished until all Supervision becomes aware of its responsibility for safety as assigned by plant management and the Central Safety Committee, and the over-all plant safety program is introduced and begins to function. Responsibility for safety has now been properly placed and the need for a large safety department which formerly assumed many safety responsibilities of supervision no longer exists.

During the past month the first Central Safety Committee meeting was held. Plans have been formulated for Divisional Safety Committee meetings to be held prior to the next Central Safety Committee meeting. The Training Department has taken over the phases of employee training formerly handled by the Safety Department and has agreed to devote one supervisory meeting a month to safety.

4. Reporting Procedures.

During the past month, delay continued to be experienced in receipt of the Individual Injury Report (W.D., A.G.O. Form No. 501). It is anticipated, however, that with the institution of the new reporting procedures, all delays should be eliminated after 1 June 1945, and the reports should become current. The new system will require the Medical Department to apprise the Safety Department by telephone of all fatalities, critical injuries, potential lost-time cases, cases involving exposure to process material, and others of unusual significance. All other cases will be noted by the Medical Department on standard forms to be picked up by the Safety Department at regular intervals. Upon receipt of notification of injury (either by telephone or standard form), the Safety Department prepares an "Accident Report" form which is forwarded immediately by messenger to the Division concerned for investigation. Within each Division a coordinator has been appointed by the Division Superintendent to distribute the reports to the proper supervisor for investigation. In addition, the Safety Department initiates separate investigations in lost-time cases and others of particular significance.

5. Physical Hazards.

Considerable attention should be given to the correction of the numerous unsafe physical conditions within the plant. It is axiomatic in organized safety work that unsafe physical conditions must be eliminated first to convince employees of management's interest in their safety. This having been accomplished, an intensive campaign can then be directed toward the elimination of unsafe acts - which, on a national basis, are considered responsible for four times as many injuries as unsafe conditions.

6. Safety Equipment.

Upon recommendation of the Central Safety Committee, formal

~~CONFIDENTIAL~~

~~CONFIDENTIAL~~

action has been taken to relieve the Safety Department of all equipment issue, excepting shoes and goggles, by 11 June 1945. Safety equipment issue after that date will be accomplished through the tool cribs whose stock of safety equipment will be maintained in accordance with a list recommended by the Safety Department.

The Safety Supervisor advises that a survey is in progress to determine those jobs and areas where the use of safety goggles shall be made mandatory. In view of the large number of eye injuries, it is recommended that the use of goggles immediately be made mandatory for all metal-working and wood-working machine operators in accordance with recognized national safety standards and U. S. Engineer Department "Safety Requirements."

7. Miscellaneous.

a. Driver Training. Statistics developed by the Office, Chief of Engineers, indicates that, on a nation-wide basis, over 30% of all drivers subjected to the new Corps of Engineers driver's examination (which will be introduced on the Area on 1 July 1945) fail to pass if they have not been subjected to driver training. This condition was referred to the Industrial Relations Supervisor for his consideration. At his direction, a driver training program supervised by the Training Department (and developed by coordination effected between the Safety, Medical and Training Departments) will be instituted on or about 1 July 1945.

b. Bulletins. Safety Bulletins which have appeared since the last summary include:

Safety Bulletin No. 13 - Evacuation Procedure for the Conditioning Area (Furnace Room and Basement)

Safety Bulletin No. 14 - Dumping Carbon Traps.

Safety Bulletin No. 15 - Entering Cell Enclosures.

8. Summary.

During the past month a considerable rise in frequency was experienced. This might be expected until such time as the organized plant safety program is placed in full operation and all supervision becomes fully aware of its responsibility in the program. Placing safety responsibility with supervision is proper, and it eliminates the need for a large safety department which formerly assumed many of the responsibilities. The first Central Safety Committee meeting was held and plans were formulated for extending the committee system throughout the plant. Receipt of reports continued to be delayed, but a new procedure should make the reporting system current without further delay. A new detailed accident investigation procedure has been instituted. Plans have been made to transfer safety equip-

~~CONFIDENTIAL~~

~~CONFIDENTIAL~~

ment issue, excepting goggles and shoes, to the tool cribs. The correction of physical hazards progresses at a relatively slow rate, enforcement of the use of goggles is still lacking and a concentrated publicity program has not yet developed. It might be said that the period was characterized by a partial transition of the plant safety program to the principles approved by the Central Safety Committee.

Prepared by:
Safety and Accident Prevention Branch,
Manhattan District,
14 June 1945.

~~CONFIDENTIAL~~

C O P Y



ARMY SERVICE FORCES
UNITED STATES ENGINEER OFFICE
MANHATTAN DISTRICT
OAK RIDGE, TENNESSEE

REPLY
R TO EIDMQ-5
729.3

20 April 1945.

Subject: Monthly Report of Facilities Activities, 1 March to 31 March
1945, Roane Anderson Company.

Memorandum To: Major E. J. Bloch.

1. On 19 April 1945 the undersigned met with R. T. Bartnett and W. J. Enders of the Roane Anderson Company safety department, and M. E. Ridge and W. S. Rasmussen of this Branch, to discuss the safety department of the subject company.
2. Mr. Bartnett was told that this Branch did not consider the items listed in paragraph 7 of the report ("Five outstanding safety problems") as outstanding safety problems of the Roane Anderson Company.
3. Mr. Bartnett stated that he had interpreted "outstanding problems" to mean only those problems which he was not able to solve by himself.
4. He was informed that this Branch desired a listing of the problems that were of the greatest significance to the safety program, regardless of how they would have to be solved, which would result in improvement of safety for the largest number of employees.
5. It is the opinion of this Branch that some of the problems listed are not responsibilities of the Roane Anderson Company; and, that if all the problems listed were solved, there would be no material change in the overall safety program.
6. Some problems that this Branch considers outstanding are:
 - a. Safety recommendations are not promptly complied with, (387 pending as of 31 March 1945, from previous reports).
 - b. An adequate safety training program has not been instituted as of this date.
 - c. Supervision has not been furnished adequate safety instructions and regulations, as of this date, to serve as a guide in its safety responsibilities.

d. Two large departments have safety performances considerably below par for the company as a whole.

e. An accident reporting system has not been established that will furnish all the statistical information that could be used to advantage in accident prevention.

JAMES R. MADDY,
District Safety Engineer.

**TRAFFIC
REGULATIONS**

FOR

**Clinton
Engineer
Works**

OAK RIDGE, TENNESSEE

The following traffic regulations shall govern the operation of vehicles at Clinton Engineer Works:

ARTICLE I

TRAFFIC CONTROL DEVICES

Sec. 1. OFFICIAL TRAFFIC CONTROL DEVICES. (a) The driver of any vehicle shall obey the indications of all official traffic control devices applicable thereto, unless otherwise directed by a police guard.

(b) The obedience to all traffic control signs, signals, and markings shall include:

- (1) Observance of all speed limits.
- (2) Observance of all regulatory signs; stop, slow, school, playground, etc., which can be ascertained by their yellow background.
- (3) Observance of all direction signs placed to aid the expeditious movement of vehicular traffic.

(c) No provision of these regulations for which signs are required shall apply against an alleged violator if at the time and place of the alleged violation an official sign is not in proper position and sufficiently legible to be seen by an ordinarily observant person.

Sec. 2. NO-TURN SIGNS AND TURNING MARKERS. Whenever authorized signs are erected indicating that no right, left or "U" turn is permitted, no driver of a vehicle shall disobey the direc-

tions of any such sign. When authorized marks, buttons, or other indications are placed within an intersection indicating the course to be travelled by vehicles turning thereat, no driver of a vehicle shall disobey the directions of such indications.

Sec. 3. ZONE OF QUIET. Whenever authorized signs are erected indicating a zone of quiet, no person operating a motor vehicle within any such zone shall sound the horn or other warning device of said vehicle except in an emergency.

Sec. 4. PLAY STREETS. Whenever authorized signs are erected indicating any street or part thereof as a play street, no person shall drive a vehicle upon any such street or portion thereof except drivers of vehicles having business or whose residences are within such closed area, and then any said driver shall exercise the greatest care in driving upon said street or portion thereof.

ARTICLE 2

STOPPING, STANDING, AND PARKING

Sec. 5. SIGNS PROHIBITING PARKING. When official signs prohibiting parking are erected on any street or portion thereof, no vehicles shall be parked in any such designated place.

Sec. 6. PARKING PROHIBITED IN CERTAIN PLACES. (a) No person shall stop, stand, or park any vehicle upon a street, in such a manner or under such conditions as to leave available less than ten feet of the width of the roadway for free movement

of vehicular traffic, except that a driver may stop temporarily during the actual loading or unloading of passengers, or when necessary in obedience to traffic regulations or traffic signs or signals or a police guard.

- (b) No person shall stop, stand, or park a vehicle, except when necessary to avoid conflict with other traffic or in compliance with the directions of a police guard or traffic control device, in any of the following places:
- (1) On a sidewalk.
 - (2) Within an intersection.
 - (3) Within 15 feet of a fire hydrant.
 - (4) On a crosswalk.
 - (5) Within 20 feet of a crosswalk at an intersection.
 - (6) Within 30 feet upon the approach of any flashing beacon, stop sign, or traffic-control signal located at the side of a roadway.
 - (7) Between a safety zone and the adjacent curb or within 30 feet of points on the curb immediately opposite the ends of a safety zone, unless a different length is indicated by official signs or markings.
 - (8) Within 50 feet of the nearest rail of a railroad grade crossing.
 - (9) Within 20 feet of the driveway entrance to any fire station and on the side of a street opposite the entrance to any fire station within 75 feet of said entrance when properly sign-posted.
 - (10) Alongside or opposite any street excavation or obstruction when such stopping,

standing, or parking would obstruct traffic.

- (11) On the roadway side of any vehicle stopped or parked at the edge or curb of a street.
- (12) Upon any bridge or other elevated structure upon a road.

Sec. 7. PARKING PROHIBITED AT ALL TIMES IN DESIGNATED PLACES. When signs are erected giving notice thereof, no person shall park a vehicle at any time upon any of the streets or roads so designated.

Sec. 8. PARKING TIME LIMITED IN DESIGNATED PLACES. When signs are erected in each block giving notice thereof, no person shall park a vehicle for periods of time longer than specified.

Sec. 9. STANDING FOR LOADING ONLY.

(a) No person shall stop, stand, or park a vehicle for any purpose or period of time other than for the expeditious loading or unloading of passengers in any place marked as a passenger loading zone during the hours when the regulations applicable to such passenger loading zone are effective, and then only for a period not to exceed three minutes.

(b) No person shall stop, stand, or park a vehicle for any purpose or length of time other than for the expeditious unloading and delivery or pickup and loading of materials in any place marked as a loading zone during hours when the provisions applicable to such loading zones are in effect. In no case shall the stop for loading and unloading of materials exceed thirty minutes.

Sec. 10. BUS STOPS. (a) The driver of a bus shall not stand or park upon any street in any business district at any place other than at a bus stop, except that this provision shall not prevent the driver of any such vehicle from temporarily stopping in accordance with other stopping regulations

(b) No person shall stop, stand, or park a vehicle other than a bus in a bus stop, when any such stop has been officially designated and appropriately signed, except that the driver of a passenger vehicle may temporarily stop therein for the purpose of and while actually engaged in loading or unloading passengers when such stopping does not interfere with any bus about to enter such zone.

Sec. 11. STANDING OR PARKING CLOSE TO CURB. No person shall stand or park a vehicle in a roadway other than parallel with the edge of the roadway, headed in the direction of traffic, and with the curb-side wheels of the vehicle within 12 inches of the edge of the roadway, except as provided in the following paragraphs:

(a) Upon those streets which have been marked or signed for angle parking, vehicles shall be parked at the angle to the curb indicated by such mark or sign.

(b) In places where and at hours when stopping for the loading or unloading of merchandise or materials is permitted.

Sec. 12. UNLAWFUL PARKING. No person shall stand or park a vehicle upon any roadway for the principal purpose of:

(a) Displaying it for sale.

(b) Washing, greasing or repairing such vehicle except repairs necessitated by an emergency.

Sec. 13. BLOCKING DRIVEWAYS OR GARAGES. No person shall stand or park any vehicle in such a manner as to block ingress or egress from any public or private driveway or garage.

ARTICLE 3

OPERATION OF VEHICLES

Sec. 14. STOP BEFORE ENTERING A THROUGH STREET. Those streets and parts of streets so designated by proper signs are declared to be THROUGH STREETS.

When stop signs are erected upon roadways intersecting a through street at the entrances thereto or at the entrance to any intersection, every driver of a vehicle shall stop at every such sign before entering the intersection except when directed to proceed by a police guard or traffic control signal.

Sec. 15. STOP WHEN TRAFFIC OBSTRUCTED. No driver shall enter an intersection or a marked cross-walk unless there is sufficient space on the other side of the intersection or cross-walk to accommodate the vehicle he is operating without obstructing the passage of other vehicles or pedestrians, notwithstanding any traffic control signal indication to proceed.

Sec. 16. ONE-WAY STREETS. Upon these streets and parts of streets designated by proper

signs, vehicular traffic shall move only in the designated direction when signs indicating the direction of traffic are erected and maintained at every intersection where movement in the opposite direction is prohibited.

Sec. 17. LIMITATIONS ON TURNING AROUND. The driver of any vehicle shall turn such vehicle to the left upon any street in any business district for the purpose of proceeding in the opposite direction or for the purpose of turning along a curb.

Sec. 18. LIMITATIONS IN BACKING UP. The driver of a vehicle shall not back the same at an intersection or over a cross-walk and shall not back at any event or at any place back a vehicle unless movement can be made in safety.

Sec. 19. EMERGING FROM ALLEY OR DRIVEWAY. The driver of a vehicle emerging from an alley, driveway, or building shall stop such vehicle immediately prior to driving onto the sidewalk or into the sidewalk area extending along any alleyway, and upon entering the roadway shall yield the right-of-way to all vehicles approaching from the said roadway.

Sec. 20. VEHICLES NOT TO BE DRIVEN ON SIDEWALK. No driver of a vehicle shall drive within any sidewalk area except at a permanent or temporary driveway.

Sec. 21. VEHICLES NOT TO BE DRIVEN ON CLOSED STREETS. No driver of any vehicle shall drive on a closed street except an authorized emergency vehicle while

in emergency duty, shall drive such vehicle upon any street or roadway which is officially closed to traffic and which is plainly indicated as such by officially erected signs, barricades, or other traffic control devices.

Sec. 22. ONE VEHICLE TOWING ANOTHER

(a) No motor vehicle shall be towed upon any street or roadway if the drawbar or connection exceeds eight (8) feet from one vehicle to the other.

(b) Any vehicle being towed upon any street during a period between sunset and sunrise shall maintain lights on both sides and rear thereof, visible to the rear and on both sides for a distance of not less than two hundred (200) feet.

Sec. 23. EMERGENCY VEHICLES. A driver when operating an emergency vehicle, except when otherwise directed by a police guard, may

(a) Park or stand notwithstanding the provisions of these regulations.

(b) Proceed past a stop signal or stop sign, but only after slowing down as may be necessary for safe operation.

(c) Exceed the speed limits if not endangering life or property.

(d) Disregard regulations governing direction of movement, turns, or construction roads so long as he does not endanger life or property.

All drivers of vehicles shall render right-of-way to emergency vehicles and when hearing the approach of an emergency vehicle shall pull their

vehicles to the furthest right side of roadway and STOP.

Sec. 24. PASSING SCHOOL BUSES STOPPED FOR CHILDREN. No vehicle shall pass any school bus which is stopped to load or unload school children. This regulation requires vehicles to stop regardless of whether they are approaching the school bus from the rear or are meeting it.

Sec. 25. USE OF COASTERS, ROLLER SKATES, AND SIMILAR DEVICES RESTRICTED. No person upon roller skates, or riding in or by means of any coaster, toy vehicle, or similar device, shall go upon any roadway except while crossing a street on a cross-walk and except upon streets set aside as play streets.

Sec. 26. PASSENGERS IN VEHICLES. No person shall ride on any vehicle or any portion thereof not designed or intended for the use of passengers.

Sec. 27. BOARDING OR ALIGHTING FROM VEHICLES. No person shall board or alight from any vehicle while such vehicle is in motion.

Sec. 28. TRAFFIC NOT TO BE OBSTRUCTED. No vehicle, shall be operated or allowed to remain upon any street in such a manner as to form an unreasonable obstruction to traffic thereon.

Sec. 29. TRAFFIC LAWS APPLY TO PERSONS RIDING BICYCLES. Every person riding a bicycle upon a roadway shall be subject to all traffic regulations.

ARTICLE 4
PEDESTRIANS

Sec. 30. PEDESTRIANS SUBJECT TO TRAFFIC CONTROL SIGNALS. Pedestrians shall be subject to traffic control signals at intersections.

Sec. 31. PEDESTRIANS CROSSING AT OTHER THAN CROSS-WALKS. Every pedestrian crossing a roadway at any point other than at a cross-walk shall yield the right-of-way to all vehicles upon the roadway.

Sec. 32. PEDESTRIANS SOLICITING RIDES. No person shall stand in a roadway for the purpose of soliciting a ride from the driver of any private vehicle.

Sec. 33. PEDESTRIANS WALKING ON HIGHWAYS. It is the duty of all persons walking along and upon improved streets or roadways to keep on the left side of the paved portion, or on the left shoulder thereof, and upon meeting a vehicle when walking on the said paved portion to step off to the left.

INDEX

	Section
Blocking Driveways or Garages.....	13
Boarding or Alighting from Vehicles.....	27
Bus Stops.....	10
Emerging from Alley or Private Driveway.....	19
Emergency Vehicles.....	23
Limitations in Backing.....	18
Limitations on Turning Around.....	17
No-Turn Signs and Turning Markers.....	2
Official Traffic Control Devices.....	1
One Vehicle Towing Another.....	22
One-Way Streets.....	16
Parking Prohibited at All Times in Designated Places.....	7
Parking Prohibited in Certain Places.....	6
Parking Time Limited in Designated Places.....	8
Passengers in Vehicles.....	26
Passing School Busses Stopped for Children.....	24
Pedestrians Crossing at Other Than Cross-Walks.....	31

Pedestrians Soliciting Rides.....	82
Pedestrians Subject to Traffic Control Signals	30
Pedestrians Walking on Highways.....	33
Play Streets.....	4
Signs Prohibiting Parking.....	5
Standing for Loading Only.....	9
Standing or Parking Close to Curb.....	11
Stop Before Entering a Through Street.....	14
Stop When Traffic Obstructed.....	15
Traffic Laws Apply to Persons Riding Bicycles	29
Traffic Not to Be Obstructed.....	28
Unlawful Parking.....	12
Use of Coasters, Roller Skates, and Similar Devices Restricted	25
Vehicles Not to Be Driven on Closed Streets...	21
Vehicles Not to Be Driven on Sidewalk.....	20
Zone of Quiet.....	3

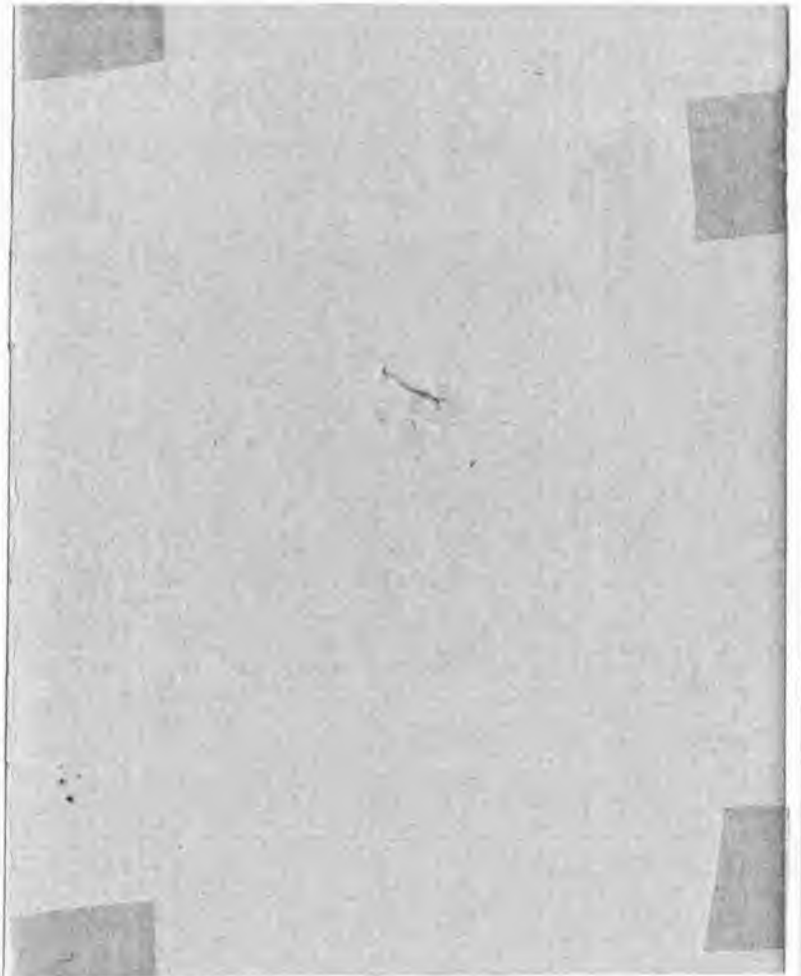



~~CONFIDENTIAL~~

Safety Training

DEC 14 44 PM
1944

RECEIVED

NATIONAL SAFETY COUNCIL

INCORPORATED
20 NORTH WACKER DRIVE
CHICAGO 6, ILLINOIS

CLASSIFIED FILE
U. S. ENGINEER OFFICE
MANHATTAN DISTRICT

21618

Col. K. D. Nichols
District Engineer
U. S. Engineer Office
Clinton Engineer Works
Box E
Oak Ridge, Tenn.

December
Nine
1944

Dear Colonel:

Enclosed herewith is our second Progress and Supplementary Report to the Consolidated Report on a community safety program for the Hanford Engineer Works.

The work done in safety on both projects has and will be invaluable. Persons living on them will make the job of "selling" safety throughout the country much easier when, after the war, they return to their respective cities.

Again, it is sincerely hoped that the staff of the National Safety Council may continue to be of service to the U. S. Engineers.

Eight of the ten typewritten copies are enclosed. Two copies will be kept at our office. You may be assured that the contents will be kept in strict confidence.

Sincerely yours,
Ned H. Dearborn
Ned H. Dearborn
President

MHD/cw
enc.

Classification ~~_____~~ or changed to *Conf.*
by *wjg*

~~CONFIDENTIAL~~



C O P Y



**ARMY SERVICE FORCES
UNITED STATES ENGINEER OFFICE
MANHATTAN DISTRICT
OAK RIDGE, TENNESSEE**

IN REPLY
REFER TO EIDM O-42
729.3

26 November 1943

Colonel John Stilwell,
President, National Safety Council,
20 North Wacker Drive,
Chicago, Illinois.

Dear Colonel Stilwell:

We have been awaiting receipt of the final report, "Community Safety Program" and are pleased to have it.

Many preliminary recommendations of the Council's staff experts have already been put to work and it is anticipated that the final report will constitute the keystone of an effective, practical safety program for the community.

Since inauguration of this project, established construction and industrial safety methods and principles have been utilized to facilitate completion of all work at the earliest possible date. Now it will be possible to cover the public aspects of safety more completely.

I trust we may count on such additional assistance of staff experts from the Council as may be necessary, and we will in due time inform you of our needs.

The National Safety Council has rendered a real public service by assisting us on this project.

Very truly yours,

/s/K. D. Nichols.
K. D. NICHOLS,
Colonel, Corps of Engineers,
District Engineer.



C O P Y



**ARMY SERVICE FORCES
UNITED STATES ENGINEER OFFICE
MANHATTAN DISTRICT
OAK RIDGE, TENNESSEE**

IN REPLY
REFER TO **EIDMC-42**

12 January 1944.

Subject: Recommendations in National Safety Council Survey.

MEMORANDUM to The District Engineer, Manhattan District, Oak Ridge, Tennessee.

1. Four months have elapsed since the National Safety Council undertook its survey of Oak Ridge, and two months have passed since the Council's detailed report was received.

2. Of the 69 specific recommendations in the report, 32 have been adopted and put into effect, and an additional 21 recommendations are in the process of adoption. Thus, over three-fourths of the recommendations have already had favorable action.

3. Twenty of the 25 traffic safety ideas have been adopted. In addition to the items covered in the report, two Driver Permit Bureaus based on scientific testing procedures have been placed in operation, and selected traffic patrolmen have received 15 hours of special training in accident investigation and traffic patrol, and additional guard training is planned.

4. The proportions of recommendations which have been or are being acted on in other fields are:

- a. Eleven of 19 home safety items.
- b. All 13 school safety items.
- c. Nine of 11 accident record items.

5. The community safety council recommendations have not been adopted. An Oak Ridge Community Safety Committee appointed by the District Engineer seemed to more nearly fit the needs of the community, and formation of such a committee has been proposed to the District Engineer.

**JAMES R. MADDY,
District Safety Engineer.**

~~CONFIDENTIAL~~



DEC 9 AM

NATIONAL SAFETY COUNCIL

INCORPORATED
20 NORTH WACKER DRIVE
CHICAGO 6, ILLINOIS

RECEIVED
B u
D
1944

2:02

19

Col. K. D. Nichols
District Engineer
U. S. Engineer Office
Clinton Engineer Works
Box E
Oak Ridge, Tenn.

November
30
1944

Dear Colonel:

I am enclosing herewith our Second Progress and Supplementary Report to the Consolidated Report on a Community Safety Program for the Clinton Engineer Works.

The report indicates that the safety program on the project has continued to accomplish gratifying results.

It is sincerely hoped that the staff of the National Safety Council may continue to be of service to the U. S. Engineers.

Eight of the ten typewritten copies are enclosed herewith; two copies will be kept at our office, and you may be assured that the contents will be kept in strict confidence.

Sincerely yours,

Ned H. Dearborn
President

NHD/cw
enc. 8

Classification ~~confidential~~ changed to *Conf.*

By authority of D. M. B. E. D. By *W. J. Johnson*

~~CONFIDENTIAL~~

~~CONFIDENTIAL~~

File 1 of 1
TC 12/2

NATIONAL SAFETY COUNCIL
INCORPORATED

20 NORTH WACKER DRIVE
CHICAGO 6, ILLINOIS

COLONEL JOHN STILLWELL, PRESIDENT
NED H. DEARBORN, EXECUTIVE VICE-PRESIDENT

VICE-PRESIDENTS
FRANK AND FLORENCE
I. W. MILARD
JOHN AND FANNIE
H. E. MINER
WALTER S. PAPER
LOCAL SAFETY ORGANIZATIONS
JUDGE LEE SKEEL
MEMBERSHIP
R. T. SOLENTIN
SCHOOLS AND COLLEGES
DR. H. T. HEALD
L. J. SOREINSON
TRANSPORTATION
LEWIS PALMER

BOARD OF TRUSTEES
WILLIAM A. IRVIN, CHAIRMAN
WINTHROP W. ADAMS
SEWELL L. ASER
MORGAN H. BRANNARD
WILLIAM G. CHANDLER
HOWARD C. CONLEY
BENJAMIN F. FARLESS
WALTER S. GIFFORD
E. ROLAND HARRISMAN
THOMAS L. HARRISON
ROBERT C. STANLEY
COLONEL JOHN STILLWELL
THOMAS J. WATSON
CHARLES E. WILSON

man. 7-29-31 general

11/11/43 129.31

Col. K. D. Nichols
District Engineer
Manhattan Engineer District
Oak Ridge, Tenn.

November
12
1943

Dear Colonel:

I have the pleasure of submitting herewith our consolidated report, "A Community Safety Program", based on data gathered and analyzed by staff members of the National Safety Council.

Field surveys were made in August and September, 1943, by three staff members who visited the Clinton Engineer Works. Later, the information that they obtained was studied at the offices of the Council and recommendations and supporting discussions which are presented here were prepared.

Preliminary reports were submitted to the Area Engineer at the time staff members were in Oak Ridge pending the consolidated report.

The Corps of Engineers is to be congratulated on the prompt action on some of the findings of this survey. It is gratifying to know that there is such a keen interest in saving manpower for warpower through the promotion of a complete safety program.

Ten copies of this report were typed, eight of which are submitted herewith, while two copies will be kept at the offices of the Council. You have my assurance that the contents of the report will be kept in strictest confidence.

Sincerely yours,

John Stillwell

Colonel John Stillwell
President

JS/cw
Encl.

~~CONFIDENTIAL~~

C13



C O P Y

ARMY SERVICE FORCES
UNITED STATES ENGINEER OFFICE
MANHATTAN DISTRICT
OAK RIDGE, TENNESSEE

IN REPLY
REFER TO EIDMS
729.3

11 December 1944

Mr. Ned H. Dearborn, President,
National Safety Council,
20 North Wacker Drive,
Chicago 6, Illinois.

Dear Mr. Dearborn:

I am grateful for the Second Progress Reports on the community safety programs at Clinton Engineer Works and Hanford Engineer Works.

As you know, most of the recommendations made by National Safety Council experts have been adopted and have been instrumental in improving living conditions and personal security on these projects. The advice of your men has proven sound and practical.

The assistance given by your organization has been a major factor in our successful program to reduce accidental injuries to workers and their families, and has, consequently, been an important contribution to the war effort.

Public recognition for this work cannot be given at this time, but is certainly deserved and will be forth-coming when security regulations can be relaxed.

Yours sincerely,

K. D. NICHOLS,
Colonel, Corps of Engineers,
District Engineer.

16 March 1945

MINUTES OF COMBINED SAFETY MEETING

Meeting called to order at 9:05 A. M., Mr. M. E. Ridge presiding.

Those in attendance at the meeting were:

L. L. Kelly	U.S.E.D.	J. G. Aldrich	U.S.E.D.
E. L. Brawley	U.S.E.D.	W. J. Enders	R-A
Sgt. J. Hammoch	U.S.E.D.	E. J. Reeder	U.S.E.D.
L. G. Bamer	C & CCC	J. W. Smouse	A. I. T.
J. W. Hensley	S & W	G. J. Fisher	U.S.E.D.
J. C. Watkins	U.S.E.D.	C. M. Cummins	U.S.E.D.
C. B. Spies	U.S.E.D.	C. J. Phillips	U.S.E.D.
Albert Stanford	S & W	M. E. Ridge	U.S.E.D.
W. S. Rasmussen	U.S.E.D.	Lee Bagwell	T. E. C.
Sgt. H. T. Markee	U.S.E.D.		

Mr. Ridge opened the meeting by giving a resume of the "Color Dynamics" meeting of March 13, sponsored by the Pittsburgh Plate Glass Company. He stated that four films on this subject were to be loaned this office. These will arrive in this order: first one this week, second one on 3 April, third one on 1 May, and the fourth at a later date. All contractors' representatives will have an opportunity to view these films.

Mr. Bamer spoke on the committee meeting of the proposed Safety Club. Application forms with copies of the by-laws will be sent out this week to safety representatives. The official name of the club will be "Oak Ridge Safety Engineers Club." It is proposed to have a representative of every contractor on the committee. The committee will pass on the status of each application for membership. Full memberships, associate memberships and allied memberships will be set up. The primary purpose of the club is to have an organization for safety engineers in Oak Ridge. The secondary purpose would be to have membership in ASSE. There was some doubt as to whether or not the club could be taken in as a chapter of the ASSE. It is proposed to limit membership to safety personnel. The committee will meet again in the near future to pass on membership. Then the first full meeting will pass on by-laws, fees, etc.

Mr. Rasmussen spoke on the exchange of house organs that was set forth in the last combined meeting on 1 March. He distributed a list of all contractors who have house organs.

Mr. Rasmussen further spoke on the rules governing methods of changing heavy duty tires to prevent lock rims from springing out. He passed out sketches of a tire inflation safety rack for use on this.

Mr. Ridge stated there would be an extensive paving program for Clinton Engineer Works this summer. The type of surface will depend on the traffic volume. Center lining and lane lining of new roads which will take the paint will be instigated as soon as construction permits. Beaded center lines will be installed on main roads with heavy traffic.

Mr. Ridge also advised that uato licenses were being sold on the area and suggested this information be used in contractors house organs.

Mr. Ridge stated more sprinkling is being done on roads with heavy dust.

Mr. Fisher advised that seven traffic signals had been approved for installation.

Mr. Fisher requested more complete information on the vehicle accident forms. He stated that the collision diagrams were not being completed. Reports should also indicate the responsibility for the accident.

Mr. Ridge advised that emergency lighting for exits in all theaters and hospitals had been ordered. Also that a survey of exits in public buildings had been completed and recommendations for correction had been made.

Mr. Kelly requested that contractors' employees who had Red Cross First Aid Instructors Certificates register with Mrs. Hutchins of the Red Cross. This will enable expediency of some Red Cross first-aid courses now contemplated.

Mr. Smouse raised the question of the necessity of all emergency vehicles traveling at great rates of speed with sirens open. Mr. Ridge advised this matter was being looked into.

Meeting adjourned at 10:15 A. M.

L. L. Kelly
Community Safety Engineer

MINUTES OF COMBINED SAFETY MEETING

29 March 1945

Meeting was called to order at 9:00 A. M., Mr. M. E. Ridge presiding.

Those in attendance at the meeting were:

D. N. Kelly	J. A. Jones	J. C. Watkins	U.S.E.D.
A. W. Meyers	Aetna	J. W. Hensley	S. & W.
E. L. Brawley	U.S.E.D.	C. B. Spies	U.S.E.D.
Sgt. H. Markee	U.S.E.D.	Earl Reeder	U.S.E.D.
M. E. Ridge	U.S.E.D.	G. R. Paravis	U.S.E.D.
St. Clair Smith	F.B.&D.	James R. Maddy	U.S.E.D.
J. Hannoeh	U.S.E.D.	Albert Stanford	S.&W.
J. E. Martin	C.C.C.C.	C. J. Phillips	U.S.E.D.
C. M. Cummins	U.S.E.D.	J. G. Aldrich	U.S.E.D.
Lee Bagwell	T. E. C.	William J. Enders	R-A
L. L. Kelly	U.S.E.D.	R. T. Bartnett	R-A
J. W. Smouse	A. I. T.	W. W. Rasmusse	U.S.E.D.
		W. Popejoy	C. L.

Mr. Ridge opened the meeting by reminding the group that the next scheduled combined meeting would be held 12 April. A color expert will give a talk on color engineering at that time.

Mention was made of the plan to paint cross-lines and other markings on our streets and highways in the near future. The safety engineers were asked to send any suggestions to the Public Safety Section of the U.S.E.D. Safety Branch.

Mr. Ridge stated that there was still some confusion on the reporting of traffic accidents. Some are not reported through the right channels while many are not reported at all.

A discussion was started on what to do about drivers who have three or more known accidents chalked up against their record and still continue to drive a Government vehicle. It was suggested that the Review Board take action on such cases that come to their attention. It was felt by those present that definite action should be taken by the individual contractor in barring men from driving if they had three or more accidents for which they were responsible. The safety directors were urged to present this problem to their various managements for enforcement. It was also decided that the U.S.E.D. Safety Branch would notify the contractor's safety department whenever two chargeable accidents were chalked up against an employee.

Mr. Aldrich suggested that the driver permit be picked up on termination. After an inquiry into the U.S.E.D. Safety Branch record file for previous accidents, the permit could be re-issued.

Mr. Kelly asked for a record of the Review Board weekly citation. He was informed that these weekly citations are supposed to be sent to all

the safety departments. To avoid confusion it was decided that the U.S.E.D. Liaison Safety Engineers make this information available to the various contractors' safety departments. Mr. Ridge reminded the group that it had previously been decided that upon change from one contractor to another the employee's permit could be changed by the hiring contractor or the employee could be sent to the Permit Bureau for a re-issuance.

With reference to driver training activities, it was disclosed that Roane-Anderson has recently set up a school of this sort. As it is impractical for each small contractor to have a complete set-up for training, it was suggested that large organizations which have, or intend to have, a driver training program make some arrangements to assimilate a few driver trainees from other small organizations, and in that way promote driver training throughout the area.

Mr. Rasmussen stated that applications for the Safety Engineers' Club have just been sent out and should be returned by the end of the week.

The question was brought up on whether adequate information was being obtained on serious cases sent to the Oak Ridge Hospital. This information was obtained by calling the U.S.E.D. Safety Office, but it was decided that henceforth the liaison safety engineers would give the information to the contractor's safety departments.

The safety directors were again urged to use their house organs in promoting their public safety program.

Mr. Smouse brought up the problem of what to do about the crowded bus condition. He felt that a public educational program sponsored by the contractors to make the people realize that it was a definite hazard to crowd into the busses would remedy the condition.

Mr. Popejoy thought that the contractors could use interesting items for the house organs, particularly on public safety. These items would be accumulated by the U.S.E.D. Safety Office and sent to the various contractors. Meeting adjourned at 10:15 A. M.

G. R. PARAVIS

Appendix C-15

Brief histories of two men on the Government safety staff are presented to indicate the calibre of personnel recruited by the District.

James E. Maddy, District Safety Engineer

Education: Mr. Maddy attended Phillips University, Enid, Oklahoma and Oklahoma A. & M. College, Stillwater, Oklahoma, majoring in Civil Engineering.

Previous Experience: From 1928 to 1934 Mr. Maddy was on the staff of the U. S. Geological Survey and the U. S. Coast and Geodetic Survey on horizontal and vertical control surveys and 1st and 2nd order triangulation work. In the latter position he served as Supervising Engineer, in charge of local control surveys for the state of Oklahoma. In 1934 Mr. Maddy joined the U. S. Forest Service where he served as Regional Safety Engineer (14 north atlantic states) until the spring of 1941 when he was transferred to the Quartermaster Corps in Baltimore, Maryland as Third Zone Safety Engineer. Subsequently he served with the Corps of Engineers as District Safety Engineer, Baltimore District and Division Safety Engineer, Middle Atlantic Division, as well as the first Director of Safety for the newly-formed Military District of Washington. In these positions Mr. Maddy was responsible for directing the construction safety activities at such installations as Radford Ordnance Works, Newport News Staging Area, Camp Pickett, Ft. Meade, Aberdeen Proving Ground, Edgewood Arsenal, Ft. Belvoir, Indiantown Gap Military Reservation and more than a score of other projects of widely varied nature throughout Pennsylvania, Maryland, Virginia and the District of Columbia. The construction safety program which Mr. Maddy supervised had a peak coverage of 67,000 employees. During the 27 months in which Mr. Maddy directed this large construction program, the injury frequency rate was reduced from 33 to 11 disabling injuries per million employee-hours.

Manhattan District Service: In 1943 Mr. Maddy was transferred to the Manhattan Engineer District and charged with the responsibility of setting up and organizing a complete and comprehensive safety program for all activities of the new and vast undertaking. His instructions were to consider not only industrial and construction safety problems, but also be ready with an operating plan for community and other public safety programs for the communities to be built in connection with the District Work.

2d Lt. W. G. Johnson, Assistant District Safety Engineer

Education: Lt. Johnson attended the Central Y.M.C.A. College in Chicago, having received a scholarship to that institution as the result of high school academic honors. Lt. Johnson ranked first in his class when receiving an A.B. degree in business administration in 1935. He immediately entered upon graduate studies at the University of Chicago, specializing in mathematics and statistics.

Previous Experience: In 1936 and 1937 Lt. Johnson was a statistician and investigator in various branches of the Government service. In 1937 he joined the statistical staff of the National Safety Council and worked principally

in the field of traffic accident investigation and reporting in a program of advice and assistance to city and state governments. In 1940 Lt. Johnson was made Chief Statistician of the National Safety Council. During the next 3 years he was active in developing methods of using accident records -- industrial, traffic, school, home and farm -- to direct prevention work at the immediate and real causes of the accidents. In the early part of 1943, Lt. Johnson was given the responsibility of directing the Program Department of the Council, which consisted of the Industrial, Traffic, Home, School, Farm, and Statistical Divisions -- all of the technical work of the national organization.

Army Service: Lt. Johnson was inducted in September 1943. Upon completion of basic training he was transferred to the Manhattan District where he served as Assistant District Safety Engineer until February 1944. At the request of the Provost Marshal General, Lt. Johnson (then a Sgt.) was released to participate in the early studies of ways and means of preventing accidental injuries to military personnel. In July 1944, Lt. Johnson entered the Engineer Officer Candidate School, Fort Belvoir, and in November was commissioned. He was re-assigned to the Manhattan District, where he resumed his duties as Assistant District Safety Engineer. Lt. Johnson's services have been particularly valuable because he has had varied safety experience in the many fields of accident prevention which confronted the District -- many aspects of industrial safety, traffic, home safety, school safety and others.

Appendix C-16

The following safety engineers served on the Government Safety staff, in addition to the key personnel listed in Paragraph 6-4. If an engineer was not in the District 30 June 1945, or if he served in two places, the former station is shown in parentheses.

<u>Resident Safety Engineers</u>	<u>Area</u>
Capt. E. F. Burdin ✓	(Beverly & Boston)
Capt. K. M. Farr ✓	(Chicago)
2nd Lt. G. R. Galloway	Y-12, CEW
Sgt. R. V. Batie ✓	Colorado
Sgt. Julius Hannooh ✓	K-25 Operations, CEW
Sgt. H. T. Markee ✓	X-10 and S-50, CEW
Mr. E. L. Brawley ✓	K-25 Construction, CEW
Mr. T. W. Dwyer ✓	Decatur (HEW).
Mr. V. R. Holmquist	HEW
Mr. R. C. LaPointe ✓	(New York)
Mr. G. R. Olsen ✓	(Decatur)
Mr. W. K. Shearer ✓	Tonawanda
Mr. R. A. N. Turner ✓	Wilmington
Mr. P. C. Wagner ✓	(Columbia)
Mr. C. O. Watkins ✓	Detroit
Mr. A. M. Wellands ✓	HEW

<u>Other Safety Engineers</u>	<u>Station</u>
1st Lt. M. V. Greer ✓	CEW
Sgt. D. F. Abernethy ✓	(CEW)
Sgt. H. Gilbert ✓	(District)
Sgt. F. J. McHale ✓	(HEW)
Corp. L. Moon ✓	(HEW)
Mr. J. G. Aldrich	CEW
Mr. J. M. Austin ✓	HEW (CEW)
Mr. L. G. Barnett ✓	CEW
Mr. L. A. Bowman ✓	CEW
Mr. Aymar Cater ✓	(CEW)
Mr. C. M. Cummins ✓	CEW
Mr. J. E. Dullea ✓	(Chicago)
Mr. G. J. Fisher ✓	CEW
Mr. J. C. Green ✓	Detroit
Mr. C. A. Goodell ✓	(CEW)
Mr. H. T. Harlee ✓	(HEW)
Mr. G. F. Hoge ✓	(CEW)
Mr. H. J. Hoose ✓	HEW (CEW)
Mr. L. L. Kelly ✓	CEW
Mr. E. R. Kontner ✓	(CEW)

Other Safety Engineers

Station

Mr. George Paravis ✓	(CEW)
Mr. C. J. Phillips ✓	District
Mr. K. I. Schreck ✓	(HEW)
Mr. Vavon Sherrill ✓	HEW
Mr. C. B. Spies ✓	CEW
Mr. J. H. Stark ✓	District
Mr. S. W. Stetler ✓	(CEW)
Mr. B. D. Varnado ✓	CEW (HEW)
Mr. R. R. Wilson ✓	(CEW)
Mr. J. C. Watkins ✓	CEW

MANHATTAN DISTRICT HISTORY

SAFETY PROGRAM

APPENDIX "D"

FORMS

<u>No.</u>	<u>Description</u>
1	Sample Occupational Injury Report (W.D., AGO Form No. 501) and Summary Report (W.D., AGO Form No. 502-1).
2	Sample Narrative Safety Inspection Report, (Form ED 404).
3	Sample Driver Record Card.
4	Sample Motor Vehicle Accident Investigation Report.

S A M P L E

DO NOT WRITE IN THIS SPACE				

WAR DEPARTMENT
INDIVIDUAL INJURY REPORT

REPORT No. 42	Do not write in this space
MONTH April 1945	

WHO, WHEN, WHERE	STATION Blank Area	DISTRICT Manhattan	DIVISION		
	LOCATION University of Blank	TYPE OF OPERATION Chemical Research		GOVERNMENT <input type="checkbox"/> CONTRACT <input checked="" type="checkbox"/>	
	NAME OF INJURED John Henry Doe		WHITE <input checked="" type="checkbox"/>	OTHER <input type="checkbox"/>	MALE <input checked="" type="checkbox"/>
			NEGRO <input type="checkbox"/>		FEMALE <input type="checkbox"/>
	OCCUPATION Toolmaker	TOTAL EXPERIENCE IN TRADE TO DATE (Yr.) 15	AGE 35	TIME OF INJURY: Date 4/6/45 Hour 9:08 (A.M. P.M.)	DATE STARTED LOSING TIME 4/7/45
	DEPARTMENT WHERE EMPLOYED OR EXACT LOCATION OF ACCIDENT Site X				DATE RETURNED TO WORK 4/19/45

NATURE AND SEVERITY OF INJURY	Describe in detail the nature of the injury and the part of the body affected Left index finger - nail partly torn off by injury - completely removed by surgery																						
	Attending Physician (Name) Dr. Walter H. Johnson - Site Z																						
	(Check X) Results of injury (Figures refer to American Standards Association Pamphlet Z16.1-1937): Nondisabling (2.7): First aid <input type="checkbox"/> Temporary partial disability (2.6) (3.6). <input type="checkbox"/>																						
	Disabling: <table border="1"> <thead> <tr> <th></th> <th>ACTUAL DAYS LOST</th> <th>TIME CHARGE</th> <th>(Days)</th> </tr> </thead> <tbody> <tr> <td><input checked="" type="checkbox"/> Temporary total disability (2.5) (3.5). Part of body affected <u>Left Index Finger</u></td> <td>12</td> <td>12</td> <td></td> </tr> <tr> <td><input type="checkbox"/> Permanent partial disability (2.4) (3.4). Part of body affected _____</td> <td></td> <td></td> <td>(Days)</td> </tr> <tr> <td><input type="checkbox"/> Permanent total disability (2.3) (3.3). Part of body affected _____</td> <td></td> <td></td> <td>(Days)</td> </tr> <tr> <td><input type="checkbox"/> Death (2.2), (3.2) Date of death _____</td> <td></td> <td></td> <td>(Days)</td> </tr> </tbody> </table>					ACTUAL DAYS LOST	TIME CHARGE	(Days)	<input checked="" type="checkbox"/> Temporary total disability (2.5) (3.5). Part of body affected <u>Left Index Finger</u>	12	12		<input type="checkbox"/> Permanent partial disability (2.4) (3.4). Part of body affected _____			(Days)	<input type="checkbox"/> Permanent total disability (2.3) (3.3). Part of body affected _____			(Days)	<input type="checkbox"/> Death (2.2), (3.2) Date of death _____		
	ACTUAL DAYS LOST	TIME CHARGE	(Days)																				
<input checked="" type="checkbox"/> Temporary total disability (2.5) (3.5). Part of body affected <u>Left Index Finger</u>	12	12																					
<input type="checkbox"/> Permanent partial disability (2.4) (3.4). Part of body affected _____			(Days)																				
<input type="checkbox"/> Permanent total disability (2.3) (3.3). Part of body affected _____			(Days)																				
<input type="checkbox"/> Death (2.2), (3.2) Date of death _____			(Days)																				

INVESTIGATOR'S STATEMENT	How did the accident which caused the injury occur, including what injured was actually doing? Cleaning magnesia plate of surface grinder, using squeegee, carriage was at extreme distance from grinding wheel but squeegee caught by wheel was thrown against injured's finger, tearing nail loose.	
	If cause is a violation of "Safety Requirements" state what section. What steps have been taken to prevent recurrence of such injuries? Grinding wheel not stopped while changing work and cleaning machine. Should have shut off.	

TYPE OF ACCIDENT *Part I (2.4) (4.4)	(Check X) Indicate the accident type:	
	<input type="checkbox"/> Striking against (contact with rough or sharp objects, resulting in cuts, etc., due to striking against, kneeling on, etc.). <input checked="" type="checkbox"/> Struck by (falling, flying, sliding, or moving objects). <input type="checkbox"/> Caught in, on, or between. <input type="checkbox"/> Fall on same level. <input type="checkbox"/> Fall to different level. <input type="checkbox"/> Slip and overexertion (not fall, resulting in strain, hernia, etc.).	<input type="checkbox"/> Contact with temperature extremes (resulting in burning, scalding, freezing, heat exhaustion). <input type="checkbox"/> Inhalation, absorption, ingestion (asphyxiation, poisoning, drowning, etc.). <input type="checkbox"/> Contact with electric current (resulting in electrocution, shock, etc.). <input type="checkbox"/> Accident type, not elsewhere classified.

AGENCY
*Part I (4.1), (4.2) Part II (1.3)

(Check X) What machine, tool, vehicle, object, substance, or exposure was closely connected with the injury? As far as practical select agency most subject to corrective action. Explain in a few words:

- | | |
|--|--|
| <input checked="" type="checkbox"/> Machines <u>Surface Grinder</u>
(Agitators, grinders, sewing machines, vises, saws, lathes, welding machines, etc.) | <input type="checkbox"/> Electrical apparatus
(Motors, transformers, lamps, appliances, etc.) |
| <input type="checkbox"/> Pumps and prime movers | <input type="checkbox"/> Hand tools
(Hand, mechanical, or electrical motive power; hammers, wrenches, sand blasters, welding tools) |
| <input type="checkbox"/> Elevators
(Freight or passenger) | <input type="checkbox"/> Chemicals
(Explosives, gases, vapors, acids, caustics, poisonous vegetation, etc.) |
| <input type="checkbox"/> Hoisting apparatus
(Cranes, shovels, dredges, etc.) | <input type="checkbox"/> Dusts
(Explosive, organic or inorganic; leather, emery, coal, etc.) |
| <input type="checkbox"/> Conveyors | <input type="checkbox"/> Radiations and radiating substances |
| <input type="checkbox"/> Boilers and pressure apparatus | <input type="checkbox"/> Working surfaces
(Floors, roofs, roads, stairs, platforms, etc.) |
| <input type="checkbox"/> Vehicles
(All types, land, sea, air) | <input type="checkbox"/> Miscellaneous agencies
(Any object or substance not classified above.) |
| <input type="checkbox"/> Animals
(Including insects and reptiles) | |
| <input type="checkbox"/> Mechanical power transmission apparatus | |

What part of selected agency was most closely involved? Grinding Wheel

UNSAFE CONDITION
*Part I (4.3)
Part II (2.2)

(Check X) Indicate which of the following unsafe mechanical or physical conditions of the selected agency led to the accident or was responsible for the accident.

- | | |
|---|--|
| <input type="checkbox"/> Improper guarding:
(Unguarded, inadequately guarded, etc.) | <input type="checkbox"/> Improper ventilation:
(Dusty, gassy, impure air source, etc.) |
| <input type="checkbox"/> Defective substances or equipment:
(Broken, rough, slippery, poorly designed, etc.) | <input type="checkbox"/> Improper dress or apparel:
(Lack of, unsuited or defective goggles, gloves, shoes, etc.) |
| <input type="checkbox"/> Hazardous arrangement:
(Unsafe piling, poor lay-out, etc.) | <input type="checkbox"/> Unsafe mechanical condition not elsewhere classified: |
| <input type="checkbox"/> Improper illumination:
(Insufficient light, glare, etc.) | <input checked="" type="checkbox"/> No unsafe mechanical condition. |

UNSAFE ACT
*FACTOR
Part II (4.2)

(Check X) Indicate what unsafe act on the part of injured person other person was involved. Select the violation of a commonly followed safe procedure which resulted in or was most closely associated with the accident.

- | | |
|---|---|
| <input type="checkbox"/> Operating without authority: | <input type="checkbox"/> Taking unsafe position or posture: |
| <input type="checkbox"/> Failure to secure or warn: | <input checked="" type="checkbox"/> Working on moving or dangerous equipment: |
| <input type="checkbox"/> Operating or working at unsafe speed: | <input type="checkbox"/> Distracting, teasing, startling: |
| <input type="checkbox"/> Making safety devices inoperative: | <input type="checkbox"/> Failure to use safe attire or personal protective devices: |
| <input type="checkbox"/> Using unsafe equipment: | <input type="checkbox"/> Unsafe act not elsewhere classified. |
| <input type="checkbox"/> Using hands instead of equipment, or equipment unsafely: | <input type="checkbox"/> No unsafe act. |
| <input type="checkbox"/> Unsafe loading, placing, mixing, combining: | |

UNSAFE PERSONAL FACTOR
Injured
Supervisor

(Check X) Indicate and describe the unsafe personal factors which permitted or occasioned the selected unsafe act.

- | | |
|--|---|
| <input checked="" type="checkbox"/> Improper attitude: <u>Carelessness</u>
(Disregard of instructions, violent temper, absentmindedness, nervousness, etc.) | <input type="checkbox"/> Lack of knowledge or skill:
(Unaware of safe practice, unpracticed, etc.) |
| <input type="checkbox"/> Bodily defects:
(Defective eyesight, hearing, fatigue, hernia, muscular weakness, etc.) | <input type="checkbox"/> Unsafe personal factor not elsewhere classified: |
| | <input type="checkbox"/> No unsafe personal factor. |

A Supervisor: was was not at the scene and directing operations.

- | | |
|--|--|
| <input type="checkbox"/> Assigned employee to improper job. | <input checked="" type="checkbox"/> Failed to inspect for hazards. |
| <input type="checkbox"/> Gave insufficient instructions or training. | <input type="checkbox"/> Failed to enforce safety regulations. |
| <input type="checkbox"/> Assumed improper attitude. | <input type="checkbox"/> Other (Specify) _____ |

* Figures refer to American Standards Association Pamphlet Z16.2-1941, Parts I and II.

Name of Firm University of Blank
Signature William Baker
Title SAFETY DIRECTOR

Kenneth R. Jones
Government Safety Engineer or Officer.

MONTH	YEAR	A	S	IND.	EST.

CONTROL APPROVAL
SYMBOL MGB-22

WAR DEPARTMENT

Monthly Injury Summary Report for April, 1945

1. NAME OF PLANT, POST, OR FACILITY DISTRICT DIVISION
 Blank Area Manhattan

2. LOCATION OF PLANT COVERED BY REPORT STREET CITY STATE
 P. O. Box 1011 Blank Illinois

3. PRINCIPAL PRODUCTS (If nonmanufacturing, state type of operation and materials handled)
 Confidential

EXPOSURE:	(A) MALE		(B) FEMALE		(C) TOTAL	
	Number (a)	Time Charges or Days Lost (b)	Number (c)	Time Charges or Days Lost (d)	Number (e)	Time Charges or Days Lost (f)
4. TOTAL EMPLOYEE HOURS WORKED					412,222	
5. FATALITIES					0	
6. PERMANENT TOTALS					0	
7. PERMANENT PARTIALS					0	
8. TEMPORARY TOTALS	1	12	1	3	2	15
9. TOTAL (5-6-7-8)	1	12	1	3	2	15

10. FREQUENCY RATE 4.85 $\left(\frac{\text{TOTAL DISABLING INJURIES (ITEM 9E) TIMES ONE MILLION}}{\text{TOTAL EMPLOYEE-HOURS WORKED (ITEM 4C)}} \right)$

11. SEVERITY RATE 0.04 $\left(\frac{\text{TOTAL DAYS CHARGED (ITEM 9E) TIMES ONE THOUSAND}}{\text{TOTAL EMPLOYEE-HOURS WORKED (ITEM 4C)}} \right)$

12. ACTUAL DAYS LOST (ALL DISABLING INJURIES):	MALE	FEMALE	TOTAL

MOTOR VEHICLE ACCIDENT SUMMARY

To include only vehicles owned or leased by the Government and operated by Government employees

Type	Number of vehicles (a)	Total miles (b)	Number of accidents (c)	Frequency rate* (d)	Amount of Property Damage	
					Government vehicle (e)	Other vehicle (f)
13. PASSENGER CARS	26	34,156	1	2.93	\$ 56.25	\$
14. TRUCKS	5	12,930	0	0	\$ 0	\$
15. TOTALS	31	47,086	1	2.12	\$ 56.25	\$

*Accidents per 100,000 miles.

ILLNESS	Number Cases (a)	Number Treatments (b)	Days Lost (c)	Deaths (d)	Predominant Nature of Illness (e)	Number Treatments for Accidents (f)
16. INDUSTRIAL						
17. NONINDUSTRIAL						

18. GOVERNMENT EMPLOYEES CONTRACTORS' EMPLOYEES

MILITARY CONSTRUCTION

AIR CORPS FACILITIES ORDNANCE PLANTS PORT FACILITIES

TROOP FACILITIES ORDNANCE STORAGE OTHER STORAGE

GENERAL HOSPITAL CHEMICAL PLANTS MISCELLANEOUS

RIVER AND HARBOR

DREDGING

LEVEES, JETTS, REVET.

LOCKS, DAMS

BOAT YARDS

FLOOD CONTROL

DREDGING

LEVEES, JETTS, REVET.

DAMS

DIST. OR DIVISION PERSONNEL

CIVIL WORKS

Occupation	Lost-Time Injuries			Days Lost This Month	Total Man-Hours	Occupation	Lost-Time Injuries			Days Lost This Month	Total Man-Hours
	Fatal	Lost Time	Total				Fatal	Lost Time	Total		
20. CARPENTERS	0	0	0	0	1,080	Janitors	0	0	0	0	1,908
21. ELECTRICIANS	0	0	0	0	170	Plant Operators	0	0	0	0	35,568
22. PLUMBERS						33. Electricians	0	0	0	0	1,080
22. STEAMFITTERS						34. Floor Layers	0	0	0	0	76,752
23. PAINTERS	0	0	0	0	144	35. Lab. Research	0	3	3	3	153,798
24. ROOFERS						36. Survey Crews					
25. SHEET METAL WORKERS						37. Lock Masters					
26. EQUIPMENT OPERATORS	0	0	0	0	200	38. Shop Assistants	0	12	12	12	61,568
27. VEHICLE OPERATORS	0	0	0	0	398	39. Guards	0	0	0	0	5,429
28. STEELWORKERS						40. Fireman	0	0	0	0	53,238
28. RIGGERS						41. Admin. Supervisory	0	0	0	0	9,885
29. MACHINISTS	0	0	0	0	1,119	42. Misc. (Specify)	0	0	0	0	9,885
30. WELDERS						43. All Others	0	0	0	0	9,885
31. MASON TRADES CONCRETE WORKERS						TOTAL	0	15	15	15	412,222

REPORT OF DAYS LOST THIS MONTH

Occupation (a)	Name (b)	Date			Days Lost		Remarks (h)
		Injured (c)	Started Losing Time (d)	Returned to Work (e)	This Month (f)	This Year (g)	
Toolmaker	John Henry Doe	4/6/45	4/7/45	4/19/45	12	0	Nail torn from finger.
Lab. Assistant	Mary Belle Poe	4/10/45	4/11/45	4/14/45	3	0	Mouse bite. (Effect of Antitetanus Serum)

Prepared by:

JOHN DOE, Captain, Corps of Engineers

SAFETY OFFICER

Signature

Title

NARRATIVE SAFETY INSPECTION REPORT

DISTRICT Manhattan	<input type="checkbox"/> GOVERNMENT EMPLOYEES	<input checked="" type="checkbox"/> CONTRACTORS' EMPLOYEES	
DIVISION	MILITARY CONSTRUCTION		RIVER & HARBOR
STATION Chicago Area	<input type="checkbox"/> AIR CORPS FACILITIES	<input type="checkbox"/> CHEMICAL PLANTS	<input type="checkbox"/> DREDGING
LOCATION Metallurgical Laboratory University of Chicago	<input type="checkbox"/> TROOP FACILITIES	<input type="checkbox"/> PORT FACILITIES	<input type="checkbox"/> LEVEES, JETTIES, REVETMENTS
	<input type="checkbox"/> GENERAL HOSPITAL	<input type="checkbox"/> OTHER STORAGE	<input type="checkbox"/> LOCKS & DAMS
	<input type="checkbox"/> ORDNANCE PLANTS	<input checked="" type="checkbox"/> MISCELLANEOUS	<input type="checkbox"/> BOAT YARDS & MARINE WAYS
	<input type="checkbox"/> ORD. STORAGE, ETC.		<input type="checkbox"/> DAMS
OPERATIONS	<input type="checkbox"/> POST ENGR. OPERATIONS	<input type="checkbox"/> DISTRICT OR DIVISION OFFICE PERSONNEL	<input type="checkbox"/> CIVIL WORKS (N.E.C.)

CODE NO.	REC. NO.	DESCRIPTION	DISPOSITION
8312.00	552	All acid and alkali solutions to be neutralized in laboratories before removal for transportation - New Chem. 3-5-45.	Adopted
8306.01-F	553	Immediate discontinuance of use of defective stepladder - Site B - Engineer's Room. 3-6-45.	Adopted
None	554	Remove crash box from gate on enclosure at west end of corridor - Ryerson Basement Corridor. 3-9-45.	Pending
8316.01-d	555	Cap all gas outlets except where used for laboratory or shop work - Ryerson Basement Rooms. 3-9-45.	Pending
8308.01-J	556	Rewire the new fixtures and convenience outlets at west end of corridor to put them on a power circuit separate from the EXIT lighting circuit. Replace red bulb in EXIT lighting fixture in corridor by entrance to Room 61. At present time a number of convenience outlets and lighting fixtures are connected to EXIT lighting fixture just outside Room 61 in Ryerson Basement Corridor. Also, convenience outlets have been connected to EXIT lighting fixture in Room 62. Remove this extra load on the special circuit as it is contrary to fire regulations and may result in overloading the circuit at a time when EXIT lighting is of vital importance - Ryerson Basement Corridor and Room 61. 3-9-45	Pending
8302.11-D	557	Remove to some out-of-the-way storage space the stone and slate slabs now stored under the steps in the east end of the Ryerson Basement Corridor. 3-9-45.	Pending

NARRATIVE SAFETY INSPECTION REPORT

DISTRICT	Manhattan	<input type="checkbox"/> GOVERNMENT EMPLOYEES	<input checked="" type="checkbox"/> CONTRACTORS' EMPLOYEES
DIVISION		<input type="checkbox"/> MILITARY CONSTRUCTION	<input type="checkbox"/> RIVER & HARBOR
STATION	Chicago Area	<input type="checkbox"/> FLOOD CONTROL	
LOCATION	Metallurgical Laboratory University of Chicago	<input type="checkbox"/> AIR CORPS FACILITIES	<input type="checkbox"/> CHEMICAL PLANTS
		<input type="checkbox"/> TROOP FACILITIES	<input type="checkbox"/> PORT FACILITIES
		<input type="checkbox"/> GENERAL HOSPITAL	<input type="checkbox"/> OTHER STORAGE
		<input type="checkbox"/> ORDNANCE PLANTS	<input type="checkbox"/> MISCELLANEOUS
		<input type="checkbox"/> ORD. STORAGE, ETC.	
	OPERATIONS	<input type="checkbox"/> POST ENGR. OPERATIONS	<input type="checkbox"/> DISTRICT OR DIVISION OFFICE PERSONNEL
			<input type="checkbox"/> CIVIL WORKS (N.E.C.)

CODE NO.	REC. NO.	DESCRIPTION	DISPOSITION
None	558	Rehang door to front entrance in accordance with drawings (to conform to fire regulations). Site B - Front Entrance. 3-9-45.	Adopted
None	559	Driving automatic lift truck up south Armory ramp - not to drive with a grade of over 7% - Armory. 3-15-45.	Adopted
None	560	Change safety shower valve in E corridor, New Chem, to provide opening of valve by pulling downward on valve handle in place of pushing upward.	Pending
None	561	Ledgers of three lumber racks to be suitably supported with vertical supports resting on sills on ground - Armory Arena. 3-20-45.	Pending
None	562	Knives to be sheathed when not in use - Armory. 3-20-45.	Pending
None	563	Floor to be properly filled in - Armory.	Pending
8318.06-1	564	Riders should not be carried on battery case of automatic truck - only driver should be permitted to ride automatic truck - Armory. 3-31-45.	Adopted
8316.01-3	565	Repair Armory Incinerator. 3-29-45.	Pending

Recommendations Made:	14
Recommendations Pending:	9
Recommendations Pending firm.	
Previous Reports:	28
Recommendations Made to Date:	565
No. of Employees:	1533

Notes

Rec. No. 455 of 1-31 Oct. 1944 reported adopted 3-1-45.
 Rec. No. 499 of 1-31 Dec. 1944 reported adopted 3-1-45.
 Rec. No. 527 of 1-28 Feb. 1945 reported adopted 3-6-45.
 Rec. No. 528 of 1-28 Feb. 1945 reported adopted 3-8-45.
 Rec. No. 543 of 1-28-Feb. 1945 reported adopted 3-5-45.
 Rec. No. 550 of 1-28 Feb. 1945 reported adopted 3-13-45.

/s/ PAUL BARANOWSKY
PAUL BARANOWSKY, Captain, C.E.

~~RESTRICTED~~
SAFETY ENGINEER

Indicates
revocation



Indicates two
accidents



DRIVER RECORD

SAMPLE

Name Clarence P. Doe Badge No. 14-742 Starting Date January 7, 1945
Address Paris, Tennessee Employer Ridge Const. Co. Position Chauffeur
Works Address 1. Motor Pool 2. 1020 Doolittle Street 3. _____
State Permit Tennessee Year 1943 Valid to 1945 Chauffeur's License: Yes _____ No. x
U. S. E. D. Permit No. 9489 Limitations None Vehicle Car
Glasses: For Driving No For Reading No Read English Yes Sex Male Age 42 Color W

EXAMINATIONS

Date	VISUAL				Inclosed Area	Road Test	Written	Reaction Time	Remarks
	Field	Glare	Acuity	Depth					
<u>1/8/45</u>	<u>C</u>	<u>D</u>	<u>C</u>			<u>C</u>	<u>A</u>		

Remarks: Permit revoked by Review Board 4/22/45. Reckless driving on Oak Ridge Turnpike on 4/21/45.

ENGINEER DEPARTMENT MOTOR VEHICLE ACCIDENT REPORT

(For USED Use)

REPORT OF Vehicle Accident Investigation Squad.

Accident Number 8472
Severity: P.D. P.I. Fatal

LOCATION OF ACCIDENT

Y Accident Occurred in Anytown State Tennessee.

RURAL _____ miles _____ of _____ in _____ State _____
Distance Direction City or town

ACCIDENT OCCURRED ON: Market Street
Give name or number of street or road

At intersection with Jackson Avenue.
Give name or number of street or road

OR

Not at intersection _____ Feet _____ of _____
Distance Direction Name (or otherwise identify) nearest intersecting street, house no., building, highway, curve, bridge, railroad crossing, driveway, culvert, or other identifying landmark. Show exact distance, using two directions and distances, if necessary.

INVOLVED

Government-Operated vehicle
 Govt.-Owned, Contr.-Operated
 Off-Area Bus Private Veh.
 Pedestrian

DISTRIBUTION

Claims Safety Guard
 Contr.
 I. R.

TIME OF ACCIDENT

Date August 28, 1945
Time _____ A.M. 4:15 P.M.

GOVERNMENT VEHICLE - NO. 1 1942 Chevrolet Sedan vehicle Identification 1A-000 Company Operating B.O.
Year Make Type

Going East on Market Street No. of Passengers 2 date of last Safety inspection 8-25-43
(North, E, W, S.) Street or road name or number, driveway, etc. (Ex. driver)

Parts of vehicle damaged Right front fender and door. \$ 25.00 Estimated Actual

Driver Richard R. Roe Badge Number A-001 Age 25 Sex M Race W

Driver's Address 415 Elm Street. Anytown, Tennessee.

Number of hours on duty preceding accident 6 Government Permit 52943 None Driving Experience 8 Experience this Type Vehicle 8 Occupation Chauffeur
Number Limitations Years Years

Car being driven on official duty? yes From Federal Bldg. To Johnson Bldg. Did accident occur enroute? yes

distance danger was first noticed 10 speed at that time 10 speed at moment of accident 10 distance traveled after impact 0 Posted speed 25 Maximum safe speed for prevailing conditions 25
Feet M. P. H. M. P. H. M. P. H. M. P. H. M. P. H. M. P. H.

If disabled, were flags or flares displayed _____ If at R.R. crossing, was vehicle stopped before entering _____ or was speed reduced _____ to _____ M.P.H. what lights were in use _____

PRIVATE VEHICLE - NO. 2 1942 Chevrolet Coach vehicle Registration 00-000 Tenn. 1945
Year Make Type Number State Year

Going North on Jackson Ave. No. of Passengers (excluding driver) 3

Parts of vehicle damaged Left front fender and headlight \$ 40.00 Estimated Actual

DRIVER John Doe Badge Number 41-826 A.R. Age 40 Sex M Race W

Driver's Address 907 Rhea Ave. Anytown, Tennessee.

Driver's license: state Tenn. number 5296843 A type: Restricted chauffer operator Occupation Iron Worker

Owner Driver Address _____

distance danger was first noticed 10 speed at that time 25 speed at moment of accident 10 distance traveled after impact 16 Posted speed 25 Maximum safe speed for prevailing conditions 25
Feet M. P. H. M. P. H. M. P. H. M. P. H. M. P. H. M. P. H.

Damage to property other than vehicles None \$ _____
Name object, show ownership, and state nature and amount

INJURED 1. Name Irene Doe Age 37 Address 907 Rhea Ave. Anytown, Tenn.

Injured Male Female Nature of injuries Laceration on forehead. Pedestrian driver Passenger Helper Location in vehicle seat Veh. No. 2

Given first aid by _____ Taken to City Hospital By John Doe

2. Name _____ Age _____ Address _____

Injured Male Female Nature of injuries _____ Pedestrian driver Passenger Helper Location in vehicle _____ Veh. No. _____

Given first aid by _____ Taken to _____ By _____

WITNESSES

Jessie Jones address 342 Washington Blvd. where was witness? Front seat No.2



John Brown 813 Elm Street Pedestrian. Cor. Market & Jackson

Bill C. Smith 1172 N. Saginaw Street. Rear seat Vehicle No.1

Show additional vehicles, injured persons, and witnesses in Remarks or use another form

Date of Accident 8-28-45 vehicle Identification: No. 1 1A-000 No. 2 TENN. 00-000 No. 3

INVESTIGATOR'S DIAGRAM

1. Use dash lines to draw heavy lines which will show outline of roadway at place of accident
2. If the place of accident cannot be diagrammed on the guide lines below, use a sheet of plain paper
3. Show where the vehicles were in the roadway when accident occurred and where they finally came to rest
4. Use a solid line to show path of vehicle before accident 
5. Use a broken line to show path of vehicle after impact 
6. Number each vehicle and show direction of travel by arrow 
7. Label the streets and objects such as stop signs
8. Indicate distance and direction to landmarks

POINT OF IMPACT (Check one for each vehicle involved)									
Vehicle	1	2	3	Vehicle	4	5	6	7	8
<input type="checkbox"/>	<input type="checkbox"/>	<input type="checkbox"/>	<input type="checkbox"/>	<input type="checkbox"/>	<input type="checkbox"/>	<input type="checkbox"/>	<input type="checkbox"/>	<input type="checkbox"/>	<input type="checkbox"/>
<input checked="" type="checkbox"/>	<input type="checkbox"/>	<input type="checkbox"/>	<input type="checkbox"/>	<input type="checkbox"/>	<input type="checkbox"/>	<input type="checkbox"/>	<input type="checkbox"/>	<input type="checkbox"/>	<input type="checkbox"/>
<input type="checkbox"/>	<input type="checkbox"/>	<input type="checkbox"/>	<input type="checkbox"/>	<input type="checkbox"/>	<input type="checkbox"/>	<input type="checkbox"/>	<input type="checkbox"/>	<input type="checkbox"/>	<input type="checkbox"/>
<input type="checkbox"/>	<input type="checkbox"/>	<input type="checkbox"/>	<input type="checkbox"/>	<input type="checkbox"/>	<input type="checkbox"/>	<input type="checkbox"/>	<input type="checkbox"/>	<input type="checkbox"/>	<input type="checkbox"/>

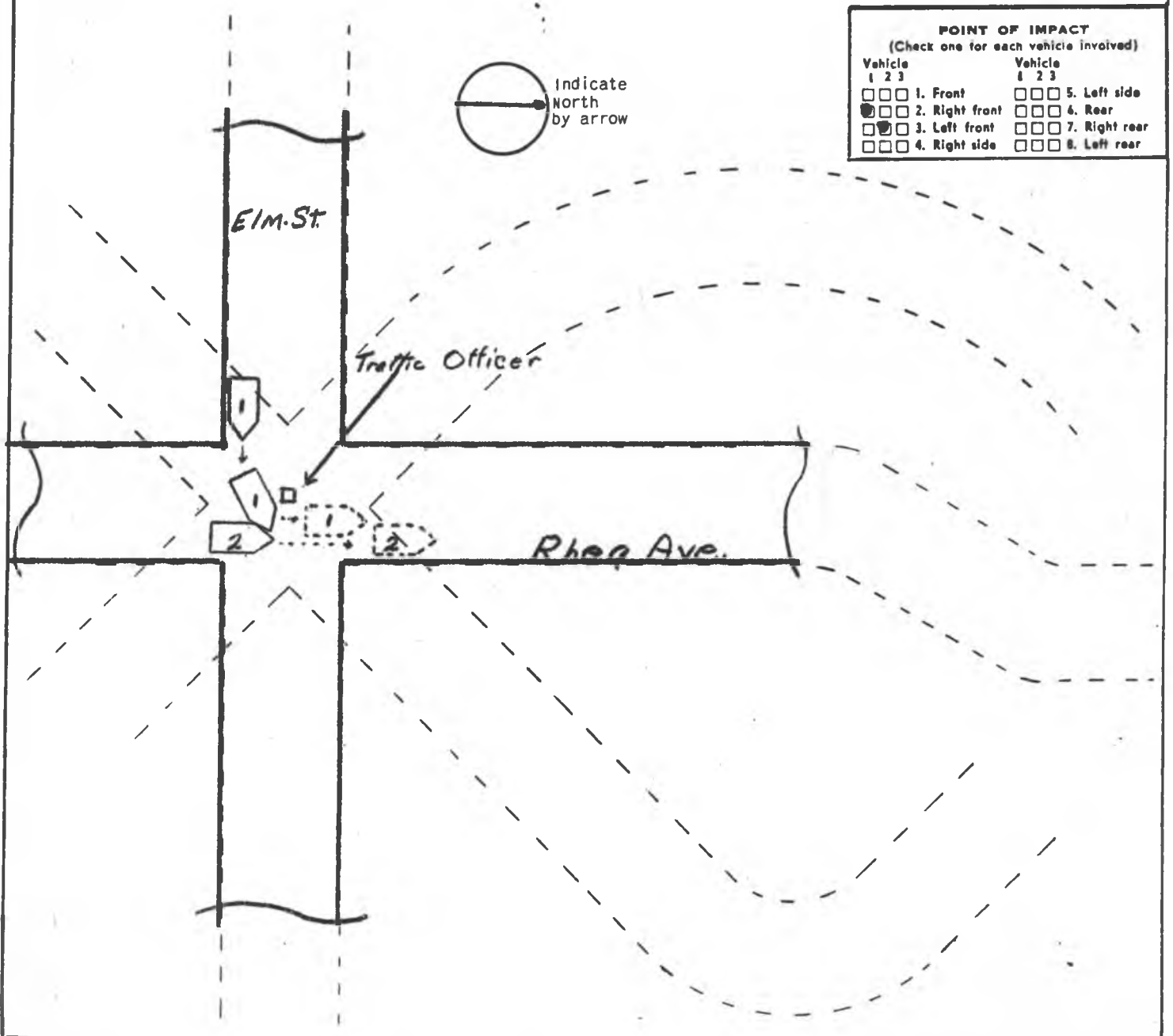

PEDESTRIAN: Was going ON Across _____ Street name, Highway No. From _____ To _____ (S.E. corner, or west side to N.E. corner, or east side, etc.)

Accompanied by _____ Just before accident pedestrian was: Walking Stumbling Running Fallen

	Vehicle			WHAT DRIVERS WERE DOING			Vehicle			VIOLATIONS INDICATED (check 1 or more for each vehicle)		
	1	2	3	1	2	3	1	2	3	1	2	3
<input type="checkbox"/> 1. Crossing at intersection:												
<input type="checkbox"/> a. With signal				1. Going straight ahead						1. Exceeding posted speed		
<input type="checkbox"/> b. Against signal				2. Making right turn						2. Exceeding safe speed		
<input type="checkbox"/> c. No signal				3. Making left turn						3. Did not have right away		
<input type="checkbox"/> d. Diagonally				4. Making U turn						4. On wrong side of road		
<input type="checkbox"/> 2. Crossing between intersections				5. Slowing down, stopping						5. Passing on hill		
<input type="checkbox"/> 3. From behind parked cars				6. Overtaking						6. Passing on curve		
<input type="checkbox"/> 4. Getting on or off vehicle				7. Forward from parking space						7. Cutting in		
<input type="checkbox"/> 5. Playing in roadway.				8. Backward from parking space						8. Following too closely		
<input type="checkbox"/> 6. Working roadway				9. Other backing						9. Failure to signal		
7. Walking in roadway (check two)				10. Stopped in traffic lane						10. Wide right turn		
<input type="checkbox"/> a. with traffic				11. Parked						11. Cut corner on left turn		
<input type="checkbox"/> b. Against traffic				(Check if applicable)						12. Turned from wrong lane		
<input type="checkbox"/> c. Sidewalks available				1. Skidding						13. Disregarded STOP sign		
<input type="checkbox"/> d. No sidewalks available				2. Avoiding vehicle, object or pedestrian						14. Disregarded WARNING sign		
<input type="checkbox"/> 8. Hitching on vehicle				3. Warning—horn, signal						15. Disregarded Stop-and-Go light		
<input type="checkbox"/> 9. Lying in roadway										16. Disregarded officer		
<input type="checkbox"/> 10. Not in roadway (explain)										17. Improper starting from parked pos.		
										18. Improper parking		
										19. Other improper action (explain)		
										20. No improper driving		
										Explain other violations:		

1	2	3	Ped.	CONDITION OF DRIVER AND PEDESTRIAN (check one or more)	Explain condition:
<input type="checkbox"/>	<input type="checkbox"/>	<input type="checkbox"/>	<input type="checkbox"/>	1. Had been drinking	_____
<input type="checkbox"/>	<input type="checkbox"/>	<input type="checkbox"/>	<input type="checkbox"/>	a. Obviously drunk	_____
<input type="checkbox"/>	<input type="checkbox"/>	<input type="checkbox"/>	<input type="checkbox"/>	b. Ability impaired	_____
<input type="checkbox"/>	<input type="checkbox"/>	<input type="checkbox"/>	<input type="checkbox"/>	c. Ability not impaired	_____
<input type="checkbox"/>	<input type="checkbox"/>	<input type="checkbox"/>	<input type="checkbox"/>	d. Not known whether impaired.	_____
<input type="checkbox"/>	<input type="checkbox"/>	<input type="checkbox"/>	<input type="checkbox"/>	2. Physical defect	_____
<input type="checkbox"/>	<input type="checkbox"/>	<input type="checkbox"/>	<input type="checkbox"/>	3. Sleepy, fatigued	_____
<input type="checkbox"/>	<input type="checkbox"/>	<input type="checkbox"/>	<input type="checkbox"/>	4. Apparently asleep	_____
<input type="checkbox"/>	<input type="checkbox"/>	<input type="checkbox"/>	<input type="checkbox"/>	5. Apparently normal	_____

Vehicle	CONDITION OF VEHICLE		
1	2	3	(Check one or more)
<input type="checkbox"/>	<input type="checkbox"/>	<input type="checkbox"/>	1. Defective brakes
<input type="checkbox"/>	<input type="checkbox"/>	<input type="checkbox"/>	2. One headlight out
<input type="checkbox"/>	<input type="checkbox"/>	<input type="checkbox"/>	3. Both headlights out
<input type="checkbox"/>	<input type="checkbox"/>	<input type="checkbox"/>	4. Tail light out or obscured
<input type="checkbox"/>	<input type="checkbox"/>	<input type="checkbox"/>	5. Parking lights only
<input type="checkbox"/>	<input type="checkbox"/>	<input type="checkbox"/>	6. Signal lights defective
<input type="checkbox"/>	<input type="checkbox"/>	<input type="checkbox"/>	7. Other lights or reflectors deficient
<input type="checkbox"/>	<input type="checkbox"/>	<input type="checkbox"/>	8. Defective steering gear
<input type="checkbox"/>	<input type="checkbox"/>	<input type="checkbox"/>	9. _____
<input type="checkbox"/>	<input type="checkbox"/>	<input type="checkbox"/>	10. No defects

Functioning	TRAFFIC CONTROL	WEATHER	LIGHT	Vehicle	VISION OBSCURED BY
<input type="checkbox"/>	1. Officer or watchman	1. Clear	1. Daylight	1	1. Rain, snow on windshield
<input type="checkbox"/>	2. Stop-and-go light	2. Cloudy	2. Dusk	2	2. Dirty windshield, windows
<input type="checkbox"/>	3. Stop sign	3. Raining	3. Dawn	3	3. Trees, crops, embankment
<input type="checkbox"/>	4. Warning sign	4. Snowing	Darkness with:	4	4. Building
<input type="checkbox"/>	5. _____	5. Fog	4. Street lights	5	5. Signboards
<input type="checkbox"/>	6. No control	6. _____	5. No street lights	6	6. Parked cars

KIND OF LOCALITY	ROADWAY CHARACTER	ROAD SURFACE	ROAD CONDITIONS
<input type="checkbox"/> 1. Construction, Industrial	<input type="checkbox"/> 1. straight road	<input type="checkbox"/> 1. concrete	<input type="checkbox"/> 1. Dry
<input type="checkbox"/> 2. Shopping and Business	<input type="checkbox"/> 2. Sharp curve or turn	<input type="checkbox"/> 2. Asphalt	<input type="checkbox"/> 2. Wet
<input type="checkbox"/> 3. Residential	<input type="checkbox"/> 3. Other curves	<input type="checkbox"/> 3. Gravel) oiled	<input type="checkbox"/> 3. Muddy
<input type="checkbox"/> 4. School and playground	<input type="checkbox"/> 1. Level road	<input type="checkbox"/> 4. Sand)	<input type="checkbox"/> 4. Snowy
<input type="checkbox"/> 5. Open country	<input type="checkbox"/> 2. Upgrade, vehicle 1	<input type="checkbox"/> 5. dirt) unoiled	<input type="checkbox"/> 5. Icy
<input type="checkbox"/> 6. _____	<input type="checkbox"/> 3. Hill crest	<input type="checkbox"/> 6. _____	(check one or more)
	<input type="checkbox"/> 4. downgrade, vehicle 1		<input type="checkbox"/> 1. Loose material on surface
			<input type="checkbox"/> 2. Holes, deep ruts
			<input type="checkbox"/> 3. Defective shoulders
			<input type="checkbox"/> 4. Other defects
			<input type="checkbox"/> 5. No defects

ROAD WIDTH AND LANES	
1. What was roadway width (Surface for vehicle travel)?	40 ft.
2. Total number of lanes? 4	were lanes marked? No
3. Were opposing lanes divided? No	If so, by what? _____
was road under construction or repair? <input type="checkbox"/> Yes <input checked="" type="checkbox"/> No	
Traffic: <input type="checkbox"/> Heavy <input checked="" type="checkbox"/> Average <input type="checkbox"/> Light	

DESCRIBE WHAT HAPPENED
Refer to vehicles by number. Also use this space for data on third vehicle, additional witnesses or injured persons and explanation of questions not fully answered by checking in boxes provided.

If more space is needed, use a sheet of plain paper of the same size.

Traffic officer at intersection gave vehicle No.1 signal to proceed through intersection. Vehicle No.2 disregarded stop signal and entered intersection. Vehicle No.2 crashed with right front side of vehicle No.1

ARRESTS & CITATIONS	John Doe Name	Reckless Driving Charge	City Police Court Court or Police Dept.
SIGNATURE	Sam P. Smith	Title or Badge No. Lieut. # 1602	Date 8-29-45

MANHATTAN DISTRICT HISTORY

SAFETY PROGRAM

APPENDIX "E"

PHOTOGRAPHS

<u>No.</u>	<u>Description</u>
1	Universal Safety emblem on gatehouse, Administration Building, Clinton Engineer Works.
2	Moane-Anderson driver training car.
3	Field of vision test of prospective driver.
4	Tractor-trailer bus driver taking inclosed area test.
5	School poster contest, Clinton Engineer Works.
6	Model Safety Home, Clinton Engineer Works.
7	Exhibits at the Clinton Engineer Works Safety Show.
8	Exhibits at the Hanford Engineer Works Safety Show.
9	Child Activities Show, Clinton Engineer Works.

APPENDIX E-1

The big Universal safety emblem on the Gatehouse, Administration Building, Clinton Engineer Works, was a daily safety reminder.



AG

APPENDIX E-2

The Roane-Anderson driver training car starts through an "inclosed area" test. The driver must negotiate the course without hitting a stanchion.



APPENDIX E-3

A check of the field of vision of prospective drivers is one of a number of physical checks made to determine whether a driver is physically capable of being a safe driver and to inform the driver of any minor deficiencies which he can compensate for in driving. The device illustrated will screen out a driver who is unable to see cross-traffic or a child running toward the street.

USE
RIGHT
LANE
ONLY



APPENDIX E-4

An applicant for a tractor-trailer bus driver's permit negotiates a figure-8 in the inclosed area test. The applicants for passenger car and light truck permits go through correspondingly more difficult tests.



APPENDIX E-5

Over 700 school children submitted posters in the contest culminated in this exhibit and substantial awards to the winners during the CEW Safety Show.

CONTEST

LET THE BOAT
DRIFT AWAY



STAY IN THE BOAT



STAY IN THE BOAT



ONLY ONE PERSON ON THE BOAT



ONLY ONE PERSON ON THE BOAT



ONLY ONE PERSON ON THE BOAT



LET THE BOAT DRIFT AWAY



STAY IN THE BOAT



STAY IN THE BOAT



ONLY ONE PERSON ON THE BOAT



ONLY ONE PERSON ON THE BOAT



ONLY ONE PERSON ON THE BOAT

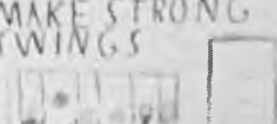

LET THE BOAT DRIFT AWAY

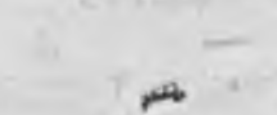

STAY IN THE BOAT



STAY IN THE BOAT



ONLY ONE PERSON ON THE BOAT



ONLY ONE PERSON ON THE BOAT



ONLY ONE PERSON ON THE BOAT



LET THE BOAT DRIFT AWAY



STAY IN THE BOAT



STAY IN THE BOAT



ONLY ONE PERSON ON THE BOAT



ONLY ONE PERSON ON THE BOAT



ONLY ONE PERSON ON THE BOAT



LET THE BOAT DRIFT AWAY

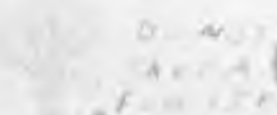

STAY IN THE BOAT



STAY IN THE BOAT



ONLY ONE PERSON ON THE BOAT



ONLY ONE PERSON ON THE BOAT

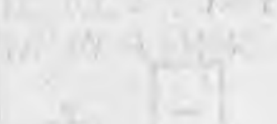

ONLY ONE PERSON ON THE BOAT



LET THE BOAT DRIFT AWAY



STAY IN THE BOAT



STAY IN THE BOAT



ONLY ONE PERSON ON THE BOAT



ONLY ONE PERSON ON THE BOAT



ONLY ONE PERSON ON THE BOAT



UP THE HILL

STRONG ROPES
MAKE STRONG
SWINGS



LET THE BOAT DRIFT AWAY



FLY KITES
IN
FAIR WEATHER



APPENDIX E-6

The Model Safety Home was an interesting and instructive exhibit which drew thousands of housewives.







APPENDIX E-7

Eight thousand of Clinton Engineer Works' workers and residents saw these varied exhibits of personal protective equipment supplied for on-the-job safety, traffic safety hints and pointers, and home and recreational hazards and precautions.

PROTECTIVE EQUIPMENT
Used By
J.A. JONES WORKERS



EYE
PROTECTION

ACID
EQUIPMENT



WELDING
EQUIPMENT



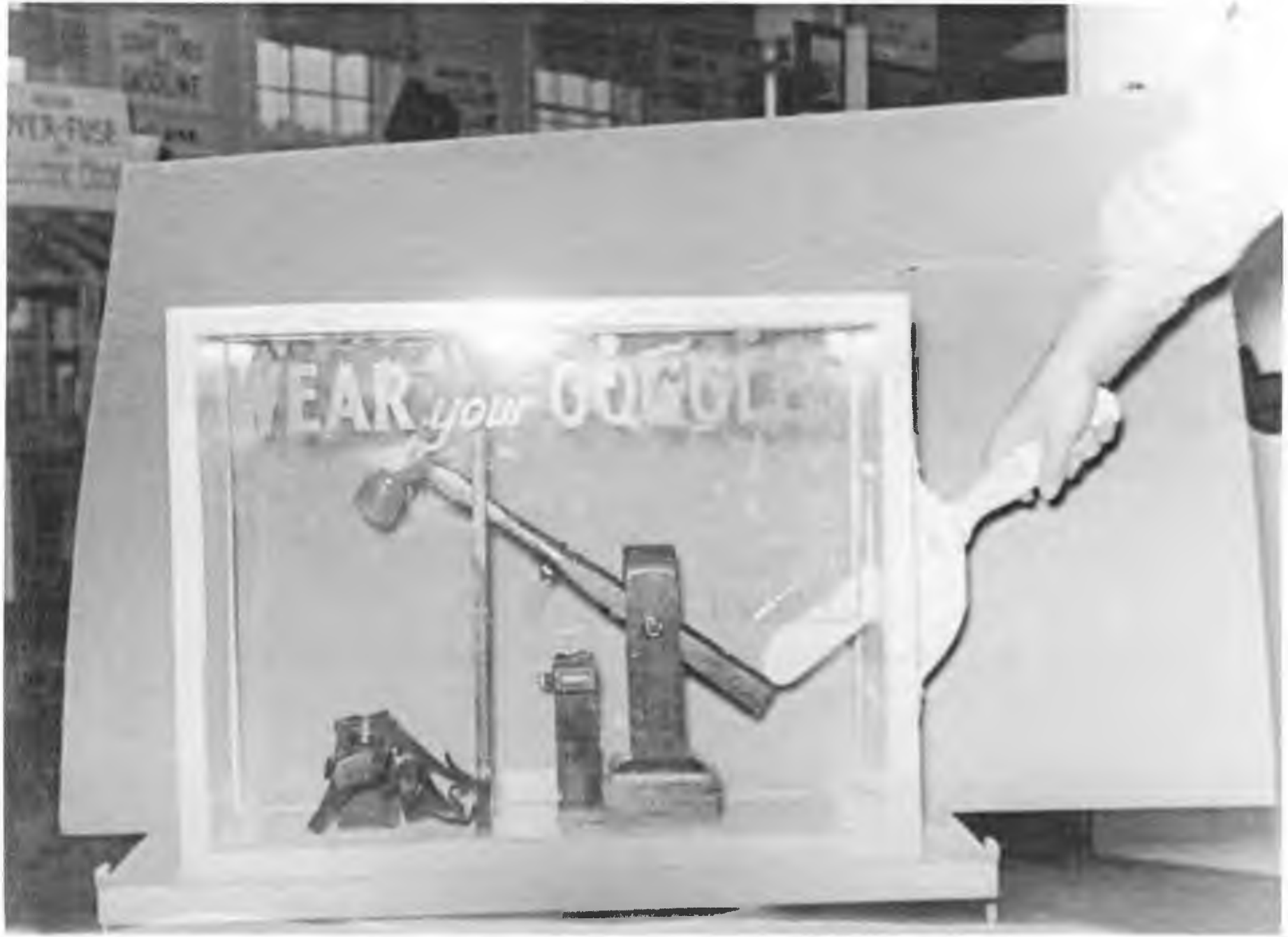

COURTESY
MINE SAFETY
APPLIANCES

INDUSTRIAL SAF

MSA RESPIRATORS

COMPO RESPIRATORS



OUTSIDE RESPIRATORS



SOME CHEMICAL SAFETY INFORMATION



MAKE OAK RIDGE AMERICAS SAFEST COMMUNITY
(TAKE ONE — FREE LITERATURE — TAKE ONE)

FILL OUT THIS FORM
YOU MAY WIN A PRIZE

TAKE IT EASY
MR. DRIVER
AND YOU'LL LIVE LONGER
BECAUSE YOU'LL BE
THINKING AS I BELIEVE TO BE
YOUR SAFETY

FILL OUT
YOU MAY

EVIL
FEEL
SAFE
ENOUGH
TO
CARELESS

DON'T INSIST ON THE
"RIGHT-OF-WAY"
BE
EXTRA CAREFUL
AT CORNERS!

BE CAREFUL
AT CORNERS

"FIT FOR
SERVICE"

GRAND PRIZE





DONT SMOKE
IN BED!
THIS OFTEN HAPPENS

VER
FIRES
LINE

USE
OLINE
EARNING

KEROSENE
D KEPT
EANS ONLY

N UP
VENTION

CLEAN UP
FIRE PREVENTION



ASOLINE IS AS DANGEROUS
DYNAMITE WITH MISUSE

KEEP *Electric Circuits* NEVER
PROPERLY FUSED OVER-FUSE
an *Electric Circuit*

CLEAN UP
FIRE PREVENTION

DONT TRY TO REPAIR
ELECTRIC TROUBLE
CALL 565

CLEAN UP
FIRE PREVENTIO



DONT SHOOT

PROMISCUOUSLY

DONT SLING
THAT BAT!

DONT FORGET
A GUN IS ALWAYS
LOADED

DONT STEP ON AN
OBJECT

You Can Easily Step Over

DONT SWIM
ALONE



DONT CAST
UNTIL YOU
CHECK *your* PARTNER



APPENDIX E-8

Thousands of Hanford Engineer Works employees and their families studied these safety exhibits. Other thousands took part in dances and shows intended to provide recreation and at the same time stimulate safety consciousness.







APPENDIX E-9

Over a thousand trailer-camp children sat spell-bound before magicians and entertainers on Saturday mornings at Clinton Engineer Works. Safety, health, and discipline were the serious themes worked in without detracting from the entertainment.



MANHATTAN DISTRICT HISTORY

SAFETY PROGRAM

APPENDIX "F"

SAFETY PROMOTION MATERIALS

<u>No.</u>	<u>Description</u>
1	"The Carpenter Foreman's Safety Responsibility" Clinton Engineer Works.
2	Safety Instruction Cards, National Safety Council.
3	"Public Safety News".
4	Selected Clippings from the Oak Ridge <u>Journal</u> , the <u>HEW Sage Sentinel</u> and <u>Richland Villager</u> .
5	Contractors' Safety Periodicals: <ul style="list-style-type: none">a. The Richland <u>Safety Beacon</u>.b. Carbide <u>Safety News</u>.c. <u>Jones-agram</u>.d. Stone & Webster <u>Timely Topics</u>.
6	Safety Films and Records Available for Loan from the U.S.E.D. Safety Branch.
7	U.S.E.D. Safety Bulletin.
8	Industrial Safety Posters.
9	Vehicle Dashboard Safety Reminders.
10	"The Safe Driver" and "The Safe Worker"

THE CARPENTER FOREMAN'S SAFETY RESPONSIBILITY

Clinton Engineer Works

In the construction work to date the accident rate for carpenters has been only a little above the average for all crafts and occupations on this project. The number of days lost per injury has been below the project average.

But carpenters are the largest craft group on this project. So, if the man-hours lost by accidents, and the inefficient, hazardous conditions which cause accidents, are to be reduced on this important project, accident prevention work must be concentrated in the carpenter crews.

The carpenter injuries which have occurred show clearly that the foremen must take further steps to protect their men, if any reduction in injuries is to take place. In four out of five carpenter accidents, the foremen had failed to inspect for hazards, failed to enforce safety regulations, or otherwise failed in his responsibilities.

The following analysis of carpenter accident causes is based on detailed reports of 91 thoroughly investigated cases occurring on this project.

Only a few of the accidents were attributed to foremen's failure to give instructions or training. It is quite apparent that supervisors have told their men how to do most jobs. Supervisors have failed by not insisting on and enforcing observance of safe practices. Where an inexperienced worker has had one instruction on a safe practice, it is obvious that the point should have been hit hard two or three times so that every workman actually follows the operating practices which have been established.

In about half the cases, foremen were not present at the scene of the work when the accident occurred. The crews which have been assigned to foremen for supervision are not large. Therefore, failure of foremen to supervise work as closely as possible is evident.

Many accidents occurred after foremen had layed out the work but had failed to inspect thoroughly for hazards. Perhaps haste to get this important job done was a factor, but "haste makes waste" on a construction job because it means hazards overlooked. After a job is layed out, the foremen must take the few seconds necessary to check for potential trouble.

Unsafe acts of workmen were contributed to four out of five accidents. Deliberate chance-taking was not very frequent. The most common fault was a failure to obey instructions. And it's the foreman's job to check, check, check, and double check, until he gets observance.

Unsafe handling, loading, and storing were frequent, as will be evident from the detailed analysis of causes:

Unsafe mechanical and physical conditions, such as improper guarding, defective equipment, and hazardous arrangement, were factors in seven out of every ten accidents. In some cases, the unsafe conditions were due to something the men had done or failed to do, but most often they were traceable to faults of supervisors.

A detailed analysis of the causes of carpenter accidents follows:

SLIPS AND STRAINS -- The largest class of injury, 23 cases and one-fourth of all carpenter injuries. Not the tools of the trade, nor the work on elevations and scaffolds, but simple slips and strains in the everyday job of carrying materials are the largest sources of carpenter injuries.

Slips While Carrying Materials. In eight cases the injured person slipped while carrying material or material slipped from his grasp. In nine other cases a person helping the injured man slipped and the injured was struck by material being carried. This is a total of 17 cases, one-fifth of all carpenter injuries.

In eight cases lack of teamwork and lack of knowledge of proper lifting procedure were assigned as causes, and were attributed to inexperience. Workmen should be thoroughly instructed in safe lifting, and before undertaking a job should be told exactly what is to be carried, how carried, the route, and the agreed-upon signals for lifting and lowering the material.

Four slips were attributed to slippery footing. A slippery surface which can be crossed without trouble when simply walking may result in an accident if crossed while carrying heavy materials because balance and stability are affected by the load carried.

In four cases insufficient help was used on the job. The tempting savings of time by doing a job with insufficient help, or with makeshift equipment, are often lost by injuries to workmen, damage to materials, and inefficiencies in moving heavy materials from one place to another.

One carpenter attempted to save a few seconds by taking a shortcut with lumber on his shoulder. When he had straddled a handrail, his foot slipped and the resulting injury cost seven days disability. He would have saved days by using the walkway which had been provided.

Other Slips. In two cases men with mud on their shoes slipped on smooth lumber or steel piling. It is impossible to keep out of the mud on this job and the small number of cases attributed to slippery footing should probably be accepted as evidence of the care which has gone into overcoming this hazard.

STRAINS (except slips included above) -- There have been six cases of strain with no slipping involved, and every one of the cases resulted in serious back or side strains, or hernia.

Three cases resulted from using too few men on the job. In the other three cases there was sufficient help but the injured men strained themselves trying to carry more than their share.

HOW TO HANDLE MATERIALS SAFELY -- If the men are taught the following simple rules, and if supervisors enforce the rules, the large number of carpenter injuries on this project can be sharply cut.

1. Before carrying materials, take a look around and pick a safe route. Avoid makeshift walkways, slippery places, congestion and cranes or other heavy equipment.
2. There are a lot of heavy materials to be carried and they'll require help. Get enough men to do the job safely.
3. Watch for splinters and nails. Wear gloves.
4. Be sure of your footing before making a lift. A slip in lifting may cause a painful strain.
5. Take a good firm grip on the object.
6. Lift with your leg muscles -- not your back.
7. Teamwork is mighty important in carrying material with other men. Lift together. If you have to set the load down, for example, to change your grip, tell the other men. Keep in step with the other men. In carrying a load on your shoulders, both you and the other men should carry with the same shoulder, and keep in step.

FALLING AND FLYING OBJECTS -- eleven cases. Most of these cases occurred in wrecking forms and similar work. Failure to clean up as the work progressed resulted in two injuries. Improper location of scaffold produced another. In one case the man failed to step back far enough and was struck by a falling timber.

Two injuries resulted from carelessly throwing or dropping T-jacks.

One accident was caused by a defective 2 by 4 stud being used to raise a form.

There were four eye injuries, two of which occurred in wrecking forms. In two of the four cases, the safety engineer stated goggles should have been worn for the work. Every eye case, no matter how slight, should be treated at the first aid station.

FALLS

Scaffolds. Eleven injuries occurred in working on scaffolds or where scaffolds should have been provided.

In nine of the eleven cases, the scaffold provisions of the Corps of Engineers Safety Requirements were violated. Two scaffolds lacked guard and intermediate rails. In two cases, planking was not secured -- the boards slipped in one of these and the other had an overhang. One scaffold pulled loose from the wall. A putlog of another scaffold was defective and broke, letting the man fall fourteen feet to a concrete floor.

In one case, a worker was wrecking forms and fell to the ground because no scaffold had been provided. And in two other cases makeshift staging was used instead of proper scaffolds.

Two scaffold accidents resulted from outright unsafe acts -- climbing on scaffold and construction members rather than ladders which were available.

Ladders -- two cases, in addition to the two scaffold accidents which resulted from failure to use the ladders provided. In one case, a man was attempting to carry a 40 pound nail keg up a ladder, missed his hand hold and fell, mechanical hoisting equipment should have been used. The worker's foot slipped from a rung in the second ladder case.

Openings and Elevations -- ten accidents. Three men fell into unguarded openings. One other man climbed over a barricade and fell. So supervisors must not only order barricades and guard rails erected, but also keep men from climbing over them.

Two men fell through joists because temporary walkways or flooring had not been provided.

Single-plank, makeshift walkways over excavations resulted in two serious accidents.

One accident was caused primarily by lack of illumination, which was also a contributing factor in two of the accidents above.

One man fell from a small form. It would not have been necessary to stand on the form to do the job.

TOOLS -- twelve injuries.

Power Saws -- five accidents, two of them finger amputations. An unguarded skill saw was permitted to remain in use after it had been called to the supervisor's attention.

A man failed to prepare a timber for sawing by removing a 2 by 4 block nailed to it. When the block struck the table, he lifted the timber and pushed it with his hip, forcing his hand against the saw.

A saw hit a knot; the piece kicked back. Anti-kick-back dogs were lacking. The man should have stood to one side while operating the saw.

One worker was removing a piece from the saw table when the wood was caught by the saw, drawing his hand against the blade. He should not have been wearing gloves. And push sticks should be used whenever possible.

The fifth power saw accident resulted from lack of teamwork between the saw operator and an inexperienced helper while cutting a plank. The helper pushed the plank, carrying the operator's hand against the blade.

Hand Saws -- four cases

A dull saw jumped, cutting a man's thumb.

One man let the cut-off end of a 2 by 4 drop on his toe. Another worked over to the end of a sawhorse which tipped and fell, the lumber striking his foot.

Two men tried to notch a piece of siding at the same time. Vibration caused a saw to jump and cut one of the men.

Hatchets -- In two cases the hatchet was deflected by a nearby brace and by a chip on the blade.

Sledge -- One man inadvertently put his hand on top of a stake which he was holding and had his thumb fractured by a blow of the sledge.

EXCAVATIONS

Clean up -- Work in excavations must ordinarily be done under somewhat congested conditions. But that makes a failure to take reasonable steps to clean up and prepare a working area all the more inexcusable. The failure caused two accidents.

Sloping Banks -- Failure of a Dirt Foreman to have banks properly sloped resulted in injury to one carpenter.

NAILS

One man stepped on a nail. The housekeeping was poor and was the direct cause of this accident. However, housekeeping on this job has been above average generally, witnessed by the fact that there's been only one carpenter injury attributable to nails underfoot.

Another man was pulling off a sill nailed to framing. A hard pull loosened the sill, but drove a nail into his ankle. Proper tools should have been used.

CRANES

Two men were injured by crane loads. Some responsibility rested with the crane crew in each case. But every man has his own personal responsibility of keeping in the clear when working near cranes.

INFECTIONS

There were seven minor injuries - splinters, nail punctures, etc., which would have had no serious complications if proper first aid had been obtained. In addition, there were three other accidents, described above, which were made more severe through failure to get first aid. This was a total of 10 cases - more than one-tenth of the carpenter injury toll.

MISCELLANEOUS

One man tripped on the cuff of his pants and fell downstairs. Long, rolled-up pants legs were at fault.

A carpenter was struck by a bolt dropped by a structural iron-worker because workers had not been excluded from a hazardous area.

One injury resulted from improper cranking of a motor.

The mad rush for the clock alleys produced one injury when two workers collided violently.

Two workers were injured in transportation accidents. In one case a bench was not fastened and tipped when the truck hit a rough place in the road. The other carpenter was injured in an over-crowded pick-up truck; a fellow worker stepped on his ankle.

THE FOREMAN'S JOB

What are the things that put a good foreman ahead of his crew? He's a top-notch craftsman, of course. He has the "Know how". But the two things which make or break a foreman are his ability to plan an efficient job and his ability to get the plan across to his men.

Safety and efficiency go hand in hand. A good safety record reflects a foreman's ability. Mistakes, waste, and accident hazards will not crop up if the supervisor has gone over the work thoroughly in his own mind, checking each step to see what could go wrong and finding a way to get around each and every potential trouble.

Prepared by
Safety-Accident Prevention Section
Manhattan District
December, 1943.

CIRCULAR SAW OPERATION

1. Before starting the saw, make sure that all guards are in place and operative.
2. Always use a push stick to push narrow pieces through between the saw and the gage.
3. Avoid "kick-backs" by standing to one side of the saw—not in line with it.
4. Keep material of any kind from accumulating on the saw table.
5. If the saw is dull or needs setting, if it heats up and runs "snaky," if it is warped or lumpy, or if it has teeth filed to a backward pitch, get a saw in good condition.
6. Do not attempt to straighten a warped or lumpy saw unless you have had special training in that kind of work.
7. In filing gullets, see that they are all nicely rounded to prevent cracks.
8. Any saw that has started to crack should be replaced; "doctoring" it by drilling it may prove very dangerous.
9. Sawdust underfoot on the floor can be very slippery; keep your workplace clean.
10. Never leave the saw with power turned on.



 SAFETY INSTRUCTION CARD No. 54
(Revised Mar., 1937)

Lifting Capacity of Tackle

Wooden Shell Blocks with Manila Rope

Maximum Safe Load in Pounds	RIGGING 1" Manila Rope	Maximum Safe Load in Pounds	RIGGING 1 1/4" Manila Rope
2,975	SINGLE 2 Parts	4,450	SINGLE 2 Parts
4,050	DOUBLE 3 Parts	6,075	SINGLE 3 Parts
4,900	DOUBLE 4 Parts	7,375	DOUBLE 4 Parts
5,575	TRIPLE 5 Parts	8,375	DOUBLE 5 Parts
	DOUBLE 6 Parts	9,125	TRIPLE 6 Parts

Use not less than 12" blocks for 1" and 1 1/4" rope.

These tables are for new manila rope made to Federal Specifications No. T — R — 601, and are based on a factor of safety of 5. Where the service subjects the rope to conditions which accelerate rope deterioration, or if the rope has been in service 6 months, use factor of safety of 10, and decrease loads accordingly.

These maximum loads are only for tackle as shown. If lead line is snatched or passes over additional sheaves, maximum loads must be decreased accordingly.

 SAFETY INSTRUCTION CARD No. 61
Revised Oct. 1934

Operation of Power Trucks

1. At the beginning of each shift or if you change to another truck try out the brakes first.
2. Keep your truck under control. Speeding will only get you into trouble.
3. In crowded aisles and when approaching intersecting aisles, drive slowly and cautiously.
4. Never lounge on the truck while it is in motion. Face in the direction of travel and be alert for danger, particularly when backing up.
5. Never leave truck without shutting off the power and removing the switch key or control handle.
6. Make your warning signals heard but use them only when necessary.
7. Keep a safe stopping distance from other trucks or pedestrians. Always give a pedestrian the benefit of the doubt, he may be deaf.
8. When approaching an elevator, bring truck to a full stop at least six feet from the gate and set the brakes. Walk to the signal button to ring for the elevator. Do not start truck until elevator has stopped. Be sure total weight of truck and load does not exceed safe capacity of elevator.
9. Never haul loads that are not properly piled or trimmed for clearance.
10. Keep to the right of aisles.
11. Do not permit unauthorized persons to ride on truck or trailer.
12. Never tamper with the truck mechanism.

 SAFETY INSTRUCTION CARD No. 43

Grinding Wheel Flange Dimensions

Straight-Sided Wheels

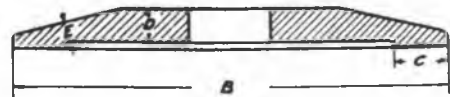

Minimum Dimensions for Straight Flanges for Use with Straight Sided Abrasive Wheels with Small Holes Which Fit Directly on the Spindle or Machine Arbor.

Diam of Wheel	B Min Outside Diam of Flanges	C Radial Width of Bearing Surface		D Min. Thickness of Flange at Bore	E Min. Thickness of Flange at Edge of Recess
		Min	Max		
Inches	Inches	Inches	Inches	Inches	Inches
1	3/8	1/8	1/8	3/8	3/8
2	3/4	1/8	1/8	3/8	3/8
3	1	1/8	1/8	3/8	3/8
4	1 1/4	3/8	3/8	3/8	3/8
5	1 1/2	3/8	3/8	3/8	3/8
6	2	3/8	3/8	3/8	3/8
8	3	3/8	3/8	3/8	3/8
10	3 1/2	3/8	3/8	3/8	3/8
12	4	3/8	3/8	3/8	3/8
14	4 1/2	3/8	3/8	3/8	3/8
16	5 1/2	1/2	1	3/8	3/8
18	6	1/2	1	3/8	3/8
20	7	3/8	1 1/4	3/8	3/8
22	7 1/2	3/8	1 1/4	3/8	3/8
24	8	3/8	1 1/4	3/8	3/8
26	8 1/2	3/8	1 1/4	3/8	3/8
28	10	3/8	1 1/2	3/8	3/8
30	10	3/8	1 1/2	3/8	3/8
36	12	1	2	3/8	3/8

(NOTE: These are not protection flanges and should only be used in connection with proper protection hoods.)

 SAFETY INSTRUCTION CARD No. 59

The material in this publication is for the information of the editors of the contractors' house organs and they are urged to reprint any or all material.

Published by U. S. E. D. Safety Branch in the interest of Off-the-job Safety.

PAVEMENT MARKING IN PROGRESS

Pavement marking of newly paved roads has started. Striping of Bethel Valley Road beginning at Solway Gate and west to Scarboro is now in progress. From there the striping will be started on Scarboro Road. Other striping and cross-walk markings will be started in the near future.

Striping paint reflectorized with tiny glass spheres will be applied on all main roads. This reflectorizing helps immensely in seeing the line at night.

NEW TRAFFIC SIGNALS

Work has been started on the installation of seven new traffic signals at CEW.

One of the new signals has been installed at the intersection of Scarboro Road and Oak Ridge Turnpike. Other signals will be installed at the following intersections:

Gamble Valley Road and Oak Ridge Turnpike
Robertsville Road and Oak Ridge Turnpike
E. Division Road and Oak Ridge Turnpike
New York, Pennsylvania and Tennessee Avenues
Georgia Avenue and Tennessee Avenue
Gamble Valley, Scarboro and Sawmill Roads

SAFETY OFF THE JOB

There is no quitting time for Safety! It doesn't stop at the quitting whistle or go with your time card at the clock alleys. Do you know that your chances of injury in an accident are more than twice as great away from work as they are on the job? No matter how safely you've worked during the day, you are still liable to injury off the job. When you leave the job for home and when you come to work each day, use the greatest care in crossing streets and highways, in boarding and alighting from busses and in driving your car.

Whether you drive an automobile or walk, observe all street signs and traffic signals; never take a chance that may lead to an accident.

Be alert, an accident would mean loss of wages to you and grief to your family.

SUNBURN

Now that vacation time is upon us, we all have an urge to get that beautiful sun tan. Sun-tan is very beneficial to the body, if taken in small doses. Get sun tanned gradually, there is little or no excuse for taking the chance of a serious burn that will put you flat on your back in agonizing discomfort.

Expose yourself to the sun for short periods at a time until your skin has a chance to adjust itself or, in other words, until nature protects you with a good coat of tan.

A good coating of "Sunburn" oil or ointment, well bubbled in, before exposing yourself will help to prevent burning.

Women Inspecting Model Trailer



(Journal Photo By Westcott)

SAFETY HINTS—For trailer residents are outlined by Matthew B. Long, of the Oak Ridge Fire Prevention Bureau. The Model Trailer, which is touring trailer camps, is staffed by Town Hostesses who demonstrate to trailer residents ways and means of keeping their homes safe and sanitary. It will be in Middletown this week.

TWO TRAILER CAMP PLAYGROUNDS IN OPERATION; OTHERS WILL OPEN

Two playgrounds in Trailer Camps are now open to all children as the first step in a wide program which will ultimately affect all children on the area, it was announced this week by Temple Jarrell, director of Physical Recreation for the Oak Ridge Recreation and Welfare Association.

The playgrounds, one in Gamble Valley and one in Middletown, will be open each day from 2:30 to 5:00 PM. On Saturday, playgrounds will be open from 1:00 to 5:00 PM.

National Safety Council Holds Course For MP

Local Auxiliary Military Police have secured the services of Richard O. Bennett, Police Traffic Training Consultant of the National Safety Council, to conduct a short course in traffic direction. Major L. R. Block, Chief Guard Officer, announced this week.

To provide for maximum attendance by the Traffic Police, Bennett will conduct two classes. In this way, Major Block explained, there will be no interruption in traffic control during class periods.

Efficiency and safety depend on keeping tools and wits sharpened.

The Gamble Valley play center is located at Miami Way and Berkeley Avenue, and the Middletown at Oak Ridge Turnpike and Lark Avenue.

Supervision of the playgrounds is in charge of Shep Lauter, with Margaret Stewart as assistant.

Safety Course Begins Here On December 18

G. M. Kintz, Supervising Engineer, U. S. Bureau of Mines, Dallas, Texas, will conduct a course in the Safe Handling of Inflammable and Toxic Substances for all safety personnel at CEW during the week of December 18. All operating companies will send safety inspectors and engineers and representatives of fire prevention and health organizations to attend the sixteen hour course being sponsored by the USED Safety Section. Estimated attendance will be approximately 100.

The course will be held at Jefferson Recreation Hall. The physical and chemical characteristics, Toxicity and Hazards, Physiological effects and protection against the many different gases and substances commonly handled in industry today will be completely demonstrated and discussed.

Recreation Units are being formed for younger children all over the project, with supervisors in charge at all times. They will be known as Jackson Square, East Town, Scarboro, and exact locations will be announced later. The program has been formulated with the idea in mind of emphasizing the development of intra-unit programs, Jarrell said. Intra-center, inter-center, and city-wide activities will be limited to a few major events.

The playtime program for elementary school boys, under the direction of Shep Lauter, will be held from 1:00 to 4:00 PM each Saturday in the gyms of each school. Each school on the area will have two supervisors with all schools sponsoring basketball teams. Plans are now underway for an elementary school basketball tournament.

11 JANUARY 1945

SAFETY ON THE MARCH

ONE THING some of us forget is that an "off-the-job" injury prevents us from working just as effectively as being injured on the job. Falling downstairs at home may just as readily cause a disabling sprain or fracture as falling from a scaffold or truck bed on the job. Using kerosene at home to start a fire may burn you just the same as using it for that purpose on the job.

During the year of 1945, let's put forth more effort to eliminate home accidents.

"YOU'D BETTER Be Panic Proof" is the title of an article originally published in the Liberty Magazine and condensed in the December 1944 issue of the Reader's Digest, and is an article which could be read to advantage by every resident of Oak Ridge.

The material in the article was picked at random and the scenes mentioned could be repeated here. Ask yourself this question, how would you react to a fire in a public building? Would you have your exit located and calmly walk to the exit or would you lose your head to trample and be trampled in the crowd? Always be cool in an emergency, it will set an example to others and help to save them and yourself.

A GOOD HOME fire extinguisher is ordinary baking soda. Baking soda thrown at the base of a flame caused by cooking fires, flash fire in gasoline cooking stoves or oil heated equipment will quickly extinguish the fire if it hasn't a serious start. Flour or corn starch will not extinguish fires. They may cause an explosion.

22 FEBRUARY 1945



SAFETY SUGGESTIONS —Are coming in thick and fast in the J. A. Jones contest for workers' wives. The first was turned in by Mrs. James H. O'Dell, above, to D. N. Kelly, Jones safety man. See story below.

Mrs. James H. O'Dell Makes Initial Suggestion In Jones Safety Contest

Mrs. James H. O'Dell, wife of a J. A. Jones carpenter foreman, a schoolteacher in Wheat School, was first to submit an entry in the novel safety contest for J. A. Jones workers'

wives, which will close on March 21 at midnight. The contest, open to wives in the K-25 area only, offers fifteen prizes in War Bonds and Stamps.

Mrs. O'Dell, in submitting her entry, said that she and her husband both realize the value of safety precautions. "Mr. O'Dell has been handling crews for thirty-five years without a serious accident to the men, and has operated a twenty-man crew on this area for eleven months without a disabling injury," she stated.

Complete rules of the safety contest may be obtained from the J. A. Jones Safety Department, Box 229, Knoxville, Tenn.

An economical safeguard for winter driving is a putty knife or razor blade carried in the car to scrape frost from the windows. A frosty windshield is a definite driving hazard in view of the fact it reduces vision and causes excessive glare in night driving. A few minutes spent in scraping frost from the windows may prevent an accident.

Office Safety At Half Mark

Out front with eight emblems each are three departments this week in the Office Safety Contest. The top-notchers are Richland Office, Engineering, Engineering Services and Investigation.

Pushing to the fore are five other offices, Feeding Facilities of Hanford Housing, Concrete, Methods and Procedures, Public Health and Multilith.

Other offices have all earned six emblems each for the Office Safety Flag, which, the Office Safety Supervisor announced, puts each department "over the top" in the fourth week of the contest and qualifies the supervisor to receive the Recognition Safety Award.

"But," Safety warned, "these supervision awards will be given 'on probation' until the end of the contest January 1, for any office that slips may still find itself with 'minus' emblems."

With five more weeks left in the contest, Safety complimented all offices on their participation in the contest and urged continued Safety suggestions from the groups.

24 NOVEMBER 1944

Traffic Care Safety Rule

Concern for traffic hazards caused by winter weather conditions prompted Safety to bear down this week on the principal points to be observed in preventing accidents on the road.

Among the important traffic safety items, they pointed out, were: leave home from 20 or 30 minutes earlier than you do in summer; clean your windshield and all windows of dew and frost before starting to drive; use good judgment in your driving speed, and keep two windows open at least a crack to avoid possibility of concentration of carbon monoxide gas in vehicle.

For pedestrians, these considerations were suggested for watching: frost or ice on running boards and steps; wet and icy sidewalks; always cross at designated crossings, and avoid walking in front of or around busses.

For everyday care, Safety reminded motorists that failure to give proper hand signals is a frequent accident cause. The three main points to be observed in automobile driving are: hand straight out for left turn, down for stop and up at right angle for right turn.

Safety Leaders



Standing high in the Office Safety Contest is the Public Health Department. Emblems for the week on the office Safety Flag are being put on by Lucille Brownell, Health Educator. And admiring the process and cheering from the sidelines are L. G. Koch, Sanitary Engineer; Virginia Secor, Department Secretary, and Janis Gerking, Supervisor of Public Health Nurses.

1 DECEMBER 1944

Emphasis on Safe Driving

A display of wrecked and smashed cars, to be held on Kadlec Plaza, will be the grim warning to reckless motorists, as the drive to "Injure No More in '44" marches into its last month.

Further emphasizing the intense traffic safety program, movies on "highway safety" are to be shown in the conference room of the Training and Relations Building, together with the regular series of war communiques shown nightly at 7:45. Also in connection with the last quarter safety drive, terse warnings that every traffic violation on the Project will be prosecuted to the full extent of the law have been issued.

To insure against careless driving, every member of the Patrol Department has been instructed to act in every case of traffic violation. These violations include neglect of proper signals and speeding, as well as other careless practices. Pedestrians will be held for infractions of safety regulations, in the same manner as are haphazard drivers.

In addition to avoiding actual violations, motorists are urged to increase alertness at all points of danger, such as intersections, railroad crossings, and winding roads. Safety officials add repeated warnings against speeding through fog or on icy pavements.

Give Firearms Care Warning

According to the accident facts issued by the National Safety Council, there were in this country 2,700 accidental deaths from firearms in 1942. The death rate per 100,000 population was 20, which means that for every 100,000 persons in the United States, two accidentally lost their lives from firearms.

Most of these deaths occurred in the fall, when the hunting season is open, but not all of these deaths occurred in the field. Twenty-two percent, 504 deaths, occurred in the home through careless handling of firearms.

Many Richland Village homes have one or more guns. Therefore, serious consideration should be

given to the safe handling of firearms, both in the home and in the field.

The Safety Division reports two recent instances in the Village where guns were accidentally discharged, fortunately without injury. In the first case one person was showing another person how the gun operated. The gun accidentally discharged. The charge went through the living room wall and into the house next door. This was one of those instances when the person thought the gun was not loaded.

In another instance, the gun accidentally discharged when a person was in the act of cleaning it. Again, the person thought the gun was not loaded.

SAFETY PAYS

THE VILLAGER
14 JUNE 1945

Swimming Courses To Be Offered Here; Meeting Tomorrow

Villagers, both young and old, will be given an opportunity to learn to swim or improve their swimming ability if enough interest is shown in a series of classes being organized by O. A. Coppock, acting water safety chairman for the American Red Cross here. A mass meeting of those interested has been called by Coppock for tomorrow morning (Friday) at ten o'clock in the Lewis and Clark gymnasium.

Among the classes to be made available are instruction for beginners, intermediate, advanced, junior life saving and senior life saving. It was announced. Because of a need for qualified water safety instructors, Coppock indicated that a refresher course for those who have held certificates which are not now in force, may be held. Emphasis in all courses will be on strong swimming, that is, to teach students to swim safely and without fear, rather than with speed.

According to Coppock, 40 percent of those who drown, do so within a few feet of shallow water, and in twenty minutes he can teach anyone to float long enough to keep himself safe until help arrives. In four hours, almost anyone can be taught to swim 25 yards. The swimmer can then alternately swim and float for long



SAFETY INFO

H.E.W. TO BE USED AT MONDAY TOOL BOX MEETING NOV. 27-44

STOP TRAFFIC ACCIDENTS!



HANFORD AREA COOKS "200 WEST ROOSTER"

In reply to the big sign advertising 200 West Area's record of 2,000,000 safe man-hours which was placed in the Hanford Area, men in Hanford have resolved to "COOK THAT CHICKEN with a bigger and better record". Actually a large bird WAS cooked and presented at a Hanford Safety Meeting as a door prize.

" I ' L L S E E H . E . W . T H R U "

Demonstrating their enthusiasm and sympathy with the war effort, lots of people on this project are wearing buttons with the caption - "I'LL SEE H. E. W. THROUGH TILL FINAL VICTORY. WILL YOU?" All employees are urged to stay on the job until their part of construction is finished or until the last Jap commits "Hara-kiri". PLEDGE TO SEE H. E. W. THRU!

TRAFFIC VIOLATORS - PROJECT ENEMY No.

Injuries involving vehicles are by far the most costly on this project. To safeguard the people on this project and to insure our World's Safety Record a DRIVE-IS ON to STOP TRAFFIC ACCIDENTS!

EVERY SUPERVISOR is urged to take EVERY POSSIBLE STEP to rid this project of traffic violators.

EVERY ENGINEER is expected to DEVOTE EXTRAORDINARY EFFORT to the control of clock alley traffic and to discourage careless driving in the area.

EVERY FOREMAN is requested to devote SUFFICIENT TIME, in his gang meetings and in his contacts with the men in his gang, to make sure that they will not be involved in careless driving.

EVERY MEMBER OF PATROL DEPT. IS INSTRUCTED TO STOP ALL VIOLATORS OF TRAFFIC RULES AND TO SEE THAT THEY ARE BROUGHT TO JUSTICE.

EVERY DRIVER AND PEDESTRIAN IS URGENTLY ADVISED TO TAKE EVERY POSSIBLE PRECAUTION AND TO OBEY ALL TRAFFIC RULES.

VIOLATORS ARE PAYING FULL PENALTY

Some people believe that because this is a government project they can violate traffic rules without fear of penalty.

THIS IS NOT TRUE! EVERY TRAFFIC VIOLATOR IS BEING PROSECUTED TO THE FULL EXTENT OF THE LAW. **DON'T COMMIT A TRAFFIC ACCIDENT!**

Traffic Violators Kill 75 Daily in U.S.A.



CRAFT GUIDE



CARPENTER

STATUS OF WORK NECESSITATES THE PROMPT CLEAN-UP OF SCRAP MATERIAL.

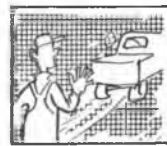

CONCRETE & MASONRY

CONCRETE TRUCK SIGNAL-MAN IS TO STAY WHERE DRIVER CAN SEE HIM AT ALL TIMES TO PREVENT TRUCK FROM GETTING ON SOFT SHOULDER OR TOO CLOSE TO EMBANKMENT. HAVE BLOCK READY TO CHOCK THE TRUCK.

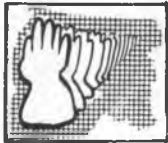

LABOR

HANDLE MATERIAL CAREFULLY - WEAR GLOVES.



EARTHWORKS

EXTRA CAUTION IS TO BE TAKEN BY POWER PATROL AT INTERSECTIONS AND RAILROAD CROSSINGS.

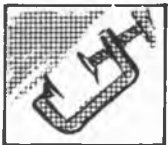

MECHANICAL

ALWAYS USE C-CLAMP ON VISE WHEN DRILLING.



PIPE

TOO MANY EYE INJURIES OCCUR TO 100-F PIPE MEN. PIPE MEN AT 100-F ARE OUT TO IMPROVE ON 100-D'S RECORD.



STRUCTURAL

USE EXTREME CARE WHEN WALKING ON ICY CAT-WALKS. BETTER USE OF OVERHEAD WORK SIGNS AND BARRICADES IS RECOMMENDED.



ELECTRICAL

WEAR WARM CLOTHING TO AVOID COIDS.

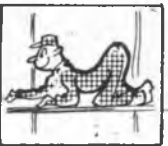

RE-STEEL

SCAFFOLD MEN AND ROD-SETTERS SHOULD USE EXTREME CARE ON FROSTY SCAFFOLDS.

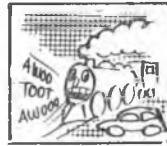

RAILROADS

ENGINEERS SHOULD GIVE ADDITIONAL WARNINGS WHEN APPROACHING CROSSINGS DUE TO SEASONAL POOR VISIBILITY.



PAINT

WEAR PROPER CLOTHING -- SLEEVES DOWN TO PREVENT BURNS FROM HOT PIPES.



UTILITIES

WATCH OUT FOR NAILS WHEN DISMANTLING BUILDINGS. WEAR GLOVES.



TRANSPORTATION

ICY ROADS WILL REQUIRE GREATER CARE WHILE DRIVING. KNOW YOUR STOPPING DISTANCE.



LUMP SUM CONTRACTORS

BETTER CLEAN-UP IS NEEDED.
A CLEAN JOB IS A SAFE JOB



WEEKLY HAZARD FORECAST

YOUR AREA SAFETY ENGINEER ADVISES

MILAM'S AREA

Heavy rigging continues in 221-U Bldg. extreme care should be taken in handling cell equipment. Usual painting precautions are to be observed in 224-U Bldg. Demolition of temporary buildings will continue. Caution men against protruding nails; falls from buildings and other hazards associated with this type of work.

T. EDMUNDS, Area Safety Supervisor

OLSEN'S AREA

Employees not assigned are to keep clear of scaffolds on west side of 272 Building. Hammering of pipe and equipment is a constant hazard; keep your mind on your job; stay on the alert and watch out for other employees. Extreme care should be taken when seaming out pipe - only one man assigned to valves. Use sand on slippery walkways.

B. A. KING, Area Safety Supervisor

WILLIAMSON'S AREA

Use extreme care when transferring equipment into buildings. Avoid acid-wear protective equipment.

A. R. STEVENS, Area Safety Supervisor

HANFORD AREA

Do not relax on the Safety Program. With shorter days, more care and attention should be given to Safety. Check tools and equipment for wear; replace at once if needed. Dress for colder weather. Check all fires for Safety.

D. J. BEATTY, Area Safety Supervisor

NEWCOMBE'S AREA

Keep clear of open ditches in 221 B. Use bridges and stairways when working around those areas. Avoid open cells and hot steam lines in this area. Do not pass material over any cell as men are working in them. Secure tools and materials. Do not work over others. Heavy grading is in progress in the power area. KEEP CLEAR.

J. H. STRICKER, Area Safety Supervisor

CROWLEY'S AREA

General clean-up, painting, and testing continues throughout this area. Extreme care should be taken in regard to proper use of Danger Tags.

R. BRADFORD, Area Safety Supervisor

LITCHFIELD'S AREA

Roofing continues throughout this area. Caution all men to stay clear of kettles and hoists. Steam will be on in 1700 Bldg. Caution men about hot radiators and pipes. There is inadequate clearance on some overhead steam lines. Caution truck drivers to follow regular marked roads and detours. The 151 Bldg. has been energized. Only men assigned to this area are permitted inside the fence.

W. B. STANLEY, Area Safety Supervisor

RICHLAND AREA

Irrigation lines are being put in throughout the Village. Watch for open ditches. Caution all children against looking at welding arcs.

A. R. STEVENS, Area Safety Supervisor

RECENT MAJOR INJURIES

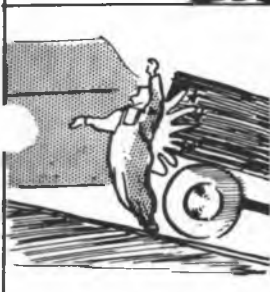

CAUSE: TRUCK DRIVER STRUCK UTILITIES SIGNALMAN WHEN HE UNEXPECTEDLY BACKED UP THE RAMP THE SECOND TIME

CURE: 1. STAY ON THE ALERT.
2. BE SURE OF CLEARANCE BEFORE BACKING

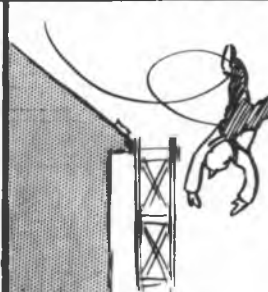

CAUSE: S.H.W. EMPLOYEE SLID DOWN FROSTY ROOF OF A CHURCH. (TOE BOARD & SCAFFOLD WERE PROVIDED!)

CURE: STAY OFF FROSTY ROOFS

GANG MEETING SLATE

MATERIAL FOR YOUR TOOL BOX MEETING



24,500 SOLDIERS
KILLED AT WAR
FRONT IN 1913

Discuss Injury Causes!

For every U.S. soldier killed, FOUR home front workers die in vain because of accidents! A good foreman can prevent accidents in his gang by learning the CAUSES and then taking steps to prevent their recurrence. Show your men WHY.



90,900 WORKMEN
KILLED IN ACCIDENTS
AT HOME FRONT IN 1913

41% of all UNSAFE PRACTICES at H.E.W. are of a nature to cause FALLS!

21% of all H.E.W. injuries are from FALLS!
FALLS KILL 69 DAILY!

TRAFFIC VIOLATIONS are probably the most common unsafe practice at H.E.W.

TRAFFIC VIOLATIONS are the greatest source of injury at H.E.W. 23% of cost.

9% of unsafe acts was FAILURE TO WEAR GOGGLES.

51% of all EYE injuries occur to the man who is just PASSING BY the hazardous work.

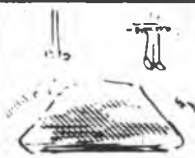

THIS



CAUSES THIS



THIS



CAUSES THIS



THIS



CAUSES THIS

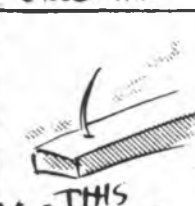

13% of H.E.W. UNSAFE PRACTICES was ABUSE OF FIRE EQUIPMENT!

U.S. FIRE LOSS total.
\$314,000,000.00 in
1942 !

POOR HOUSEKEEPING accounted for 5% of UNSAFE PRACTICES NOTED.

7% of all H.E.W. injuries result from stepping on or striking against.

TOO MANY MEN ON THIS PROJECT DO NOT KNOW HOW TO LIFT PROPERLY!

40% of all H.E.W. injuries occurred to the TRUNK.

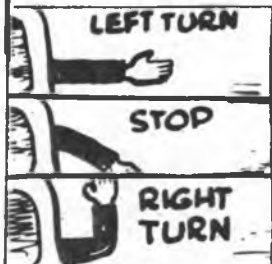

MINOR INJURIES- THE FOREMAN'S OPPORTUNITY

For every MAJOR injury there is an average of 30 MINOR injuries and 300 accidents that involve NO INJURY AT ALL. The wise foreman regards those "MINOR ACCIDENTS" as seriously as though they had resulted in MAJORS!

MINOR INJURIES
What are you doing to prevent recurrence?

CARBIDE

Safety

NEWS

VOLUME 1

AUGUST 1945

NUMBER 8



THE SUCCESS OF THE SAFETY PROGRAM IN THIS PLANT DEPENDS ON ACTIONS OF BOTH THE EMPLOYEE AND EMPLOYER. SAFETY IS EVERYBODY'S BUSINESS. THE EMPLOYER IS RESPONSIBLE FOR PROVIDING SAFE WORKING CONDITIONS, SAFE WORKING PROCEDURES, PERSONAL PROTECTIVE EQUIPMENT AND FOR ALLOTING TIME NECESSARY TO MAKE THE SAFETY PROGRAM A SUCCESS. EACH EMPLOYEE IS HELD RESPONSIBLE FOR SAFETY FUNCTIONS IN THIS PLANT TO THE SAME EXTENT THAT HE IS RESPONSIBLE FOR PLANT OPERATIONS.

THERE IS NO JOB SO IMPORTANT OR SERVICE SO URGENT BUT WHAT IT CAN BE DONE THE SAFE WAY. NO EMPLOYEE IS REQUIRED TO PERFORM ANY JOB THAT CANNOT BE DONE SAFELY.

LOST GROUND CAN ALWAYS BE REGAINED BUT LOST TIME—NEVER.

H. D. KINSEY
General Superintendent

NOT TO BE TAKEN OR MAILED FROM AREA

F56



ACTIVE PARTICIPATION IN A SAFETY PROGRAM IS ONE OF THE SOUNDEST BUSINESS INVESTMENTS ANY PERSON CAN MAKE. THE MANY BENEFITS AFFORDED ARE ALL TO OUR PERSONAL ADVANTAGE AND THE COST TO OURSELVES IS AS FREE AS THE WIND. WHEN ANY EMPLOYEE IS INJURED FROM FAILURE TO PARTICIPATE ACTIVELY IN THE SAFETY PROGRAM, HIS FAMILY, HIS EMPLOYER AND THE WAR EFFORT MUST SUFFER IN ADDITION TO HIMSELF. AS CARBIDE EMPLOYEES, WE HAVE NOTHING TO LOSE AND EVERYTHING TO GAIN FROM A FREE INVESTMENT THAT IS DEFINITELY SOUND. IT IS WISE FOR EACH OF US TO INVEST HEAVILY IN THE PLANT SAFETY PROGRAM.

Clark E. Center

CLARK E. CENTER
Plant Superintendent



The function of the Industrial Relations Division is to supply and maintain a safe, efficient working force, and to administer the facilities necessary in this accomplishment. The divisional function is divided into eight departments handling Employment, Wage and Salary Control, Employees Services, Medical, Safety, Labor Relations, Training, and Insurance. The Industrial Relations Division is expected to set the standard for Plant Safety.

T. E. LANE, Superintendent
Industrial Relations Division



Most accidents which have been experienced in the Process Area have had no connection with process hazards. We feel that we have a well designed plant and that, with the cooperation of the Safety Department in the training of our people in safe practices and safe procedures, we can attain a safety record that will be envied by any plant.

C. N. Rucker

C. N. RUCKER, Superintendent
Process Division

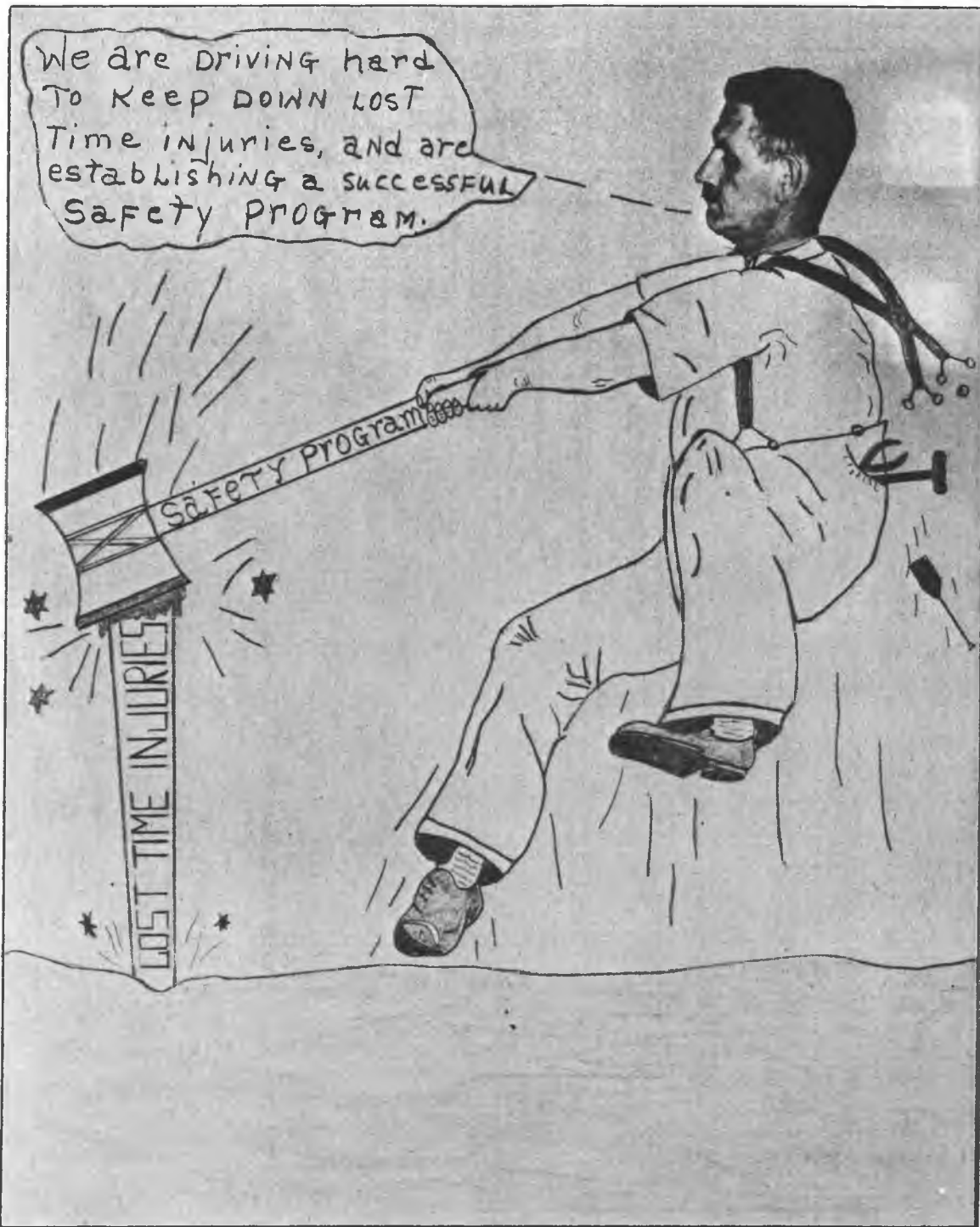

Maintenance Division employees are exposed to numerous injury hazards due to the very nature of their work. This does not mean the Maintenance injury frequency rate need be any higher than other plant divisions since all plant jobs should be carried out in such a manner as to minimize or eliminate the possibility of injuring employees. Injuries have preventable causes.

M Powell
M. POWELL, Superintendent
Maintenance Division

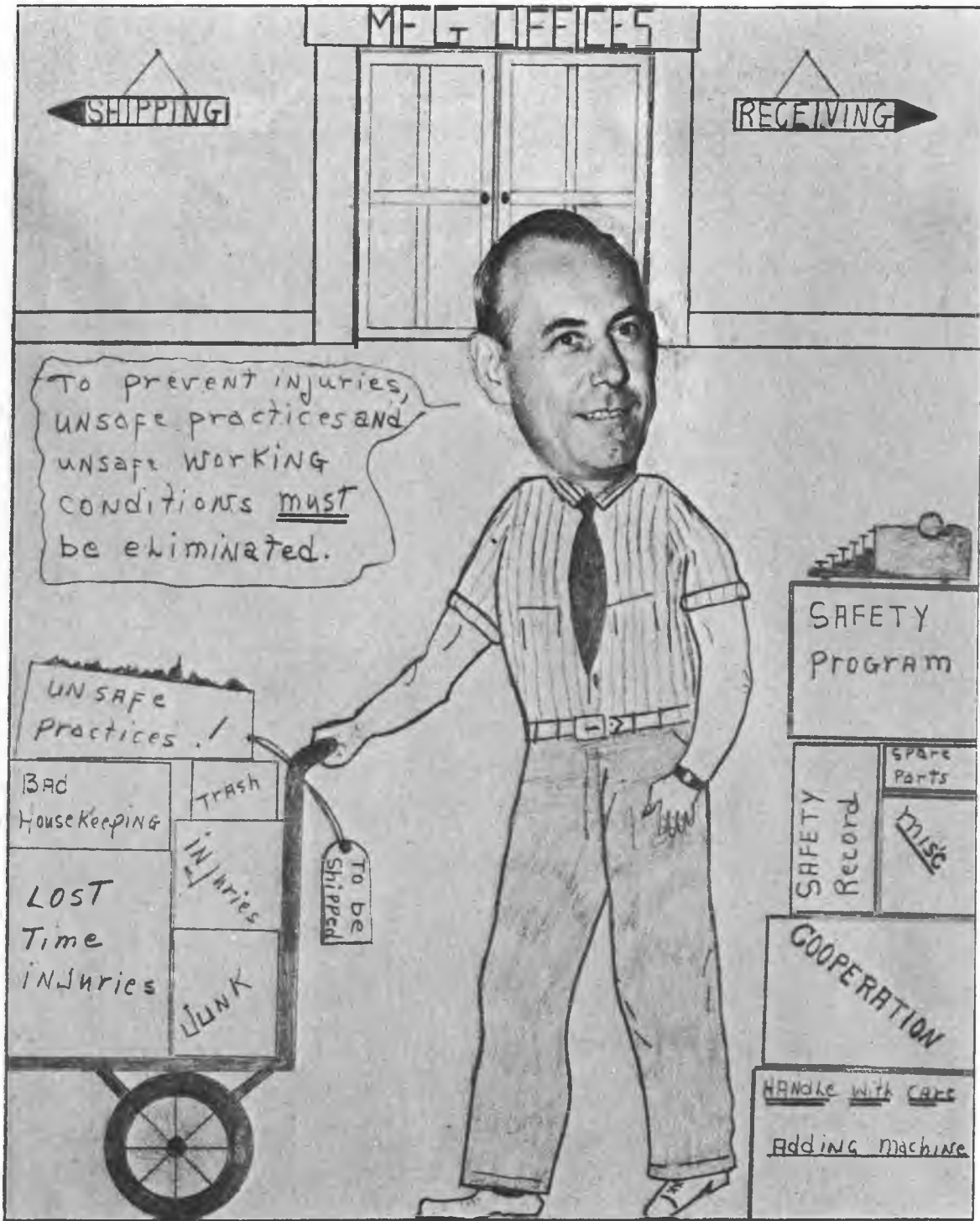

Carelessness, thoughtlessness and fatigue combine to render personal injuries possible on many jobs which, in themselves, may present few injury hazards. These contributing factors to injuries can be minimized by an effective plant safety program. It is good business for both the employee and the employer to contribute to an accident prevention program for their mutual benefit.

G. F. Brown
 G. F. BROWN, Superintendent
 Manufacturing Offices Division

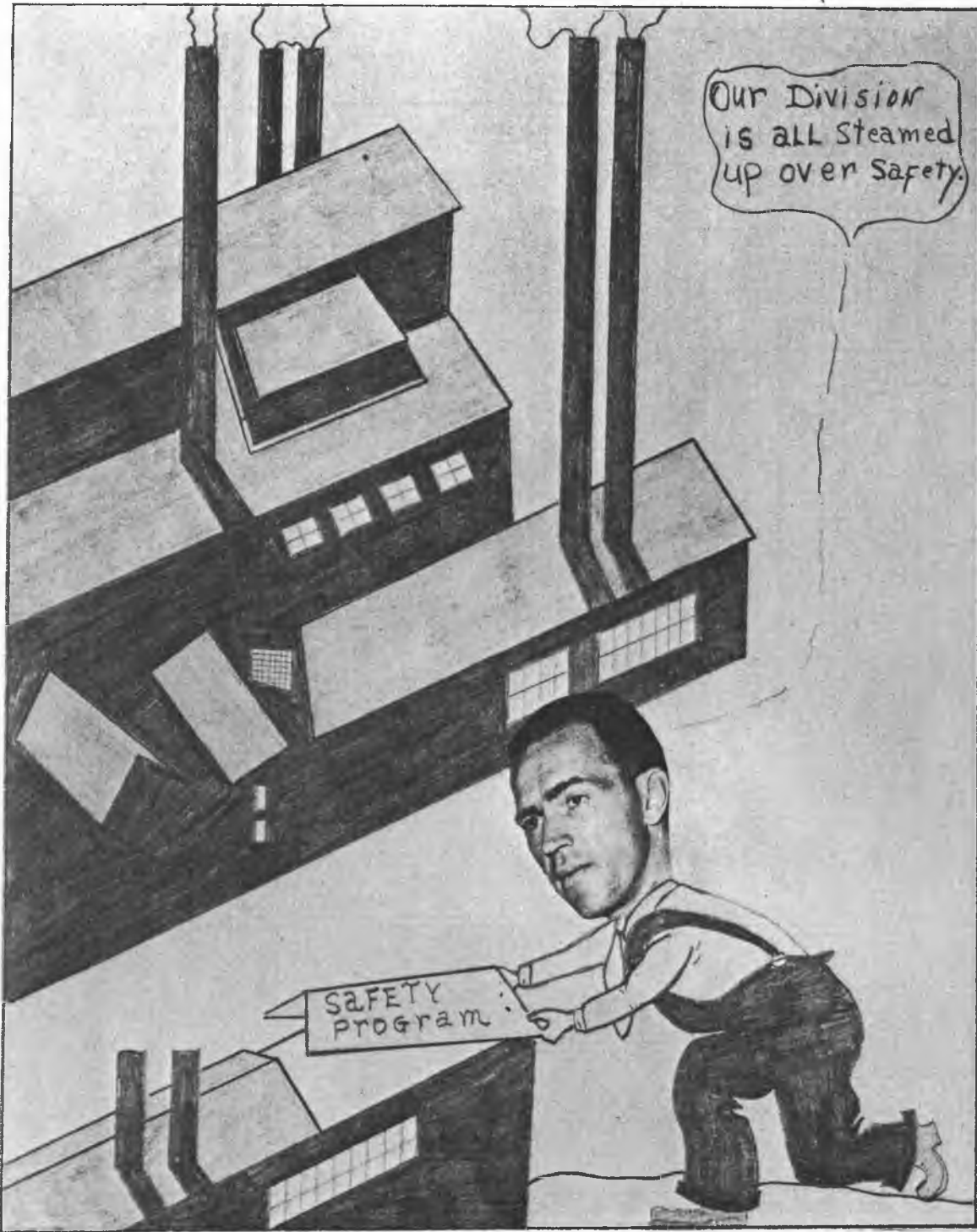

Our business is primarily the generation and distribution of power and other utilities required by the plant. Safety is everybody's business and we can't afford to neglect it. Successful operation requires your safety and that of the equipment we run. Our accident rate so far has been fairly low, but we can't pin medals on ourselves until the rate drops to zero. More power to you.

Otto W. Manz
O. W. MANZ, Superintendent
Utilities Division

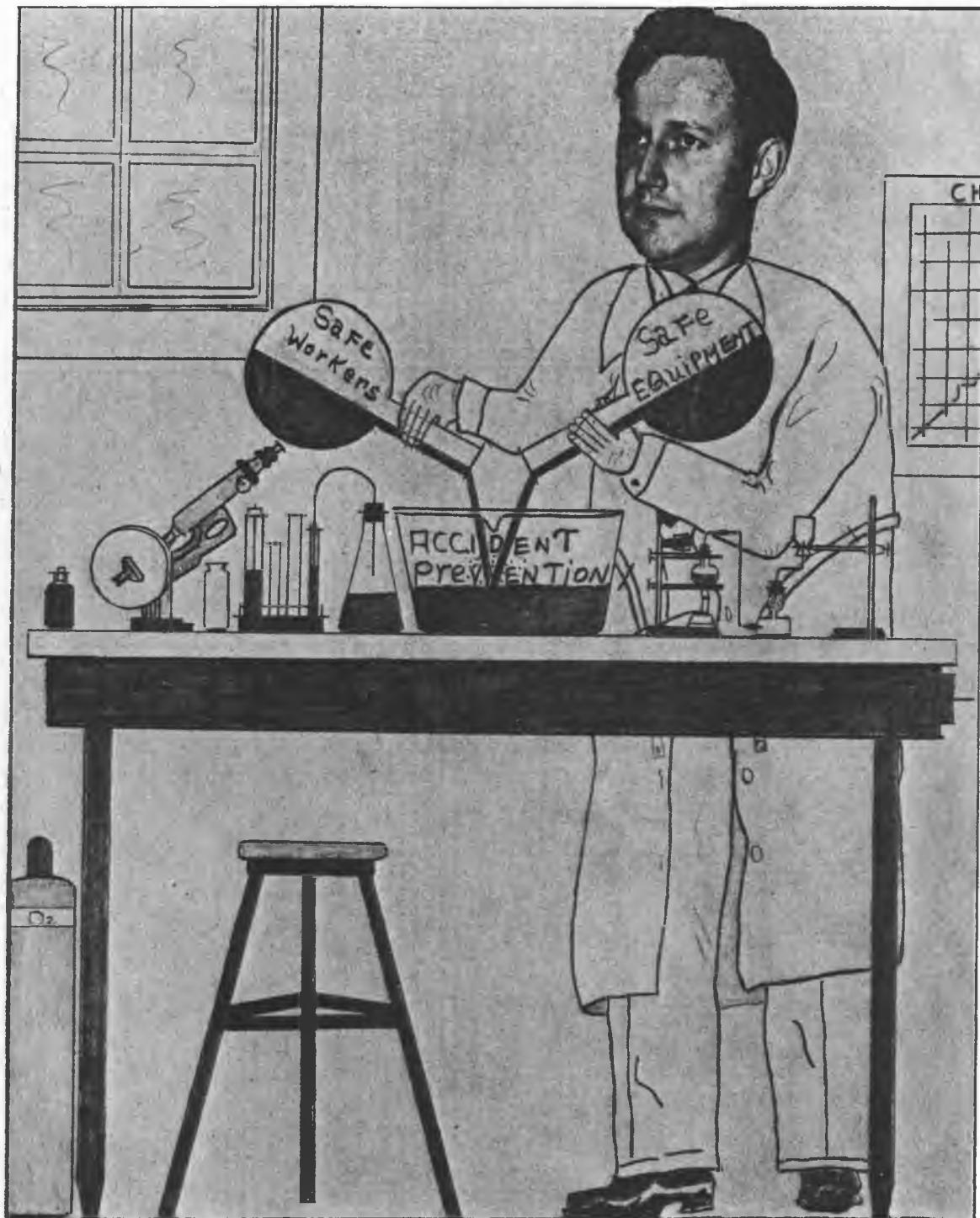

We are proud of the Laboratory safety record to date. Credit must be given to alert supervisors and employees for the low rate of serious accidents on a job which is inherently more dangerous than most. We are enthusiastic about the safety meetings now being held by our employees, and feel that they are making a real contribution to accident prevention in the laboratories through their many valuable suggestions.

D. E. HULL, Superintendent
Laboratory Division



The Security Department is here to safeguard classified information as well as to protect life and property. Security Department employees can aid you in the preparation and safeguarding of classified information while guards and firemen protect life and property. Our services are at your disposal. If we can be of service, call on us.

M. F. McDermott

M. F. McDERMOTT, Superintendent
Plant Protection Division

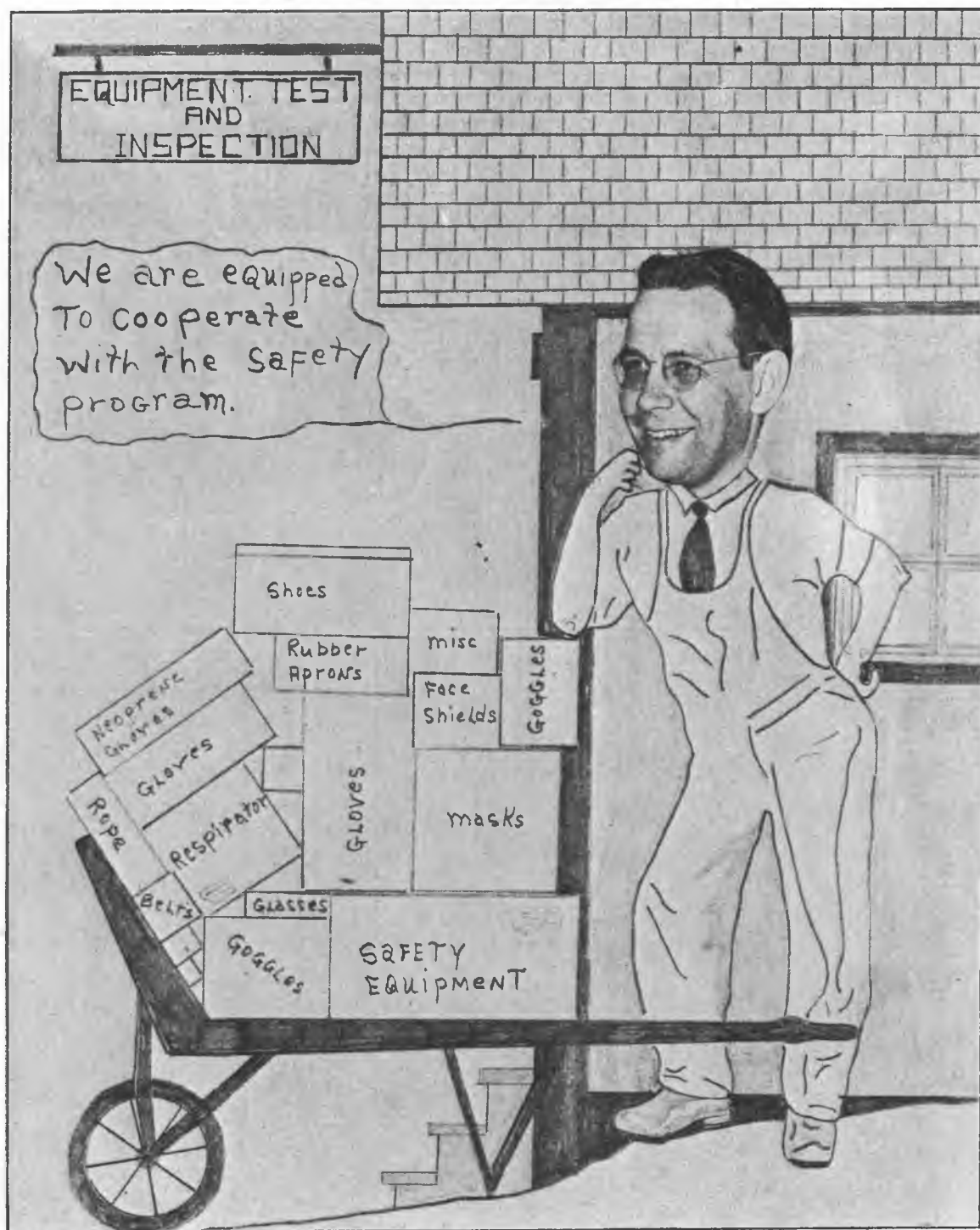

The job of this division is to test and inspect manufacturing machinery and equipment, advising the operator of its condition. Every mechanical device has definite limitations and full knowledge of these will result in a mechanically safe plant. Use our services for your protection. Remember that the lack of a \$5.00 relief valve may result in a mechanical failure with attendant production interruption or personal injury.

A. P. Dunlap

A. P. DUNLAP, Superintendent
Equipment Test and Inspection Division



FRED SMOTHERS

AREA SAFETY ENGINEER FOR MAINTENANCE AND E. T. & I. DEPARTMENTS

Fred got his start in safety as Civil Engineer. He was County Engineer in Reidsville, North Carolina when, through his contacts with the North Carolina Industrial Commission, he became interested in safety work. In 1933 he accepted a position as District Safety Engineer with the Federal Government and thereby decided to devote his life to Safety Engineering. In 1940 he became Chief Safety Engineer with the TVA at Kentucky Dam, Gilbertsville, Kentucky. 1933 subtracted from 1945 adds up to twelve years experience as a Safety Engineer.

Fred's position as Area Engineer for Maintenance and Equipment Test and Inspection is an advisory and technical one which enables him at all times to advise them of the existence of unsafe conditions and the proper methods for protecting personnel.

JOHN HUDSON

AREA SAFETY ENGINEER FOR INDUSTRIAL RELATIONS, LABORATORIES, SECURITY, MANUFACTURING OFFICES, AND PLANT ENGINEERING

John got into safety work by a devious route. Since he finished school at North Carolina State in 1921, he has been a Textile Engineer, center fielder for Columbus in the American Association, half-back for the Washington Redskins and manager of large chain drugstores. In 1933 he decided to stop this playing around so he accepted a job as District Safety Engineer with the Federal Government. He has been working at Safety Engineering ever since. He was Safety Engineer at Fontana Dam for TVA before he came to Carbide to give us the assistance of his broad experience in preventing accidents and protecting the life and health of our people.

JACK CROSS

PROCESS AREA SAFETY ENGINEER

Jack is an old hand at safety work with twenty-six years of Safety Engineering experience behind him. He has held positions with the Traveler's Insurance Company, General Casualty Insurance Company, Sixth Service Command Headquarters in Chicago (Senior Industrial Engineer), and Lloyd's at London (Chief Engineer!). Immediately before coming to Carbide, he was Senior Safety Engineer on the Alcan Highway between Whitehorse, Yukon Territory and Fairbanks, Alaska. Timber wolves were one of his safety problems on that job!

As you can see, Jack has had a vast experience in many types of Safety Engineering and is well qualified to organize the Safety Program for his area and handle safety problems correctly as they arise.



If you have a friend who is operating a power tool, or

JONES • AGRAM

K-25

ISSUE NO. 5

MAY 1, 1945

NEWS AND VIEWS OF SAFETY ON THE JOB AND IN THE AREA HOME.

PUBLISHED BY THE J. A. JONES CONSTRUCTION COMPANY, INC., SAFETY DEPARTMENT.

Pulling Teeth

MARK TWAIN always credited his healthy old age to plenty of strong cigars and stronger whiskey.

Lately I met an old gent who had a different explanation. He'd long since retired from what is generally looked at as a highly risky occupation.

"I'm still alive," he told me, "because I was smart enough to stay that way."

I prodded him a little with a good cigar, and he explained.

"Did you ever hear of the rattlesnake handler who was paid fancy money because of the danger? Well, he just drew the critters' fangs—and kept on drawing the same pay.

"I felt like that rattlesnake feller. I wanted good money for good repair and construction work—not a bonus for a broken neck.

WE AGREE!

The REALLY SMART guy KNOWS that doing his job in the right way with the RIGHT tools means NO ACCIDENTS, just like pulling money out of the air.

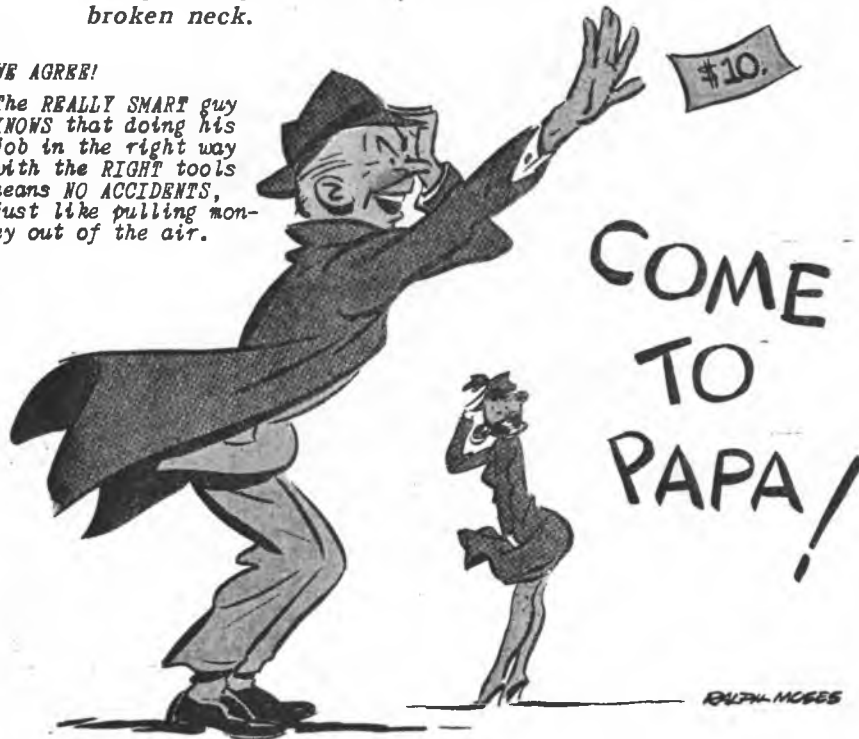

CANDID CAMERAS

We are all familiar with cameras or kodaks, and their construction. We know the image is focused through the lens and that the shutter opens briefly to permit the light to reach the sensitive film inside the camera.

We think of cameras as delicate instruments, and we protect them against rain, excessive sun, heat and breakage. How many of us would set our cameras down, day after day in front of an electric grinder, or under dripping hot welding slag or sparks, or near splashing concrete or acid? They'd get ruined wouldn't they? Sure would!

Fact is, that *YOUR EYES* are *YOUR* cameras. Yep, each eye has a lens, as shutter, iris diaphragm, focus adjustment, and film! And it takes colored moving pictures wherever you may be. *With care*, your eye-cameras will last a life time, and you won't have to spend a cent for film!

The Eyes Have It!



But, we think it's only fair to tell you, that your eyes won't stand the abuse your camera can take, - and you can't buy new ones, or even a new part for one. The lens of an eye is a very thin, transparent membrane or skin which is easily punctured, scratched, burned or infected. Since the eye itself is not solid, but is filled with a clear liquid which helps keep the eye round, a puncture will result in loss of fluid, and removal of the eye may be necessary.

A flake of metal, dust, wood, cement or any other material which may settle on the eyeball can result in infection and loss of vision. No irritation of the eye should be allowed to continue. Waiting "until tomorrow" may be dangerous. NOW, - we'd like to say "see your doctor", (and we will), BUT the worker who's got a brain bigger than a peanut will see to it that a flake of steel or cement won't get NEAR his eyes. Whatever his job, he'll wear a pair of safety-spectacles not over his Adams apple, not over his forehead, but over his eyes. Now we admit dust can blow into your eyes even though you wear specs, and if it happens, - don't let anyone poke in *your* eye with a handkerchief or anything else. That's a job for the doctor, - let him do it.

COULD YOU

G. O. Woody, Badge No. 1-4258 and Glen Vann, Badge No. 1-3402 have been driving the two J. A. Jones mail cars between this project and the Knoxville post office for fourteen months. They have driven more than 100,000 miles without an accident, arrest or complaint against their record.

ETTA-KET (No: nily Post!)

Eating peas with a knife. according to those who know unless you've got a very large This falls into the same category driver to work a "hot" 440

Wearing a hat indoors. It's cute enough so that papa (and it), the hat may be worn indoors hat is always to be worn indoors building where some heavy bald head.

Use of bent forks.

If the bent tine inclines to the left and you're left-handed you can, with skill, steer the bent portion into your gaping vital-trap without any bloodshed. If you're right-handed and have a left-bent fork, you're out-of-order. It's just like using makeshift, bent, mushroomed or broken tools on the job, you're be yours.

Shoe Style-Note

Approved Spring colors: tan. Civilian workers meaning they're safety-toed soft-toed shoes on the job other accessories such as or crimson-tinted casts or have shed the crutches) as you prefer.

Electrician Maintenance F worked his crew nine months accident!

If you have a friend who is operating a power tool, or welding, chipping welds, operating pneumatic tools or hand tools such as a star-drill or a cold chisel, be a friend to him. Tap him on the shoulder and say, "Bill, y' better get your goggles on." And while you're on the subject, - be sure you've got yours on too. (If you don't have a pair, talk to your safety man. He'll know the best style for you to have.)

WE AIN'T FOOLIN'

Attention to details is THE MARK of a real supervisor, sez we. For example, the way Supt. J. M. Holliday keeps all the windows in pick-up 1C-532 SO CLEAN that we tried to toss a butt through a CLOSED window. We always did like a guy who could SEE WHERE HE'S GOING!

F. C. Rainey, Poe Supervisor installed with his crew 2900 pumps and 2900 coolers using chain-hoists, with only 1 lost time injury. WOW!

Phil Hopper, Carpenter Foreman, has been with the Company 25 years and never had a fatality or broken leg in his crews. Has worked 15 man-crew for 16 months with NO LOST TIME ACCIDENTS. Phil has 5 children, - 1 in service. P Phil is ONE reason why the NASTIES CAN'T win.

KERRY DRAKE AND STITCHES

You recall the sad plight of detective Kerry Drake of comic strip fame? How he made a rocket out of an oxygen tank by shooting the valve end off! How the tank shot right through a brick wall? Just for the record, let us assure you that those things REALLY happen.

One case we know about happened at an oil company warehouse. A cylinder of gas sat on a loading platform in the sun. The heat blew out the fusible disk, tipping the cylinder off the platform and when it struck the ground, the valve broke off. Then whooosh! Off went the rocket. It traveled 369 feet, smashing everything in its path! Something to think about when you leave cylinders in the hot sun! Or when you handle cylinders carelessly

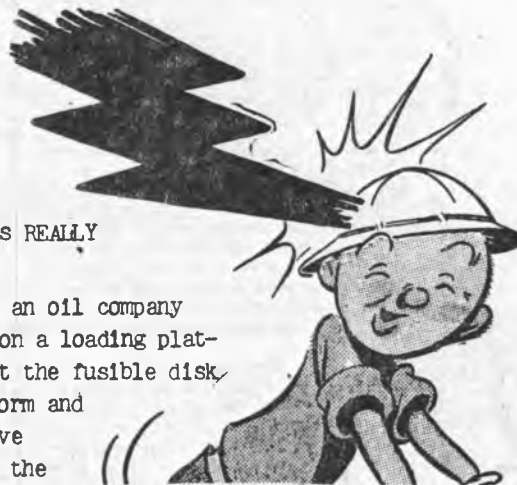

HEY JOE! BE CAREFUL!

2¢

Weather
CLOUDY
(Details on Page 2)

Daily Mirror



3c in Suburbs
5c Elsewhere
in United States

2¢

Vol. 21. No. 216.

NEW YORK, FRIDAY, MARCH 2, 1945

FINAL 6 A. M. ★★ ★★

Walter Winchell In New York

Things I Never Knew 'Til Now

That Uncle Sam lost 10,500 soldiers, sailors and marines in 1944—not by Jap or Nazi bullets, but by accidents in the U. S. . . That when soldiers and sailors actually take heed of their superiors' accident warnings, the accident rate in camps drops 60% . . . This column is dedicated to saving the life of some soldier, sailor, marine or worker in the war effort—and the statistics prove that it probably will . . . Every life lost to this country is one less fighter against Hitler. Your country needs your life—to protect its own . . . This is the breakdown of your chances of living this year:

That 30,000,000 Americans have been injured in home-front accidents since the war started . . . Work accidents last year caused the loss of 900,000 man-years of labor, and more workers were killed OFF the job than on the job—25,000 to 18,000.

That drinking on the part of either the driver or the pedestrian is involved in one out of every five fatal traffic accidents, and that, even in wartime, one or both drivers in fatal accidents violate a law in two out of every three cases.

That about 7,000 persons were drowned in the United States last year . . . Smokers cause nearly a fifth of all fires in the U. S. A. . . Accidents kill one out of three school-age children who die . . . Three out of five fatal traffic accidents occur at night . . . Nearly 2,000 persons were killed in grade crossing accidents last year. (So, Look, Listen and Live!)

That thousands of hunters will be maimed this year—and nearly 1,000 will be killed in hunting accidents unless the hunter is extra careful . . . 17,000 people in farm families were killed by accidents last year—and only mining, construction, transportation and public utilities are more dangerous industries than agriculture . . . About 80,000 hospital beds are occupied today by persons who have suffered accidents. (This is roughly 10% of all beds, and the pity of it is that accident cases usually require the immediate attention of several doctors and nurses, as well as the use of anesthesia apparatus, operating rooms and hospital beds. And this at a time when they're talking about drafting nurses!)

That peanuts, coins, medals, marbles and such simple things can be and are killers. More than 600 children under five years of age are killed every year because small objects like these are so easily sucked into the lungs . . . Falls were the greatest single cause of accidental deaths in 1943, the last year for which figures are available. The number killed by falls in 1943 was 27,400. And 92% of all persons killed by falls are 25 years of age or over; two out of three persons killed by falls are 65 years or older, and more injuries occur on stairs or steps than in any other place in the house.

That Benjamin Franklin was one of the first safety advocates in America. Remember? He said: "Haste makes waste" and "Carelessness does more harm than want of knowledge."

SL
B

By
Raymond
leader, is
purchase
tre, atop
to use
broad
cent
Reco

Tho
nice pr
tre, it w
way for
Which sh
of the thea
beth Bergn
here with
necessitate
day Hartl
the Mrs. C.

"It's a Gift
house March
engagement, a
move to another
Jones, co-direct
Dowling of "T
erie," has bee
rector of a n
repertory cor
Norway" will
formance Sun
Imperial Thea
of the Stage

HOLI

HOLI
big cha
dream
"The
85 sc
P
f
s
R
C
G.
m
rel.

\$15

\$5

That the Chicago fire of 1871, the Johnstown flood of 1889, the Galveston tidal wave of 1900, the San Francisco earthquake of 1906, the sinking of the Titanic in 1912, the Boston night club fire in 1942, and all the other major disasters since 1865 have killed less than 25,000 Americans. (And yet day-by-day accidents killed 94,000 in 1944 alone!)

That accident figures prove the safest people in the U. S. are little girls between the ages of 5 and 14 . . . There is an accidental death in the U. S. every 5½ minutes—and an injury every 3 seconds! . . . Accidents are the fifth cause of deaths in the U. S. . . And cost \$141 per year per family in America.

That the Seaford Nylon Plant of E. I. duPont de Nemours & Company has the best no-injury record in American industry, having gone nearly 17,000,000 man-hours without a single lost time injury to one of its employees. (And at the last report, the record was still running.)

That even if more than 700,000 women drivers were involved in traffic accidents in 1944, there is no conclusive evidence that women are more reckless than men when it comes to driving automobiles . . . A speed violation is a factor in about ¼ of all fatal traffic accidents . . . Approximately 4% of drivers involved in fatal accidents are hit and run drivers! (The rats!)

That communications is the safest industry and mining the most dangerous . . . One person in 14 will have an accident in the United States in 1945, if the 1944 pattern prevails . . . Nearly 10,000 pedestrians are killed in traffic accidents yearly. (And walking is so easy.) . . . The hours between 6 and 8 p. m. are the most dangerous traffic hours in the day for both drivers and pedestrians.

That the passenger death rate for airline travel in 1943 was only 1.4 deaths per 100 million passenger miles. Except for 1939, this is the lowest rate on record and is only one-twentieth of the 1930 rate . . . The passenger death rate per 100 million passenger miles of rail travel in 1943 was only 0.31! . . . Automobiles have killed over ¼ of a million—769,000, to be exact—since the turn of the century.

That the National Safety Council records accident prevention from the bizarre viewpoint now and then, as in its annual roundup of "Odd Accidents," the 1944 edition of which told of three persons who broke their necks during the year in odd accidents like this: Gregory Stingel, 13, of Chicago, broke his neck while pulling off his football jersey; Anne Haldeman, 10, of Doylestown, Pa., snapped a vertebra while skipping rope, and Mrs. Pauline Strother of Indianapolis topped them both by dislocating a vertebra in her neck while vigorously brushing her teeth!

We also liked the story about Henry Butler of Jacksonville, Fla. He was eating breakfast when a buzz saw ripped through the kitchen wall, sliced the breakfast table neatly in two and whirled out the other side of the house. The saw broke loose from a sawmill nearby.

Then there's Stripteaser Betty Rowland of Hollywood, who put so much heart into her work that she bumped one of her swivel-hips against a wall and took off for the hospital, partially paralysed.

JOE
she mu
before s
Ben
Moran on
HOLLYW
Baxter wi
Sonny Du
his orches
lans can
servants
them NINE
(Copyright, 194



AST
3
CRIT
11
GLO
2
GOTH
103
HOLLY
2:20, 4
MUSIC H
1:06
2:30, 4
PALA
1
RIVOLI
3:45
BOX
2:30, 4
2:44 5
STATE
3:55, 7
2:50, 6
STRAND
4:55, 7
1:23, 4
VICTORIA
12:59, 2

ALBEE
3:25, 7
METROP
1:15, 3
PARAMO
3:45, 6:30
11:16, 2:27
STRAND
4:09, 7:18, 10

Where
For
Tick
for
"A
I'
1.
St
(1.

As our allied troops approach and enter Berlin many of us here at home may say, "Whoops! That's that!" and we'll pack up to go back home and resume our old job in the pickle factory, or wherever it was. But **NOT IF WE'RE IN OUR RIGHT MIND WE WON'T!**

Instead we'll remember that millions of our brothers and fathers, -yes and our women folks as well, are still overseas and *will be* for a long time yet until the fighting is over.

We've all got our jobs to do. Let's *do it* until it's really finished!

**AN' WE CAN
PROVE IT,**

The new hutment area, complete with cafeteria and the works, was completed without a single **LOST-TIME ACCIDENT.** Supt. Robert Jones and the one and only "Mr. Mac" McWhirter desire praise on this one!



CONSERVATIVE ESTIMATES

of man-hours on the K312 buildings under the able supervision of **THE A. L. DAVIS** (of Bomber Committee fame) will result in an accident frequency rate 1/16th of the average rate for construction. This is really **HITTING BOTTOM.** If it was any lower, Al, it wouldn't be **POSSIBLE.**

* * * * *

MOTHER: 'BILLY, I WAS HOPING YOU WOULD BE UNSELFISH ENOUGH TO GIVE YOUR LITTLE SISTER THE LARGEST PIECE OF CANDY. WHY, EVEN THAT OLD HEN GIVES ALL THE BEST PIECES OF FOOD TO HER LITTLE CHICKS AND TAKES ONLY A TINY ONE NOW AND THEN FOR HERSELF.'

BILLY: 'SURE, MOTHER. I'D DO THE SAME THING IF IT WAS WORMS.'

Wear good gloves or hand leathers when handling rough or sharp objects.

ETTA-KET (No: nily Post!)

Eating peas with a knife. Not considered good manners, according to those who know. They say it's dangerous too, unless you've got a very large mouth and a very dull knife. This falls into the same group as using a dime-store screw-driver to work a "hot" 440 volt electrical connecting job.

Wearing a hat indoors. If you're a woman, and the hat is cute enough so that papa doesn't sit and sneer at you (or it), the hat may be worn indoors. If you're a man, the hat is always to be worn IF it's a HARD HAT and you're in a building where some heavy object may drop on your smooth, bald head.

Use of bent forks.

If the bent tine inclines to the left and you're left-handed you can, with skill, steer the bent portion into you gaping vital-trap without any bloodshed. If you're right-handed and have a left-bent fork, you're out-of-order. It's just like using



makeshift, bent, mushroomed or broken tools on the job, you're headed for trouble, and it'll ALL be yours.

Shoe Style-Note

Approved Spring colors: Navy;black; Army; tan, Marines; tan. Civilian workers may choose their own colors providing they're safety-toed shoes. Or if you prefer, wear soft-toed shoes on the job and buy (with lost earnings) other accessories such as maple-finished crutches, white or crimson-tinted casts or bandages or later on (when you have shed the crutches) a pair of canes, ANY old color you prefer.

NO FOOLIN'

Electrician Maintenance Foreman, W. F. McKee #11-791 has worked his crew nine months with only one lost-time accident!

struction. We know
opens briefly to
era.

them against rain,
our cameras down,
pping hot welding
I get ruined would-

as a lens, as
takes colored
-cameras will last
you won't have to
film!

only fair to tell
won't stand the
can take, - and
ones, or even a
The lens of an
transparent mem-
is easily punctur-
ed or infected.
f is not solid,
a clear liquid
e eye round, a
t in loss of fluid,
eye may be necessary.

which may settle
No irritation of
orrow" may be dan-
e will), BUT the
it that a flake of
, he'll wear a pair
s forehead, but over
though you wear
eye with a hand-
let him do it.

402 have been driv-
the Knoxville post
0,000 miles without



See some scraps upon the floor
Pick 'em up - and luck galore
Will stay beside you in the shop
And keep your safety right on top.

See some scraps and leave 'em lay
And you may be the one to pay.
Falling into such a trap,
You'll be useless - like the scrap!

-DON MOORE





NEVER
HANDLE MORE THAN
YOU CAN HANDLE SAFELY

TIMELY TOPICS

STONE & WEBSTER ENGINEERING CORPORATION

Handling materials constitute a very large per cent of our activities and is the cause of a large per cent of our accidents. Such a subject should be very **TIMELY** for this week's Five Minute Safety Meeting.

The discussion should include piling and un-piling, lifting and carrying, as well as the use of wheelbarrows, etc. The materials handled here are varied in size, shape and weight; then too some are loose while others may be in boxes, crates, barrels, bags or other packages. Most of it is handled by hand. Just recently two men were carrying a long plank. One man let his end down without warning, causing other man to receive a severe strain. A bag of cement fell from an improperly stacked pile, causing a foot injury. Many more are on record, including back strains, hernias, mashed fingers, toes and hands, all, under the heading of handling materials, and all could have been prevented.

Wearing gloves would eliminate many injuries, and proper instructions on how to lift, how to handle long material, assigning two or more men when heavy objects are handled, using power equipment whenever possible, proper piling and not piled in aisles or passageways. All these and many more precautions enter the picture. Your individual problem has its own solution. Check up on your men -- note the way material is handled --- you'll see some methods you can correct, and which you probably never gave much thought to.

Talk to your men this week on "Handling Materials" and further decrease our accidents.

SPECIAL NOTICE: Salt tablets have been provided at all drinking water barrels. Increased perspiration increases the loss of salt from the body. Salt that is lost must be replaced or fatigue, exhaustion or heat cramps may result. Please tell your men.

FLASH!!!! This War is only half won. Our **MONEY** as well as our labors are definitely needed for complete and final Victory. The purchase of War Bonds is **YOUR INVESTMENT IN AMERICA**. Our quota in the Mighty 7th War Bond Drive has **NOT** been reached. We **CANNOT** and **WILL NOT** Fail. The Time is short. **BUY MORE AND BIGGER BONDS --- NOW.**

Safety Department
Stone & Webster Engineering Corporation

F5d

27 March 1945

SAFETY FILMS AND RECORDS
Available for Loan from the U.S.E.D. Safety Branch

16 MM. FILMS

As the Twig is Bent
Before the Doctor Comes
Danger--Women at Work
Four Thousand Years' Experience
For Safety's Sake
Factory Safety
Guilty
Hell Wouldn't Have Him
Kitchen and Dining Room Safety
No Short Cut
Sentinels of Safety
Singing Wheels
Tomorrow's Too Late
Uncle Jim Tells 'Em
We're on the Spot
Youth Takes to the Highway

35MM. SLIDEFILMS AND RECORDS

Are Your Feet Killing You	How to Instruct
Brains Beat Brawn	If it Happens
Cadet's Chorus (Record)	Keep it Clean
Care and Use of Chain Falls	Learn and Live
Cause and Cure	Learning to Drive
Child Accidents in the Home	Let's Face the Facts
Cold Bug, The	Men of Maintenance
Defensive Driving	Minute Men
Do the Job Right	No Use Skidding
Doctor's Orders	No Time for Goofers
Double Trouble	Nothing Upstairs
Eyes on the Job	Open for Infection
Fall Guy, The	Pilots of the Highway
Fire	Play Safe
Fire Thief, The	Poisonous Snakes of the U. S.
Fire, In Case of	Principles and Interest
Follow the Leader	Production with Safety
Food Keeps You Fit	Right Dress
Giant Hands of Industry	Rules for Tools
Grime Doesn't Pay	Safe all Around
Guard Duty	Safe Electrical Equipment in the
Handling Pressure Cylinders	Home
Handle With Care	Safely Yours
Home Safety	Safely We Work
Hoosier Hotshots (Record)	Safety First
How to Get Ready to Instruct	Safety for Defense

35 MM. SLIDEFILMS AND RECORDS (CONT'D)

Safety for Sale
Safety in the Home
Safety is in Order
Safety on Two Wheels
Stay on the Beam
Stop, Look and Listen
Take Care of Yourself
Traffic Jam Ahead

SAFETY BULLETIN

Little Rhymes FOR Summer Time!



Only careless, thoughtless dummies
Overload cars, boats and tummies!



Private note to wartime workers:
Vacation mishaps make you a shirker!



Never let your son or daughter
Swim in deep, unguarded water.



Take it easy getting sunburned.
You're not apt to have much fun, burned.



If a hep-cat wants to jive he
Fills his shoes with poison ivy!



Prevent a costly conflagration
By dousing campfires on vacation.



Victory's doghouse you should crawl in,
If you come back hurt or all in!



They Give Their Lives For a Cause
ACCIDENT VICTIMS DIE NEEDLESSLY

NEVER
CARRY ACID
UNPROTECTED



THE HARD WAY!

AWKWARD LIFTING
*invites
strains*



STAY CLEAR!



Protect

FEET AND LEGS

**"IT WAS AN ACCIDENT
YES, THEY SELL SAFETY SHOES
NO, I DIDN'T BUY A PAIR
YES, I WISH I HAD
NO, THEY AREN'T EXPENSIVE
YES, IT HURTS
NOW BEAT IT!"**



**WALT
DITZEL**

DON'T BACK UNTIL SIGNALLED



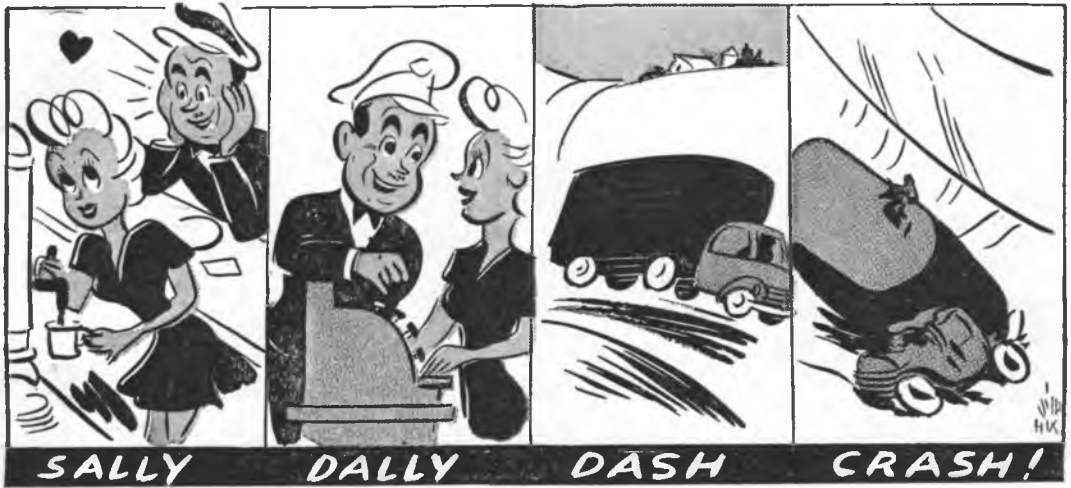

809-T—The National Safety Council, Inc., Chicago.—9-45

Printed in U. S. A.



809—The National Safety Council, Inc., Chicago.—9-45

Printed in U. S. A.

THE *Sab*  **DRIVER**



CORPS OF ENGINEERS
U. S. ARMY

SEPTEMBER

1945

"HITCH HIKERS" AND OTHER CHANCE RIDERS

GIVING rides in your vehicle to persons not authorized by your company to ride with you is a very bad practice, for several reasons:

1. You and the company are responsible for the safety of all passengers. If your vehicle should become involved in an accident and a passenger is injured, you and the company might be sued for damages, whether you were to blame or not.
2. Unauthorized persons in vehicles sometimes are contributing causes of accidents. They talk or otherwise distract the attention of the driver and keep him from concentrating on the hazards of the highway. Driving is a full-time job. A little inattention at a critical time may result in a serious accident.
3. Drivers frequently have been assaulted and robbed by persons who were given a free ride. Many valuable cargoes have been seized in this manner.



When any unknown or unauthorized person asks you for a ride, refuse the request, pleasantly but firmly. Keep your vehicle free of all "hitch hikers."



SAFETY INSTRUCTION CARD No. 496

The SAFE DRIVER

Vol. 16, No. 2

Don Moore, Editor

WAKE UP!

HERE'S an emphatic echo of the facts about driver-asleep accidents you read in the August issue:

The Pennsylvania supreme court, according to *Midwest Motor Transport*, has decided that falling asleep while driving constitutes negligence.

The court's decision said, in part: "In a normal human being sleep does not come without warning. Before sleep there is drowsiness, and before drowsiness there is usually great fatigue or at least a desire to sleep. . . . Therefore, when a driver of a motor vehicle falls asleep while driving, it is legitimate inference that he was negligent either (1) in permitting himself to fall asleep while at such a responsible post of duty, or (2) if he possessed no such will power as would enable him to keep awake under the circumstances, in not ceasing to drive the vehicle. . . ."

Published by the National Safety Council, Inc.,
20 N. Wacker Dr., Chicago 6. Printed in U.S.A.

CURTAINS!

SHAKESPEARE'S mighty pen dripped a lot of blood on the stage of his day, with people getting killed off wholesale by swords, poison and strangulation in some of his plays.

But even Shakespeare's 16-cylinder brain could not dream up a more painful and pitiful scene than the modern real-life tragedy where whole families or several groups of people are killed in one swift, awful accident.

Passing another V-hicle in or near an intersection or near a railway crossing is one way to set the stage for one of those real tragedies.

Insurance Agent: "Here, Mrs. Williams, is a check for \$50,000, the amount of your late husband's insurance."
Mrs. Williams, sighing: "I'd give \$10,000 of it to have him back."

Conductor: "Step lively, please!"
Feminine Voice: "Can't you wait till I get my clothes on?"
All passengers craned their necks to see a woman getting on with a package of laundry.

Hubby, indulgently: "Now do you understand, dear, all this stuff I've been explaining about banking and currency?"
Wifey, wearily: "Yes, but there's still one thing I don't understand."

"What is it?"
"Why we don't do any banking or have any currency."

COMES A REMINDER

COMES September, comes fall, comes rain and earlier darkness,

Comes the time for a special check on whether the windshield wiper is in good working order.

Comes the time to be sure the lights are in focus and the lenses kept clear of spattered mud.

Comes the time to remember that pedestrian deaths usually rise sharply in September because of the longer period of darkness—when the driver has to watch extra carefully for the pedestrian who is not watching extra carefully for himself.

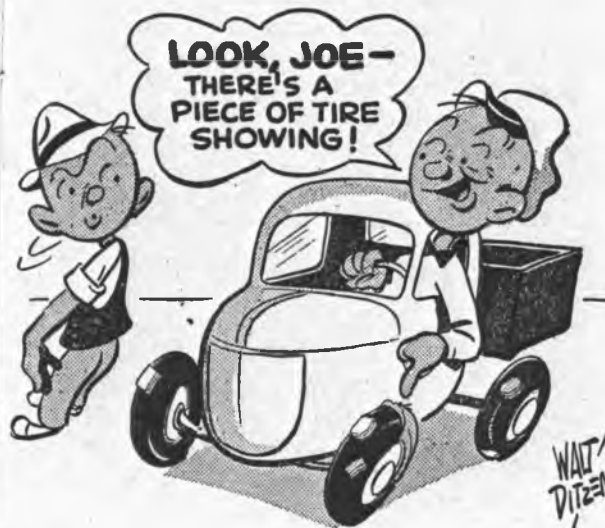

ANT-ICS

THE ANT is supposed to be a model of hard-working efficiency. However, ants have one bad habit in common with human beings.

Watch a bunch of ants streaming back and forth on their jobs and see what happens if you poke a few of them around. The whole gang gets excited and they skitter around in all directions and fall over one another. In short, the wise little ants present a pretty sorry picture of organization in an emergency.

People do the same sort of thing when a traffic accident occurs. In their concentration on the immediate excitement they seem to forget that they may hamper aid to the victims and even cause other accidents with their skittery driving and stopping, pile-up parking and excited milling around on foot.

"I became engaged to the cutest fellow last night."

"You did? What's his name?"

"Oh, you can't ask a man a personal question like that right off."

Think first and you'll last longer.

The nurse bustled into the waiting room and told the professor: "It's a boy!"

The professor looked up vacantly and asked: "Well, what does he want?"



HOGGING

SAID Mrs. Ethel L. Atkins, Grand Rapids, Mich., in a letter to the National Safety Council:

"My daughter was seriously hurt in a traffic accident, because the oncoming car hogged the road. She is now in a hospital with a fractured jaw and several teeth missing. Hogging the road is certainly a menace to lives."

It certainly is. On highways and rural roads *driving on the wrong side of the road* is second only to excessive speed as a cause of fatal traffic accidents.

Sidestep road hogs for self-defense.

SAFETY NEWS



READING both in and between the lines, let's see how safety makes the news:

Barrington, Ill.—A mother robin waited

every day for a certain commuters' train from Chicago—to meet her prospective family! As soon as the train arrived to spend the night in suburban Barrington, Ma Robin would hop onto the nest of eggs, which had been riding the rails on an airbrake cylinder underneath a car!

Somewhere in the Ozarks.—A hermit came out of the woods and saw an automobile for the first time—and the last time. He saw it too late.

Fort Worth, Tex.—A woman phoned the traffic department and asked the date that an automobile accident had occurred at a particular corner in her neighborhood. The police captain, after considerable checking, reported to her that the date she wanted was March 24. Then he asked her reason. The woman hesitatingly confided: "Well, you see, that was the day my cat got out—and I just wanted to know when to expect her kittens."

* * *

It just goes to show you—*When you drive you've got to be prepared for ANYTHING.*

If you should have an accident, you might break a robin's eggs and its heart . . . or kill an un-car-conscious hermit . . . or frighten a cat strolling along the road to motherhood.

REMINDER RHYME

Jim cherished his can't-pass-me rep;
When others tried to pass ol' Jim,
Then he'd speed up and make them step
To squeeze between the hearse and him!

Poor Jim, he never realized —
Until he heard an angel say:
"My dear, you'd really be surprised
How many lives are lost that way!"

Are you careful off the job?

"Did you have the car out last night, son?"
"Yeah, dad, I drove several of the fellows
downtown."
"Well, tell the fellows one of them left his
little lace hanky in the front seat."

Are you proud of your safety record?

Worry will make anybody thin except those
who worry about being fat.

Life is an eternal struggle
to keep one's earning capacity
up to one's yearning capacity.

Old Man, sighing: "I hate
to think about my youth."
Another One: "Why, what
happened?"
First Old Man, sighing
again: "Nothing."

PUBLIC ENEMY!

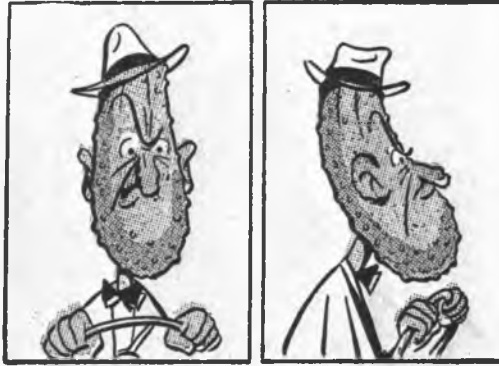

DON'T BE LIKE—

THE PICKLEPUSS, alias Jumbo Dill,
alias "Little Drips" O'Brine.

Has a long sour face, a long sour vocabulary, and a short sour temper. He may be recognized by sound as well as by appearance, for he drives with his side-of-the-mouth mutterings and his belly-aching bellows and his burpish horn blasting more than with his head and his hands.

His dangerous characteristic is that his gas on the mind sometimes takes the violent form of bumper thumping and uncontrolled traffic spasms.



GIVE THE KIDS A BRAKE!

JOE, age 6, was in a hurry to get home from school. He was bothered about twin brother Johnny, who was sick at home. With an important matter like this

on his mind, Joe wasn't watching for the bus when he ran into the street. Johnny got well pretty soon, but Joe, who had worried about him, wasn't around to be glad.

You see, it isn't always just thoughtlessness or recklessness that causes kids to run risks. They have a lot to turn over in those little heads. They have important reasons (important at least to them) for being preoccupied. They have big problems, big dreams, big activities (like the two little girls who were run over last Hallowe'en because they couldn't see well through their masks).

Yes, it's school time again. . . .

There will be another Joe hustling to or from another school, or walking absent-mindedly with another big worry or big wonder or big scheme getting his attention.

Here's a pat on the back for the many drivers who know how to keep distracting thoughts pretty well to the back of their heads and drive so as to give the breaks to a kid with something "important" on his mind.

A pat on the back for every driver who realizes that every school and every kid is a sign that reads—

"CAUTION—MEN AND WOMEN WORKING!"

**"SCHOOL ZONE"
MEANS SLOW ZONE**

IN THESE DAYS of extra-crowded busses, it takes a little extra checking to be sure the doors are not closed and the bus started until all passengers are safely aboard.

Any commercial V-hicle driver who operates thousands of miles a year in modern traffic, with all kinds of weather conditions—*without an accident*—has to really *know* his business.

Don't pass the buck
To Lady Luck.

If all the victims of traffic accidents were laid end to end—they'd still have to make room for the people who refuse to be convinced!

**DO YOU
LIKE TO DIE ?**

LOG OF MY TRIP

Date	Hrs.	Mil'ge	Amount	Gas	Oil	Tax
1						
2						
3						
4						
5						
6						
7						
8						
9						
10						
11						
12						
13						
14						
15						
16						
17						
18						
19						
20						
21						
22						
23						
24						
25						
26						
27						
28						
29						
30						
31						
Total						

**SOME
MISTAKES
ARE
QUICKLY
FORGOTTEN**



**...OTHERS
ARE
NOT!**

**WALT
DITZEN**

THE **Sab**  **DRIVER**



**WALT
DITZEN**

**CORPS OF ENGINEERS
U. S. ARMY**

SEPTEMBER

1945

THE *Safe*
WORKER



CORPS OF ENGINEERS
U. S. ARMY

AUGUST

1945

PUTTING BELT ON A PULLEY

1. It is hazardous to touch or attempt to handle any belt while it is in motion.
2. Stop the machinery and lock the power off with your individual lock. If two or more men are working on the belt, each should place his own lock on the power switch.
3. Force the belt on the pulley as far as possible by hand; then tie it as shown in the illustration, using string, cord, or rope light enough to break if the pulley swings around too far. Turn the pulley over by hand, if possible; if not, remove the lock and, after making sure that everyone is in the clear, "inch" along the pulley with power.
4. If the belt does not ride onto the pulley in a proper manner, call the millwright department to make the necessary alignment.
5. When necessary to use a ladder to reach the pulley, be sure that the pulley is not in motion and that the power switch is locked. Have a helper hold the ladder while you are on it. Remove the ladder before power is applied.

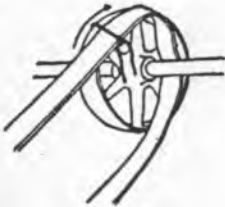

SAFETY INSTRUCTION CARD

No. 8

The SAFE WORKER

Vol. 18, No. 8



Don Moore, Editor

IT'S PRACTICAL

IDEALISM, in the opinion of many practical people, is not such an ideal thing. At least, you've noticed how a man who gets himself in the public eye with so-called idealistic policies or ideas in business, politics or philosophy can find that he is also in the public's hair pretty noticeably, and that one side of the public's mouth is calling him "idealist" with the same tone which would ordinarily be used to call a man, shall we say, a "jerk."

Well, safety, as a way of life, is a social ideal. And it's worth high effort, make no mistake about that.

But, if you're one of the people who prefer more solid, more realistic foundation for everything, then don't overlook this clear and simple FACT:

Keeping alive and sound and helping others to do the same is the **MOST PRACTICAL** thing anyone can do!

Published by the National Safety Council, Inc.,
20 N. Wacker Dr., Chicago 8. Printed in U.S.A.

DON'T GET SMUG

THE Maginot Line did not keep France from being over-run by the Nazis. . . .

The West Wall, the once-mighty Luft-waffe and the super-race doctrine did not save Germany. . . .

A fortified stolen island empire, stop-at-nothing planning for conquest and fanatical fatalism have failed to spare Japan and the Japs from doom. . . .

Worlds of water on both sides, and even a desire to live and let live plus a record of doing same failed twice to seal off America from world war. . . .

Smug dependence on safeguards and safety records is FALSE SECURITY. As in a war, avoiding and preventing accidents demands CONTINUOUS INDIVIDUAL AWARENESS AND EFFORT.

Most every man wishes he were as smart as he thinks his wife thinks he is.

Remove chips from a metal lathe with a brush, stick or hook, not with bare hands.

A loan company is a place where you can borrow all the money you need, if you can prove that you don't need it.

WHAT WAS WRONG?

A PIPEFITTER in a refinery was attempting to break a 1½ inch union above his head with a 24-inch wrench. The union would not break and the man placed a piece of pipe on the handle of the wrench to lengthen the leverage, and he pulled down on the pipe. The wrench handle broke, causing the end of the pipe to strike him on the head.

What should the man have done to avoid this accident? See page 14.

Don't be too quick to accuse others and excuse yourself of carelessness.

If the people who dictate women's fashions are not careful, they'll work themselves right out of a job.

NEVER WEAR LOOSE CLOTHING "AROUND" MOVING MACHINERY!

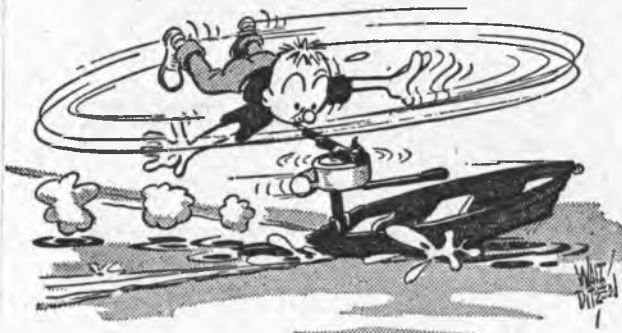

HERE'S TO—

LAST YEAR marked the 100th anniversary of an important step in industrial accident prevention. In 1844 a law was enacted in England providing for the fencing in of mill gears and shafts. As far as is known, this was the first official measure taken to safeguard the lives and welfare of industrial workers.

Well, they say the first 100 years are the hardest. And safety really has come a long way, both in the matter of safeguards and in workers' attitudes.

Here's to the next 100 years!

Marge: "I don't know just how to get rid of him."

Midge: "Are you afraid if you drop him, he'll tell lies about you?"

Marge: "Well, no, I don't mind the lies. But if he ever tells the truth—!"

A machine guard broken or not operating properly should be reported immediately.

The secret of success in any organization consists of putting everybody on a committee and getting one guy to do all the work.

The cost of living is high—but the cost of risking life is much higher!

CAREFUL, POP!

MANY MILLIONS of words roll off our tongues (and out of our typewriters) about safety. And certainly the words are not wasted in such a cause. But it takes just a few words straight from the heart of a kid to pop or mom to do a real man-sized job of selling safety.



It just goes to show us that we need to think oftener and more continuously about the simple, sentimental good REASONS for being careful and alert, reasons that mean real living, such as—so we can go fishing with the kid.

A WHALE OF A STORY



MR. RIPLEY told us recently in the newspapers that the whale "has a bigger, better and more convoluted brain than man's." And he quoted Prof. Adam Sedgwick: "If the whale had a thumb with which to grasp and hold a tool, it would have been master of the world."

Strong words, those! So we immediately sent our Roving Reporter to the Panama Canal to ask a question of average whales as they traveled their Main Street from ocean to ocean. The question asked these misunderstood mental monstrosities was: "What about accidents and safety?"

The first sea-going mammal-on-the-street was of the species known as Sulphur-bottom Whales. He declared: "I declare, the way you so-called higher animals butcher yourselves and others in accidents is enough to make any safety-minded, life-loving whale blow his top." And he did just that—spouting steam and cuss words.

Number two was a Porpoise with a purpose—very business-like. "Sorry, Bud," he said. "I haven't time to talk to you now. I'm busy devising a protective guard for the sharp end of a whale harpoon."

The third swimmer-by was a Grampus Whale, a bald-headed, wrinkled old-timer. He clicked his uppers and spoke: "He's asking me do I believe in safety! Me—who saved a human guy named Jonah from drowning and taught the world one of its first safety lessons. Me—who has lived and worked millions—do you hear me? —*millions* of accident-free whale-hours. You people!"

And then came a fellow known as the Right Whale. He said: "We get a whale

of a kick out of living and letting live. The only reason we sometimes cut loose and bite a ship in two is that we're frustrated. Think of it, man—if I had a thumb to grasp and hold a tool with, I could be master of the world. And, of course, it follows logically that my super-convoluted brain would see to it that I would always *use the proper tool and use it the safe way*. If you'll excuse me now, I gotta blow."

As he returned to his job of making whale oil, perfume and whalebone for old-fashioned corsets, he flipped our reporter a copy of a recent issue of "*The Safe Worker*." It was somewhat soggy, but undoubtedly it would have been well thumbed, if the whale had had a thumb.

"My father and mother were first cousins," the new pupil explained to his teacher. "I guess that's why I look so much alike."

You'll *LAST* longer if you think *FIRST*.

Johnson had just moved into a hotel apartment. He wanted to get himself a radio, so he called up the clerk and inquired: "Do you have A.C. or D.C. current?"

"Just a moment," replied the clerk, and then, after a short pause, returned to the phone with the report, "I'm sorry, but neither of them is registered with us."



RATTY

SOME of the pranks that might go off all right at home and get a laugh even from the goat just don't work out that way at a working place. For instance:

A girl worker was returning to her machine from the rest room. A male worker ran toward her swinging a big rat that had just been killed. The girl, frantic with fright, ran back toward the rest room, stumbled on the stairs going up to the room, fell hard and sustained severe bruises on her ankle, thigh and shoulder.

Not so funny.

A job's just a job, maybe—but it may not be if you have an accident!

JUST A HABIT!



WE KNOW a guy who seldom misses a cigarette butt—on the sidewalk, in a corridor or even in a remote corner of a building. No, he doesn't shoot snipes. He steps on them, whether they appear to be still burning or not.

It looks a little peculiar sometimes, a little kiddish, to see him kick at a stub suddenly or zigzag out of his way to stomp on one. But if you ask him why he does it, he'll say, "Oh, it's just a habit. Maybe it'll prevent a fire sometime."

Just a habit. . . .

Maybe it'll prevent a fire. . . .

Two simple lines—but they say a lot between them. We'll bet our friend's simple habit, which may look silly to some, HAS prevented a fire or two—and that's *not* silly, is it?

No, we're not hinting that everybody ought to be a cigarette butt stepper-on-er. But maybe some worker will get the spark of an idea to be a *more consistent* safe housekeeper at work:

To keep scraps and waste picked up and put in the proper safe places. . . . To keep tools and portable equipment out of aisles and other dangerous spots, especially overhead. . . . To clean up oil spots. . . . To pile material securely in proper regular places. . . . To report promptly any blocked exit or fire fighting equipment. . . . To help keep stairs and landings clear. . . . To pick up little things like nails, bolts, milk bottles.

It's just a habit. . . . BUT—

DRINK LOTSA WATER

ANSWER to question on page 5: The worker should have used a larger wrench instead of the makeshift handle extension. And he should not have pulled the wrench in line with his head.

Be sure to protect *others* as well as yourself when doing electric arc welding. Keep the portable shields in place. If workers nearby are unprotected by the shield, warn them to wear goggles.

When through using a pneumatic gun, close the air valve and clear the hose of air before putting the gun back on the truck.

Hearty breakfast—steady hand . . .
Don't depend on coffee-and.

SAFETY IS NOTHING BUT COMMON SENSE

RECORD OF MY TIME

Date	Hrs.		Rate	Amount
1				
2				
3				
4				
5				
6				
7				
8				
9				
10				
11				
12				
13				
14				
15				
16				
17				
18				
19				
20				
21				
22				
23				
24				
25				
26				
27				
28				
29				
30				
31				
Total				

WHAT IF

!! THE NEXT GUY
MIGHT BE
BAREFOOTED !!



KEEP FLOORS CLEAN!

MANHATTAN DISTRICT HISTORY

SAFETY PROGRAM

APPENDIX "G"

**National Safety Council, Consolidated Report,
"A Community Safety Program for Clinton Engi-
neer Works, Oak Ridge, Tennessee".**

This appendix is bound separately.

MANHATTAN DISTRICT HISTORY

SAFETY PROGRAM

APPENDIX "H"

FILE REFERENCES

<u>No.</u>	<u>Description</u>	<u>Location</u>
1	District Circular Letters (Safety)	Correspondence and Library Section, District Office.
2	Reports of Boards of Investigation, Fatal Accidents.	District Safety Branch, File 5.
3	Letter to Tennessee Department of Labor, 8 December 1943	District Office Files, ORBO-729.3-Safety.
4	Area Safety Files.	District Safety Branch, File 3.
5	Reports, W.D., AGO Forms 501 and 502, and Form ED 404.	District Safety Branch, Files 4 & 5.
6	Standard Procedure for Examining, Testing, and Selective Training of Motor Vehicle Drivers (and Addendum thereto), Army Service Forces, Corps of Engineers.	
7	National Safety Council, <u>A Community Safety Program</u> , dated October 1943 for Clinton Engineer Works and November 1943 for Hanford Engineer Works, with two Supplementary Reports at each project made in the Spring and the Fall of 1944.	District Safety Branch, File 3.
8	Memo from Lt. W. G. Johnson to Mr. J. R. Maddy, 23 August 1945.	District Safety Branch, File 5, "Special Statistical Studies".

~~SECRET~~

INDEX

(Abbreviation App. = Appendix)

Accomplishments, 5.1
 Occupational, 5.1
 Quality, 5.8
 Traffic, 5.7
Alabama Area, App. B1&5
American Industrial Transit, 2.10,
 4.3, App. B1&6
American Legion, 4.3
American Red Cross, 3.6, 6.2, 6.9
American Standards Assn., 2.5, 5.2,
 App. C5
Areas, 6.4, App. B1&5, H4
Area Engineers, 1.3 (Also see
 Resident Safety Engineers)
Army Service Forces, 2.11
Assistance, 6.9
Automotive Transportation Officer,
 6.3

Bamer, L. G., 6.8
Bartnett, R. T., 6.8
Beverly Area, App. B1&5
Boston Area, 6.5, App. B1&5
Brown, James M., 6.8

California Area, 6.5, App. B1&5
Carbide and Carbon Chemicals Corp.,
 2.10, 6.8, App. B1&6, C8&11, F5
Chemical Warfare Service, 5.5
Chicago Area, App. B1&5
Child Activities Group, 3.8, App.
 E9
Chrysler Corp., App. B1
Circular Letters, 1.4, 1.5, 2.11,
 App. C1, H1
Clinton Engineer Works, 2.8--2.10,
 3.1, 5.7, 6.1-6.5, App. A3, B1,
 B1,5&6, E6,7&9, G1, H7
Clinton Homebuilders, App. B1
Clinton Laboratories, App. B1&6,
 C7
Codes, 1.4, 2.5, App. C3&5
Codes, traffic, 3.4, App. C12
Colorado Area, App. B1&5
Columbia Area, App. B1&5
Columbia University, App. B1
Committee, Saf. Advisory, 6.2, 6.3

Community safety, 3.3, App. G
Conferences, 3.2
Congestion, 3.1
Consolidated Mining and Smelting,
 App. B1
Construction, 2.3, 5.1, 5.3, 5.4,
 App. A2-5, B1,3&6
Contests, 3.5, 4.3, App. E5
Contractors, 1.2, 1.3, 2.6, App. B1
Corps of Engineers, 5.4, App. C3
 (Also see Office, Chief of Eng'rs)
Cost of program, 6.8

Decatur Area, App. B1&5, C7
Design, 2.3, 3.6
Detroit Area, App. B1&5
District Safety Engineer, 6.4, 6.6
Driver's Permits, 3.3, App. D3,
 E3&4, H6
Driver training, 2.10, 3.5, App. E2
DuPont, E.I., deMouours & Co., 2.4,
 6.8, App. B1&6

Education (see Schools and Training)
Efficiency, 1.1, 2.5
Electromagnetic plant, 2.3, 2.8
 (Also see Tennessee-Eastman Corp.)
Enforcement, 2.6, 3.3
Engineers, safety, 2.2, 6.4-6.8,
 App. C16

Fatality rate, 5.2 (Also see Rates)
Faust, J. T., 6.7
Fercleve Corp., App. B1&6, C9
Ferguson, H.K., Co., App. B1&6
Films, 2.10, App. F6
Fires, 1.2
First aid, 2.4, 4.2, 6.9
Ford, Bacon & Davis, Inc., App.
 B1&6
Frequency rate, 5.2 (Also see
 Rates)
Fuller, George A., Co., App. B1

Gas Diffusion Plant, 2.5, 2.8 (Also
 see Carbide & Carbon Chem. Corp.)
Government employees, 5.1, 5.3,
 App. A2-5, B1,3,&4, F7

~~SECRET~~

~~SECRET~~
INDEX

(Abbreviation App. = Appendix)

Hanford Engineer Works, 2.10, 3.1,
6.1, 6.5, App. A4, B1&5, E8, H7
Hensley, J. W., 6.8
Home Safety, 3.6, App. G
Hooker Electrochemical, App. B1
Hostetter, G.M., 6.7
Houdaille-Hershey Corp., App. B1

Injury, disabling, 5.3 (Also see
Rates)
Inspections, 2.1, 2.2, 3.5, App.
C4, D2
Interior, Department of, 2.9, 6.10
International Association of Chiefs
of Police, 3.4, 6.10
Introductory material, 1.1
 General, 1.1
 Policies, 1.2, 1.3
 Purpose of program, 1.1
 Regulations, safety, 1.4
 Scope of program, 1.2
 Security, effect of, 1.5
Investigation, 1.4, 3.4, App. D1&4
G
Iowa Area, App. B1, B5

Johnson, John A., & Sons, Inc.,
App. B1 (Note b)
Johnson, Wm. G., 6.6, App. C15
Jones, J.A., Construction Co., 2.5,
4.3, 6.8, App. B1&6, F5
Junior Chamber of Commerce, 4.3

Kellex Corp., App. B1
Kelly, D.W., 6.8

Labor, State Departments of, 1.5
Labor, U.S. Department of, 2.9,
5.4, 5.5, 6.10
Linde Air Products, App. B1

Maddy, J.R., 6.6, App. C15
Madison Square Area, App. B1&5
Marsden, W. H., 6.7
Materials and equipment, 1.5, 4.1
 Equipment, 4.1
 Literature, 4.1

Medical Branch, 1.2, 2.7
Medical care, 4.2
Meetings, 4.2, App. C14
Midwest Piping & Supply Co., App.
 B1 (Note a)
Mills, Harvey, 6.6
Milwaukee Area, App. B1&5
Monsanto Chemical Co., 2.7
Morgantown Area, App. B1&5
Murray Hill Area, App. B1&5

Nat'l Board, Fire Underwriters, 2.5
Nat'l Fire Protection Assn., 2.5
Nat'l Safety Council, 2.5, 2.9, 3.4,
3.7, 4.3, 5.4, 5.5, 6.9, App. C5&13,
F2&8-10, G, H7
Newspapers, 2.9, App. F4
New York Area, App. B1&5
Nunn, W. F., 6.8

Oak Ridge (See Clinton Engr. Wks.)
Occupational safety, 2.1
 Construction, 2.3
 General, 2.1
 Operations, 2.5
 Procedures, general, 2.1
 Reporting, accident, 2.10
 Training, safety, 2.8
O'Driscoll and Grove, Inc., App. B1
Off-the-Job safety, 3.8
Office, Chief of Engineers, 1.5, 3.3,
4.1, 4.2, 6.9
Officers-In-Charge, 1.3, 6.3
Operations, 2.5, 5.1, 5.3, 5.5, App.
 A2-5, B1&3-6
Orders and Regulations, C. of E.,
1.3, 2.11, App. C2
Ordnance Department, 5.5, App. B1
Organization, 6.1, App. A6-9
 Assistance, 6.7⁹
 Contractors, 6.7
 Cost, 6.8
 Development, 6.1
 Formation, 6.1
 Personnel, 6.5
 Present organization, 6.3

INDEX

(Abbreviation App. = Appendix)

- Patrols, school safety, 3.5
- Personnel, 6.5, 6.8
- Pile plants, 2.4, 2.8 (Also see DuPont, Clinton Laboratories, and Hanford Engineer Works)
- Playgrounds, 3.7
- Police, traffic, 3.3
- Policy, 1.2, 1.3
- Posters, 2.10, App. F8
- Procedures, 2.4, 2.5
 - Contractors, 2.6, App. C6-10
- Public Safety, 3.1
 - Community, 3.3
 - Driver's Permits, 3.3
 - Enforcement, 3.3
 - General, 3.1
 - Home, 3.6
 - Inspection, vehicle, 3.5
 - Nat'l Safety Council Survey, 3.7
 - Off-the-job, 3.8
 - Recreation, 3.7
 - School, 3.7
 - Shows, 3.7
 - Traffic, 3.1
 - Traffic Engineering, 3.1
- Purpose of program, 1.1
- Radioactive hazards, 2.8
- Rasmussen, W. S., 6.7
- Rates, accident,
 - Occupational, 5.1-5.7, App. A2-5, B3-6
 - Traffic, 5.7
- Recreation safety, 3.7
- Reeder, E. J., 6.7
- Research laboratories, 2.7
- Regulations, safety, 1.4, App. C3
- Reporting, accident, 1.4, 2.10, 3.4, App. D1&4
- Resident safety engineers, 1.3, 2.2, 6.4, 6.7, App. C16
- Richland (See Hanford Engr. Works)
- Ridge, M. E., 6.7
- Roane-Anderson Co., 2.10, 6.2, 6.8, App. B1&6, C10&11
- Rochester Area, App. B1&5
- Rule books, 2.6, 2.9, App. C7&9
- St. Louis Area, App. B1&5
- Savings, 5.5, 5.6, App. B4
- School safety, 3.5, App. G
- Scope of program, 1.1, 1.2
- Security, effect of, 1.5
- Severity rate, 5.2, (Also see Rates)
- Size of program, 5.1, 6.6, 6.8
- Shows, community safety, 3.8, App. E7&8
- Stone and Webster Engineering Co., 6.8, App. B1, B6
- Tennessee-Eastman Corp., 6.8, App. B1&6, C6&11
- Tests, driver, 3.3, App. D3, E3&4 H6
- Thermal diffusion plant, 2.8 (Also see Ferclove Corp.)
- Tonawanda Area, App. B1&5
- Traffic safety, 3.1, App. G
 - Driver's Permits, 3.3
 - Enforcement, 3.3
 - Inspection, Gov't Vehicles, 3.5
 - Traffic engineering, 3.1
- Trail Area, App. B1&5
- Training, safety, 2.8
- Trends, injury rates, 5.3
- University of California, App. B1
- University of Chicago, 2.7, App. B1
- U. S. Vanadium Corp., App. B1
- Wabash River Area, App. B1&5
- Wilmington Area, App. B1&5

~~SECRET~~
MANHATTAN DISTRICT HISTORY

BOOK I - GENERAL

VOLUME 11 - SAFETY PROGRAM

SUPPLEMENT

TABLE OF CONTENTS

<u>Par. No.</u>		<u>Page No.</u>
FOREWORD		
SUPPLEMENT TO SECTION 1 - INTRODUCTION		
S1-1	General	"S"1.1
S1-3	Scope of the Program	"S"1.1
S1-4	General Policy	"S"1.2
S1-6	Safety Regulations	"S"1.2
S1-7	Effect of Security on Safety	"S"1.2
SUPPLEMENT TO SECTION 2 - OCCUPATIONAL SAFETY PROGRAM		
S2-1	General	"S"2.1
S2-2	General Procedures	"S"2.1
	c. Inspection Reports of Areas	"S"2.2
S2-3	Construction Safety	"S"2.2
S2-5	Safety Training	"S"2.2
SUPPLEMENT TO SECTION 3 - PUBLIC SAFETY PROGRAM		
S3-2	Traffic Safety	"S"3.1
	a. Traffic Engineering	"S"3.1
	(1) Traffic Counts	"S"3.1
S3-3	Community Safety	"S"3.2
	a. School Safety	"S"3.2
	b. Home Safety	"S"3.3
SUPPLEMENT TO SECTION 4 - OTHER SAFETY ACTIVITIES		
S4-1	Safety Materials and Equipment	"S"4.1
	a. Literature	"S"4.1
	b. Equipment	"S"4.1
S4-2	Periodic Meetings of Safety Personnel	"S"4.1
	a. Local Meetings	"S"4.1
	b. National Conferences	"S"4.1
S4-3	Medical Care	"S"4.2
S4-4	Contests	"S"4.2

~~SECRET~~
~~SECRET~~

Par. No.

Page No.

SUPPLEMENT TO SECTION 5 - ACCOMPLISHMENTS

S5-1	Occupational Safety Record	"S"5.1
	a. Magnitude of the District Safety Program	"S"5.1
	b. Methods of Comparison	"S"5.1
	c. Units of Comparison	"S"5.1
	d. Trend of District Injury Rates	"S"5.2
	e. Comparison of District Construction Injury Rates	"S"5.3
	f. Comparison of District Operations Injury Rates	"S"5.4
	g. Savings Effected by the District Safety Program	"S"5.4
	h. Insurance Savings	"S"5.5
	i. Detailed District Safety Records	"S"5.5
S5-2	Traffic Safety Record	"S"5.5
S5-3	Quality of Accomplishment	"S"5.5

SUPPLEMENT TO SECTION 6 - ORGANIZATION

S6-3	Present Organization and Responsibilities	"S"6.1
	e. Clinton Engineer Works	"S"6.1
	f. Hanford Engineer Works	"S"6.2
S6-4	Personnel	"S"6.3
S6-6	Cost of the Safety Program	"S"6.3

SECTION 7 - FIRE PREVENTION AND PROTECTION

7-1	General	7.1
	a. Organization	7.1
	b. Scope	7.1
	c. Problem	7.1
	d. Development of Program	7.2
	(1) Construction Contractors	7.2
	(2) Cost-plus-fixed-fee Operations Contractors	7.2
	(3) Supply Contractors	7.2

~~SECRET~~

~~CONFIDENTIAL~~

MANHATTAN DISTRICT HISTORY

BOOK I - GENERAL

VOLUME 11 - SAFETY PROGRAM

SUPPLEMENT TO SECTION 1 - INTRODUCTION

SI-1. General. - This supplements the history of the Manhattan District Safety Program and provides an account of the development, refinements and advances which have been made under that program during the period from 1 July 1945 to 31 December 1946. During this period, construction exposure decreased and production activities were continued, however, the suitability of the basic program to meet the changes in exposure from one phase of the work to another, and as a peace time as well as a wartime measure, has been well demonstrated.

SI-2. Purpose of Program. - The purpose of the program is still fundamentally the same as in the basic volume.

SI-3. Scope of the Program. - The Manhattan District Safety Program has been expanded to include more responsibility for fire prevention and protection in addition to safety, and, except for Los Alamos and its satellite sub-projects, to embrace all phases of the work of the District. While the scope of the Safety Program was formerly limited to Manhattan District construction and operations contractors receiving reimbursement for payroll costs from the Government, it has now been expanded to include the District's supply and service contractors. Fire prevention and protection responsibilities have been included also for Government-owned contractor-operated plants supplying District material and for plants engaged in processing District material. Responsibility, moral

at least, has been accepted under the program for the Safety of employees of contractors who are supplying unusual or especially hazardous materials.

SI-4. General Policy. - There has been little change in this respect over that contained in the basic volume with the exception of a general policy for decentralization and minor changes in reorganization of the Branch. This has permitted a gradual absorption, or inclusion of District satellite projects by, or with, associated divisions, or larger areas, employing a resident safety engineer. A more satisfactory means of providing constant safety engineering service exists under this arrangement. A modification of the general policy of the Manhattan District Safety Branch to include safety in planning and design was initiated in September 1946 by directive from Office, Chief of Engineers.

SI-5. Specific Policies. - There was no change in status in this paragraph from that shown in the basic history.

SI-6. Safety Regulations. - The Corps of Engineers Manual, "Safety Requirements for Excavation, Building and Construction", was revised on 1 January 1946 and the title changed to "Safety Requirements". (See App. CS-3).

SI-7. Effect of Security on Safety. - Security requirements still restricted the activities of the Safety and Accident Prevention Program, however, the revelation during this period that fissionable materials were being processed by the Manhattan District allowed the circularizing of hazard warnings, accident experience data and the dissemination of information heretofore not permissible. (See App. CS-5 d, e, f, g, h and i).

~~SECRET~~

SUPPLEMENT TO SECTION 2 - OCCUPATIONAL SAFETY PROGRAM

S2-1. General. - There have been no major changes in the functions of the occupational safety program during this period. Such changes as have taken place have been gradual, the principal one has been a relinquishing of the operation functions and further development of the engineering approach at a staff level. Emphasis has been placed on administrative and technical responsibilities of the safety engineers, the development of procedures and the integration of safety in daily operations. During this period safety engineers were required to prepare and submit for approval, written programs for the areas under their jurisdiction.

S2-2. General Procedures. - In the modification of the Manhattan District Safety Branch to Safety and Accident Prevention Division occurring in September 1946, as outlined in Supplement to Section 6, one of the sub-divisions or branches within the division was designated as the Occupational Safety Branch. The modification has not inaugurated any change in the functions of occupational safety from that shown by the basic history, except that the scope of the activities was expanded by a ruling published in District Circular 46-3 which included safety in planning and design.

a. District Inspections. - There was no change in status in this subparagraph from that shown in basic history.

b. Safety Engineers. - There was no change in status in this subparagraph from that shown in basic history.

~~SECRET~~

c. Inspection Reports of Areas. - The form of monthly inspection report from ^A area safety engineers has been changed to exclude the listing of unsafe conditions and acts but to include a resume of the progress of the ^A area based on its policy as stated in the Area program. This change in form of reporting has facilitated the District office in evaluating area safety performance to a greater degree than the ^F form 404 heretofore required.

S2-3. Construction Safety. - The construction program reached a low point during this period as a result of cancellation of many construction contracts. By continued application of, and adherence to safety policies issued under the Safety Program, the District safety record was kept comparatively low.

a. Safety in Design. - There was no change in status in this subparagraph from that shown in basic history.

b. Safety Procedures in the Field. - There was no change in status in this subparagraph from that shown in basic history.

c. Special Problems. - There was no change in status in this subparagraph from that shown in basic history.

d. Efficiency. - There was no change in status in this subparagraph from that shown in basic history.

S2-4. Operations Safety. - There was no change in status in this paragraph from that shown by basic history.

S2-5. Safety Training. - There was fundamentally no change in status in this paragraph from that shown by basic history except, as outlined in paragraph S6-3 wherein the Safety Branch was modified to Safety and Accident Prevention Division. See Appendix AS-10 for the

"S"2.2

~~SECRET~~

~~SECRET~~

functions of this branch and App. CS-1 for the Fiscal Year 1947 Safety Training Program.

S2-6. Accident Reporting. - There was no change in status in this paragraph from that shown in basic history.

"S"2.3
~~SECRET~~

~~SECRET~~

SUPPLEMENT TO SECTION 3 - PUBLIC SAFETY PROGRAM

S3-1. General. - There was no change in status in this paragraph from that shown by basic history.

S3-2. Traffic Safety.

a. Traffic Engineering. - The problems of the traffic engineer were somewhat lessened with the diminishing of construction activity and lessening of the number of employees commuting to and from the Clinton Engineer Works. At the Hanford Engineer Works highway safety in the vicinity of the town of Richland was conducted with the cooperation of state and local authorities.

In Oak Ridge, Tennessee, traffic accident frequency locations were established during the basic history period and a program of remedial and safety correction was pursued with regard to changes in thoroughfares, streets, surfacing, walks, lighting, snow removal and other minor re-location and improvement conditions (See App. AS-1). For comparative accidents per month in 1945 versus 1946 see App. DS-5.

(1) Traffic Counts. - The population in the town of Oak Ridge has decreased to nearly half the peak population however, the traffic volume during May and June 1946 (See App. BS-2) has increased to more than it was during the peak period and traffic accidents have decreased to half those of the preceding year. The increase in traffic volume is explained by the fact that gas and tire rationing was eliminated. The area access gate counts show that commuting traffic has lessened and with it the peak congestion encountered previously has lessened.

"S" 5.1

~~SECRET~~

(2) Elimination of Congestion. - The contributing factors in the elimination of traffic congestion have been eliminated by the resurfacing programs which resulted in a smooth flow of traffic, elimination of dust and the marking of highways, all facilitating better control of the traffic. Many of the work roads which have become highways, have been relocated or abandoned. The program of placing traffic signal lights has been expanded to include some intersections which were previously manned by police officers and some for which signal lights were heretofore unavailable. A major maintenance program was completed, main roads and streets were paved, standardized intersections and turning radii with curbs and gutters have been installed, and many of the temporary board walks and sidewalks have been replaced with permanently surfaced walks.

b. Motor Vehicle Driver Permits. - There was no change in status in this subparagraph from that shown in basic history.

c. Enforcement of Traffic Regulations. - There was no change in status in this subparagraph from that shown in basic history.

d. Government Vehicle Inspection. - There was no change in status in this subparagraph from that shown in basic history.

S3-3. Community Safety.

a. School Safety. - Intense interest in the school patrols is displayed by students and parents alike. Patrol members are rotated so each responsible child has an opportunity to be on the patrol, which is considered an accomplishment. Recognition of the work of the school patrol was given by the Safety Engineers Society of Oak Ridge, who

arranged for and conducted a picnic and day's outing for all patrol members. Safety poster contests have been conducted in all schools. (See App. ES-10). An evaluation of the school program for inclusion of a driver training course was made and each item discussed in detail with each principal and measures were taken to eliminate the unworkable parts of the program. Automobile driver training courses are being held at both the High School and the Junior High School in Oak Ridge.

b. Home Safety. - The approach to the home safety problem has been through community wide appeal, through children in the schools and through publications, pamphlets and periodicals of the operating companies. (See App. ES-14a, b, and c).

(1) The model trailer home has been discontinued.

(2) The model safety home has been discontinued.

(3) A Fire Prevention Home Safety Course was established at Oak Ridge, where instructions were given in a trailer. All Government employees were required to attend. Similar courses were given hospital employees and attendants, dormitory residents and housewives. The total attendance was over 5,000 (See App. ES-15).

c. Recreational Safety. - There was no change in status in this subparagraph from that shown by basic history.

d. National Safety Council Surveys. - There was no change in status in this subparagraph from that shown by basic history.

e. Community Safety Shows. - There was no change in status in this subparagraph from that shown by basic history.

~~SECRET~~

f. Off-the Job Safety. - There was no change in status in this subparagraph from that shown by basic history.

"S"3.1
~~SECRET~~

SUPPLEMENT TO SECTION 4 - OTHER SAFETY ACTIVITIES

84-1. Safety Materials and Equipment.

a. Literature. - In addition to educational materials including posters and technical pamphlets, training films and other media have been provided each month as visual aids. New films and strips have been brought out and wide use of them made by contractors and Government personnel. About 100 safety films have been viewed by audiences aggregating 45,000 persons in 1946 (See App. FS-6).

b. Equipment. - Minor additions to testing equipment have been made available from time to time for use of the safety engineers and widespread use of the equipment has been noted throughout the District during 1946.

84-2. Periodic Meetings of Safety Personnel.

a. Local Meetings. - The District Safety and Accident Prevention Division with field representatives continues to meet periodically to discuss questions of common interest. A conference of Government field safety engineers was held in May 1946, to evaluate the safety program after another year of operation and to assist in formulating new programs for 1946 and 1947 (See App. CS-1).

b. National Conferences. - The National Safety Congress was held in Chicago in 1946, and Special Engineer Corps conferences were held in March 1946 by the Safety Department in Washington, D. C. Safety personnel of the District attended both meetings. Safety engineers of the District attended numerous special regional conferences where routine problems and those of common interest were discussed.

~~SECRET~~

S4-3. Medical Care. - The medical care of residents of Oak Ridge and Hanford, heretofore under the supervision of the Medical Division and staffed with Army doctors, has been changed and residential medical care is now in the hands of private practitioners. During the period following cessation of hostilities and when construction had diminished, many of the first aid stations, which were established at C.E.W. and manned by contractor employees, were closed. Since that time the Safety Division took the initiative in pressing for the opening of five first aid stations with nurses in attendance. Justification for their being established and their performance is determinable in the report of first aid cases treated (See App. DS-7).

S4-4. Contests. - The town of Oak Ridge entered the 1945 and 1946 National Traffic Safety Contest and 1945 and 1946 competition for Fire Prevention Week and won awards in both 1945 contests which are mentioned elsewhere in the Supplement. In 1946, Oak Ridge again competed in the Fire Prevention Activities Contest and won 10th position out of 2300 competing cities. The judging and award of 1946 Traffic Contest has not been made but performance indicated favourable results. American Industrial Transit Company who operate the buses in Oak Ridge has entered a national contest for drivers. Other local contests have been sponsored by civic groups to stimulate home safety (See App. ES-11 and 12).

"S"4.2

~~SECRET~~

~~SECRET~~

SUPPLEMENT TO SECTION 5 - ACCOMPLISHMENTS

S5-1. Occupational Safety Record. - The occupational rates of the Manhattan District for 1946 are below comparable rates for private industry.

a. Magnitude of the District Safety Program. - The number of employee hours of occupational exposure covered by the District Safety Program from 1 January 1945 to 31 December 1946, was as follows:

	<u>1945</u>	<u>1946</u>	<u>To Date</u>
Construction	73,624,908	6,006,327	373,820,537
Operations	135,872,103	65,501,809	309,195,853
Government	<u>7,925,775</u>	<u>7,353,470</u>	<u>27,514,662</u>
Total	217,422,786	77,861,606	701,531,052

b. Methods of Comparison. - In applying the two general types of appraisals to the safety record, in order to evaluate the program, consideration was given to:

- (1) The trend of injury rates during the period.
- (2) Comparison with injury rates of other groups or organizations doing similar types of work (See App. AS-2, 3, 4 and 5).

c. Units of Comparison. - The units of comparison of safety records are the same as those used in the previous period; namely Frequency, Severity, and Fatality Rates. For purposes of clarity, the definition of an injury is as follows:

Disabling Occupational Injury. - Any injury arising out of and in the course of employment which resulted in death, permanent disability, or inability to return to work on the day following the day of accident or any subsequent day. Rules of A.S.A. standard were fol-

lowed to determine proper classification of borderline cases.

d. Trend of District Injury Rates. - Yearly comparisons of the District Safety records show over-all improvement with exception of fatality rate for 1946, as follows:

<u>Frequency Rate</u>	<u>Construction Employees</u>	<u>Operation Employees</u>	<u>Government Employees</u>
1944	6.50	8.09	5.81
1945	5.73	6.88	1.64
1946	4.79	5.75	2.58
<u>Severity Rate</u>			
1944	1.42	0.52	0.75
1945	1.00	0.68	0.01
1946	1.34	0.19	1.77
<u>Fatality Rate</u>			
1944	0.14	0.03	0.11
1945	0.12	0.06	0.00
1946	0.20*	0.00	0.27**

* Caused by one fatality which is also reflected in the Severity Rate.

** Caused by two fatalities - one military personnel and one civilian personnel which is also reflected in the Severity Rate.

The 1946 fatality rate for the District based on the National Safety Council base of 100,000 employees is 6.28 or 1 per 26,000,000 man-hours worked. In 1945 the fatality rate of 18.5 deaths per 100,000 employees was under the National record of 31 deaths per 100,000 employees.

e. Comparison of District Construction Injury Rates. - Comparisons of the Manhattan District's construction contractors' safety record with those of other groups for the period are as follows:

<u>Frequency</u>	<u>Manhattan District</u>	<u>*Corps of Engineers New Military Const.</u>	<u>#National Safety Council</u>
1943	8.43	14.29	15.39
1944	6.50	10.51	18.21
1945	5.73	7.41	19.84
1946	4.79	** 9.06	
<u>Severity</u>			
1943	2.08	2.74	2.48
1944	1.42	2.50	2.49
1945	1.00	1.68	2.27
1946	1.34	** 2.81	
<u>Fatality</u>			
1943	.22	.84	.65
1944	.14	.33	.31
1945	.12		.27
1946	.20	** .38	

~~(See App. A.B.C.)~~

- * Source: Office, Chief of Engineers
- # Accident Facts (Corrected)
- ** Includes Civil Works Only

f. Comparison of District Operations Injury Rates. - The comparison of rates for operational contractors of the Manhattan District:

<u>Frequency</u>	<u>Manhattan District</u>	<u>Ordnance Dept. *</u>	<u>Chemical Warfare</u>	<u>**National Safety Council</u>		
				<u>Chemical Industry</u>	<u>All Industries</u>	<u>All Manufacturing</u>
1943	11.75	8.00	26.20	10.07	14.52	20.04
1944	8.09	6.50	13.80	10.24	14.46	18.40
1945	6.88	4.50	8.00	10.08	13.63	16.74
1946	3.76	7.09	10.65			
<u>Severity</u>						
1943	0.28			1.12	1.20	1.12
1944	0.52			.91	1.21	1.07
1945	0.68			1.06	1.16	
1946	0.19					
<u>Fatality</u>						
1943	.00	.08	.35		.10	.08
1944	.03	.06	.06	.08	.10	.08
1945	.06	.08	.60	.10	.09	
1946	.00	.08	.07			

* Source: Office of the Provost Marshal General

** Source: Private Companies' Reports to the National Safety Council

g. Savings Effected by the District Safety Program. - A comparison for 1945 of the loss incurred by Manhattan District and that which would have resulted had the District rates been as high as those recorded by private industry is as follows:

~~CONFIDENTIAL~~

11 Lives.

1593 Disabling Injuries.

87,000 Employee-days of work.

h. Insurance Savings. - The frequency and severity rates, continuing below those of private industry, the Manhattan District may be credited with substantial insurance savings.

i. Detailed District Safety Records. - The safety records of the Manhattan District are shown in detail by the following appendices.

Graphs of Occupational Injury Rates by Quarters - January 1943 through December 1946.

App. AS-2 -- Manhattan District

App. AS-3 -- Clinton Engineer Works

App. AS-4 -- Hanford Engineer Works

App. AS-5 -- Other Areas

S5-2. Traffic Safety Record. - The community traffic safety record at Clinton Engineer Works is, by comparison, superior to that of other cities of like population. 31 December 1946 marked the 383rd day since a traffic fatality in the ^{town of Oak Ridge} ~~Clinton Engineer Works.~~

A tabulation of deaths from motor vehicles within the Clinton Engineer Works, by years, follows:

1943 - 2

1944 - 9

1945 - 8

1946 - 2

S5-3. Quality of Accomplishment. - By all of the above records and comparisons of the frequency, severity and fatality rates for both

~~SECRET~~

construction and operation, by the computations of savings in lives, injuries and days of work, and by the comparative traffic records, the safety accomplishment of the Manhattan District is shown to be an impressive one. It compares favorably with the records of other organizations and in almost every item has been improving as the work has progressed.

"S" 5.6

~~SECRET~~

~~SECRET~~

SUPPLEMENT TO SECTION 6 - ORGANIZATION

S6-1. Formation. - There was no change in status in this paragraph from that shown by basic history.

S6-2. Development. - There was no change in status in this paragraph from that shown in basic history.

S6-3. Present Organization and Responsibilities. - There have been no major changes in organization, however, there has been a modification of functions and minor shifts in responsibilities. In September 1946 a directive from the Office, Chief of Engineers, designated minor modification wherein the Safety and Accident Prevention Branch was changed to Safety and Accident Prevention Division under which were designated the following branches:

- Occupational Safety Branch
- Training and Off-the-Job Safety Branch
- Fire Prevention and Protection Branch
- Research and Management Branch

The functional duties of these branches are contained in the Organization Chart in Appendix AS-10.

a. The District Safety Engineer. - There was no change in status in this subparagraph from that shown by the basic history.

b. The Occupational Safety Section. - There was no change in status in this subparagraph from that shown by the basic history.

c. The Safety Training and Off-the-Job Safety Section. - There was no change in status in this subparagraph from that shown in basic history.

d. Resident Safety Engineers. - There was no change in status in this subparagraph from that shown in basic history.

e. Clinton Engineer Works. - See Book I, Volume 12 - CEW Central Facilities for Oak Ridge safety promotion and educational program.

f. Hanford Engineer Works. - At the Hanford Engineer Works, safety and fire prevention activities are a function of the plant operating contractor who also administers these functions for the town of Richland. The Safety and Accident Prevention Division coordinates the programs at Hanford.

A central safety committee meets semi-monthly to discuss plant and town safety and to determine general policies of the Safety and Fire Prevention Program. Six sub-committees assist in administering the program and are designated as:

1. Accident Prevention and Investigation
2. Safety Activities and Publicity
3. Safety Standards
4. Special Hazards
5. Health
6. Traffic

A Departmental Safety Committee, an Area Safety Committee and Foremen's Committee are, in addition to above, a part of the safety organization at Hanford Engineer Works. A Committee known as the Traffic Sub-committee of the Central Safety Committee consists of one representative each from Government safety, patrol, transportation, central safety committee and the Safety Division. The committee prepares rules and regulations to arrange for and regulate parking of vehicles, make recommendations for publicity, signs, barricades, bulletins and traffic movement.

The Fire Protection Division is a section of the Safety and Fire Protection Division of the Service Department in the operational

~~CONFIDENTIAL~~

group of Hanford Engineer Works. The function of the Division is to protect HEW and its town against loss of life or property damage by fire.

S6-4. Personnel. - Supplementary changes in personnel to the basic history, covering period 1 July 1945 to 31 December 1946 are as follows:

<u>NAME</u>	<u>POSITION</u>	<u>DATES</u>
Glen M. Hostetter	Chief, Safety Section, Department of Public Safety.	March 1946 to date
Humphrey Gilbert	Post Safety Engineer, Los Alamos, N. M. Chief, Research and Management.	January 1945 to November 1945. November 1945 to March 1946.
H.G. Schraffenberger	Chief, Fire Prevention and Protection Section	August 1945 to Mar. 1946
W. L. Lafferty	Chief, Training and Off-the-Job Safety Branch	May 1946 to date
R. E. Smith	Chief, Fire Prevention and Protection Branch	May 1946 to date

For resident area safety engineers and other personnel of the Manhattan District Safety Staff see App. C-16 of basic history.

S6-5. Contractor's Safety Organizations. - There was no major change in status in this paragraph from that shown in basic history.

S6-6. Cost of the Safety Program. - In lieu of complete cost figures for the safety program of the District for 1946 the cost is estimated at approximately \$250,000 which ^{is} equivalent to \$0.55 per man per month.

"S"6.3

The cost of the contractor safety program, based upon figures available from three contractors, one of which is construction is shown as follows:

<u>Contractor</u>	<u>Exposure 1946</u>	<u>Cost</u>	<u>Cost per employee per mo.</u>
Carbide and Carbon	17,293,194	\$143,724.09	\$1.44
Tennessee Eastman	*14,954,120	67,671.65	.795
	<u>June 1945 to June 1946</u>	<u>June 1945 to June 1946</u>	
J. A. Jones	22,474,717	\$51,657.77	.537

* Eight month period

Contractors show an average cost at C.E.W. of .902 per employee per month.

S6-7. Assistance from Government Agencies and Other Organizations. ←

There was no change in status in this paragraph from that shown in basic history.

SECTION 7 - FIRE PREVENTION AND PROTECTION

7-1. General. - A record of the activities of the Fire Prevention Section was omitted from the basic history of the previous period due to the fact that responsibility was divided between safety and security. The addition of this section to the supplement covers this phase of the safety program.

In August 1945 the responsibility for fire prevention and protection was assigned to the Safety and Accident Prevention Branch of the Manhattan District, the problems of which were undertaken as follows:

a. Organization. - A branch known as the Fire Prevention Branch was established with a chief and an assistant serving on the Safety and Accident Prevention Division Chief's Staff. The field representatives in Chicago, Madison Square Area, California, Dayton, Brookhaven, K-25, Y-12 and X-10 were charged with the responsibility for fire prevention in each facility under their jurisdiction.

b. Scope. - While the scope of the safety activities had been well established, the addition of the responsibility for fire prevention, of necessity, enlarged the field of activities as, heretofore, fire prevention and protection has been a function of the Security Division.

c. Problem. - Of paramount importance was the continuity of production within the District as fire interruptions of production were not permissible. The problem of fire prevention and protection was evident in the main process plants at ORW where the interruption of

~~SECRET~~

production of urgently needed materials was very detrimental. Consequently, a definite fire prevention and protection program was established and the program was rigidly adhered to (See App. ES-14a, b & c). A copy of Fire and Explosion Report form is shown in Appendix DS-6. A Fire Damage Summary Report is included in App. BS-7.

d. Development of the Program. - The most logical way of attacking the problem was along the same lines of that in which the Safety Program was developed, through the contractors, and the first step was to classify the contracts. The classifications made were as follows:

(1) Construction Contractors. - No serious problem was encountered in this classification and no additional personnel was required to include fire prevention and protection activities which were made a part of the regular duties of the safety engineers.

(2) Cost-plus-fixed-fee Operations Contractors. - This class of contractors had established agencies for fire inspections, protection and prevention.

(3) Supply Contractors. - This type of contract embraced supply and/or services in which each contractor performed work for the District or supplies materials or services for the District. They represented a vital link in the chain of production, but, because of security requirements, their problems were hidden in secrecy. These contractors were further classified as those operating in Government-owned plants, those supplying the Government with more than 75% of their output, those performing work on Government-owned materials in private plants, or those

~~SECRET~~

supplying materials which could not be procured elsewhere in the desired quantities. A survey was made, the degree of hazard determined, and a program established for each facility or group of facilities within the above classifications. Fire brigades were established and trained, watchmen were hired, buildings were sprinklered, definite specific directions and orders were prepared establishing lines of authority for plant operators should the necessity arise for calling upon outside agencies. Inspection and maintenance schedules were established for first aid and fire fighting apparatus. Extinguishing facilities were checked and new equipment installed where needed. Sources of water were studied to insure availability and adequacy of supply.

~~SECRET~~

MANHATTAN DISTRICT HISTORY

BOOK I - GENERAL

VOLUME 11 - SAFETY PROGRAM

SUPPLEMENT TO APPENDIX "A"

- AS-1 Sample report of Traffic Engineer
 Charts, Occupational Injury Rates, by Quarters,
 January 1943 through December 1946:
- AS-2 Manhattan District
- AS-3 Clinton Engineer Works
- AS-4 Hanford Engineer Works
- AS-5 Other Areas
- AS-10 Manhattan District Safety and Accident Prevention
 Division, Organization Chart

~~SECRET~~

~~SECRET~~
~~COPY~~

WAR DEPARTMENT
CORPS OF ENGINEERS
OFFICE OF THE DISTRICT ENGINEER
MANHATTAN DISTRICT
OAK RIDGE, TENNESSEE

ADDRESS REPLY TO:
DISTRICT ENGINEER
MANHATTAN DISTRICT
CORPS OF ENGINEERS
P. O. BOX "E"
OAK RIDGE, TENNESSEE

REFER TO FILE NO. **EIDMQ-5**

22 March 1946.

Subject: C.E.W. Traffic Data.

MEMORANDUM to Mr. James R. Maddy.

1. Traffic volumes before and after V-J Day:
 - a. Traffic volumes reached an all-time high during the latter part of June 1945, and continued high until after the Japanese capitulation.
 - b. Congestion on the streets and highways was most pronounced during this same period.
 - c. The highest accident recordings covered a similar period.
2. Gate counts show a marked decrease since July 1945.
 - a. June showed a peak of twenty-three thousand.
 - b. Recent counts show a daily movement of eight thousand five hundred. The gate movements have been fairly constant since November 1945.
3. Vehicular traffic units:
 - a. The total number of passenger cars which were using the streets and highways of C.E.W. has been greatly reduced. The vehicles which were used by the personnel of the construction companies have practically disappeared from the roadways.
 - b. Regarding truck movements, we have definite knowledge that they have been reduced approximately sixty percent. This statement is based on figures furnished by Roads & Streets, and the contracting companies.
 - c. Bus movements have not decreased in quite the same magnitude. However, off-area bus movements have decreased approximately fifty percent to date. On-area bus movements have decreased in almost the same

~~SECRET~~
~~COPY~~

AS-1

~~SECRET~~

Subject: C.E.W. Traffic Data.

22 March 1946.

manner. If we but glance at the storage field where surplus property is displayed for sale, and if we will give attention to the advertisement setting forth further bus service curtailment as appears on page 9 of 21 March 1946 issue of the Oak Ridge Journal, we may readily understand why the bus traffic volumes are decreasing.

d. Heavy equipment other than units used by Roads and Streets and the Utility Maintenance Forces, has practically disappeared from the roads and streets.

4. Factors to be considered when making a "before" and "after" comparison:

a. Accident reporting has improved with a fair degree of constancy since 1 June 1945.

b. Traffic and transportation facilities have been greatly improved in that we now have:

1. Better street and highway surfaces.

2. Improved signs and pavement markings.

3. Signalisation of major intersections.

4. Channelisation of traffic at certain hazardous intersections.

5. Controlled access to highways at specific locations, such as T.E.C. and S.E.W. parking lots.

6. Traffic directional control at certain points of access along our highways, such as the Field Hospital Unit opposite the colored hutments on Scarborough Road.

5. Surveys and Studies.

a. We have conducted numerous speed checks, both urban and rural.

b. We have made obedience checks at signals, stop signs and at railroad crossings.

6. Speed Zones.

a. From our studies we have determined the extent and have caused to be established many speed zones, covering the following:

~~SECRET~~

Subject: C.E.W. Traffic Data.

22 March 1946.

1. Schools and their immediate neighborhoods.
2. Business or commercial districts.
3. The residential districts, both the city proper and the trailer camps.
4. Certain sections of our highways have special speed zoning, such as Scarboro Road between Oak Ridge Turnpike and Bear Creek Road. On this section of Scarboro Road we have a thirty miles per hour zone, with twenty miles per hour stated speed signs at all major intersections.

7. Accidents and Congestion vs. Enforcement.

a. Selective enforcement is being effected by the Police Department. A comparison graph for the last two month of 1945 shows that enforcement follows closely the accident curve. The extra high enforcement peak comes with the release of the men from other duties at other times of the day.

b. High traffic volumes on poor facilities mean congestion, and congestion means accidents. The converse is true.

c. January and February 1946, when compared with the same months of 1945, show a decrease of fifty-one per cent in the total number of accidents.

8. Some rural examples:

a. For that section of Oak Ridge Turnpike between West Village and Arnold Road we had seventy-eight accidents "pinned up" on the map for 1945. To date we have but six for 1946.

b. For Bethel Valley Road between Edgemoor Gate and the White Wing Bridge Road we had twenty-three accidents marked for 1945. We have two to date for 1946.

c. White Wing Bridge Road had sixteen accidents during 1945. We have two recorded for 1946.

d. River Road had nine accidents for 1945. We have one to date for 1946.

9. Most traffic accidents have occurred during the morning and evening peak movements.

a. Internal stream friction has been the most pronounced cause. The speed differential factor has doubtless been the highest for our consideration. Rear end collisions and side swipes have been most numerous.

COPY

~~SECRET~~

~~SECRET~~

COPY

Subject: C.E.W. Traffic Data.

22 March 1946.

A very great number of our accidents, in fact the predominate type of accident, occurred during the reconstruction and the resurfacing of our highways.

b. With the overall reduction in traffic volumes, congestion and accidents being effected, let us at the same time remember that the thirty-five miles per hour signs on our main rural highways have been and are being more or less disregarded. With this in mind we do not hesitate to recommend the removal of the existing speed restriction on certain sections of highways. In doing this we think that the cause of Safety will be enhanced. We shall create respect for our traffic signs. We think that the mental attitude of all drivers will be one of appreciation rather than that of contempt.

10. We recommend:

a. That speed zoning be retained as is in the urban areas.

b. That in certain sections of rural highways, such as Soarboro Road between Oak Ridge Turnpike and Bear Creek, the present thirty miles per hour with marked approach speed of twenty miles per hour be retained.

c. That on Bethel Valley Road between Edgemoor Gate and Soloway Gate the thirty-five miles per hour regulations be retained. (While this section of highway has a good surface, it is too narrow and the alignment is bad.)

11. Speed regulations to be raised:

a. On that section of Oak Ridge Turnpike between Bermuda Road and Arnold Road we recommend that speed restrictions be made to conform with those of the State of Tennessee.

b. The same is recommended for Bethel Valley Road between Solway Gate and the White Wing Bridge Road.

c. The same is recommended for River Road between Edgemoor Gate and Oak Ridge Turnpike.

d. The same is recommended for White Wing Bridge Road between Oak Ridge Turnpike and the White Wing Bridge.

12. In every case the above sections of highways shall be properly signed in accordance with Tennessee State Standards.

~~SECRET~~

COPY

Subject: C.E.W. Traffic Data.

22 March 1946.

a. In addition, suitable signs of informational character should be placed at the beginning and ending of the above described road sections.

/s/ L. A. Bowman
L. A. BOWMAN,
Traffic Engineer.

COPY

COPY

Subject: C.E.W. Traffic Data.

22 March 1946.

a. In addition, suitable signs of informational character should be placed at the beginning and ending of the above described read sections.

/s/ L. A. Bowman
L. A. BOWMAN,
Traffic Engineer.

COPY

OCCUPATIONAL INJURY RATES - MANHATTAN DISTRICT

FREQUENCY RATE

(Disabling Injuries Per Million Employee-Hours)

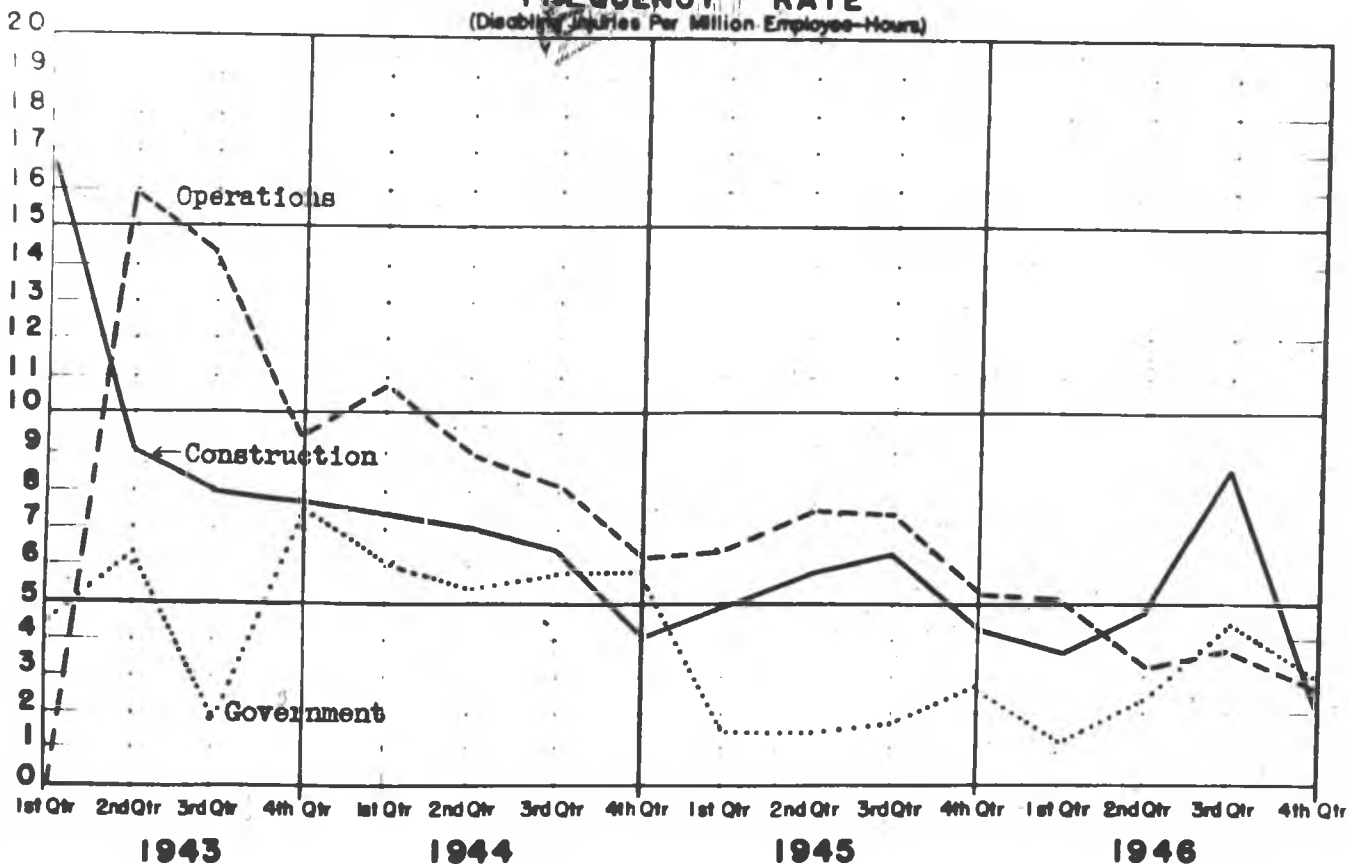

SEVERITY RATE

(Days Lost Per Thousand Employee-Hours)

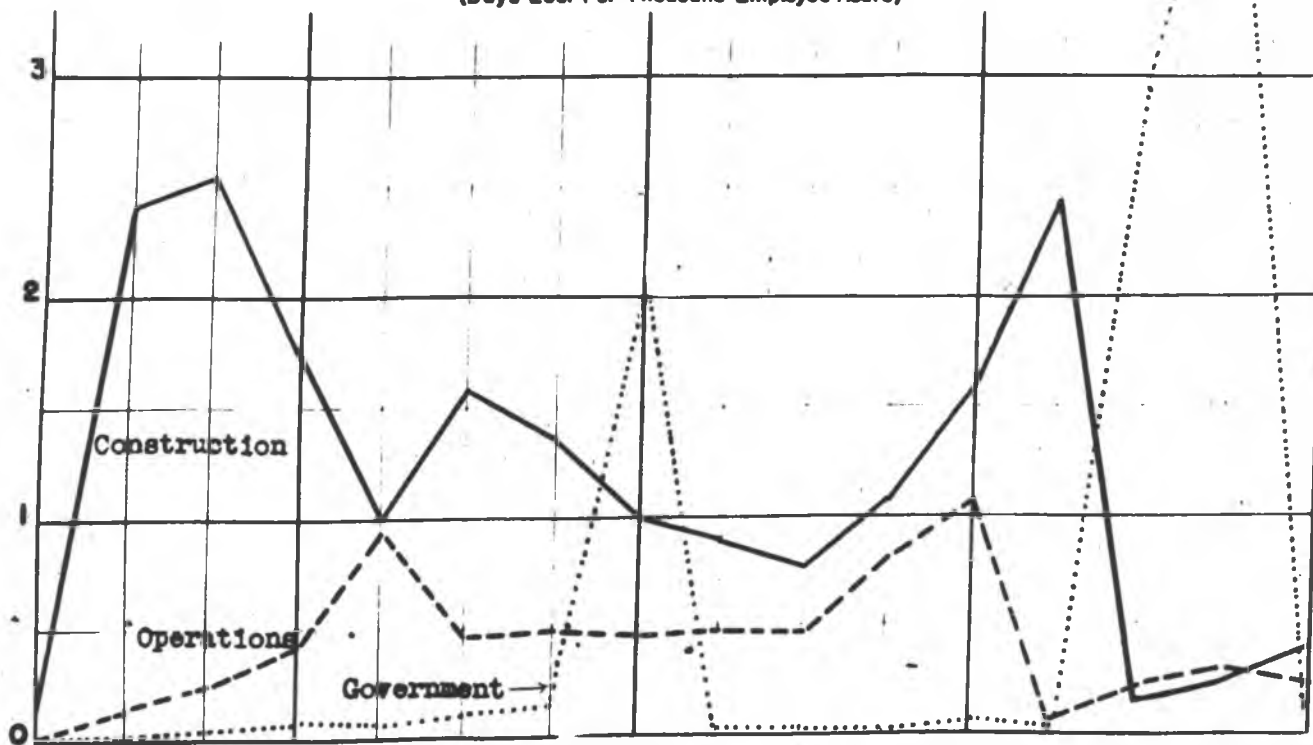

Employee Hour Exposure

Construction

Operations

Government

1943
1944
1945
1946

88,287,680
206,901,622
73,624,908
5,006,327

12,599,964
95,221,977
135,872,103
65,501,809

3,109,685
9,125,732
7,925,775
7,353,470

OCCUPATIONAL INJURY RATES - CLINTON ENGINEER WORKS

FREQUENCY RATE
(Disabling Injuries Per Million Employee-Hours)

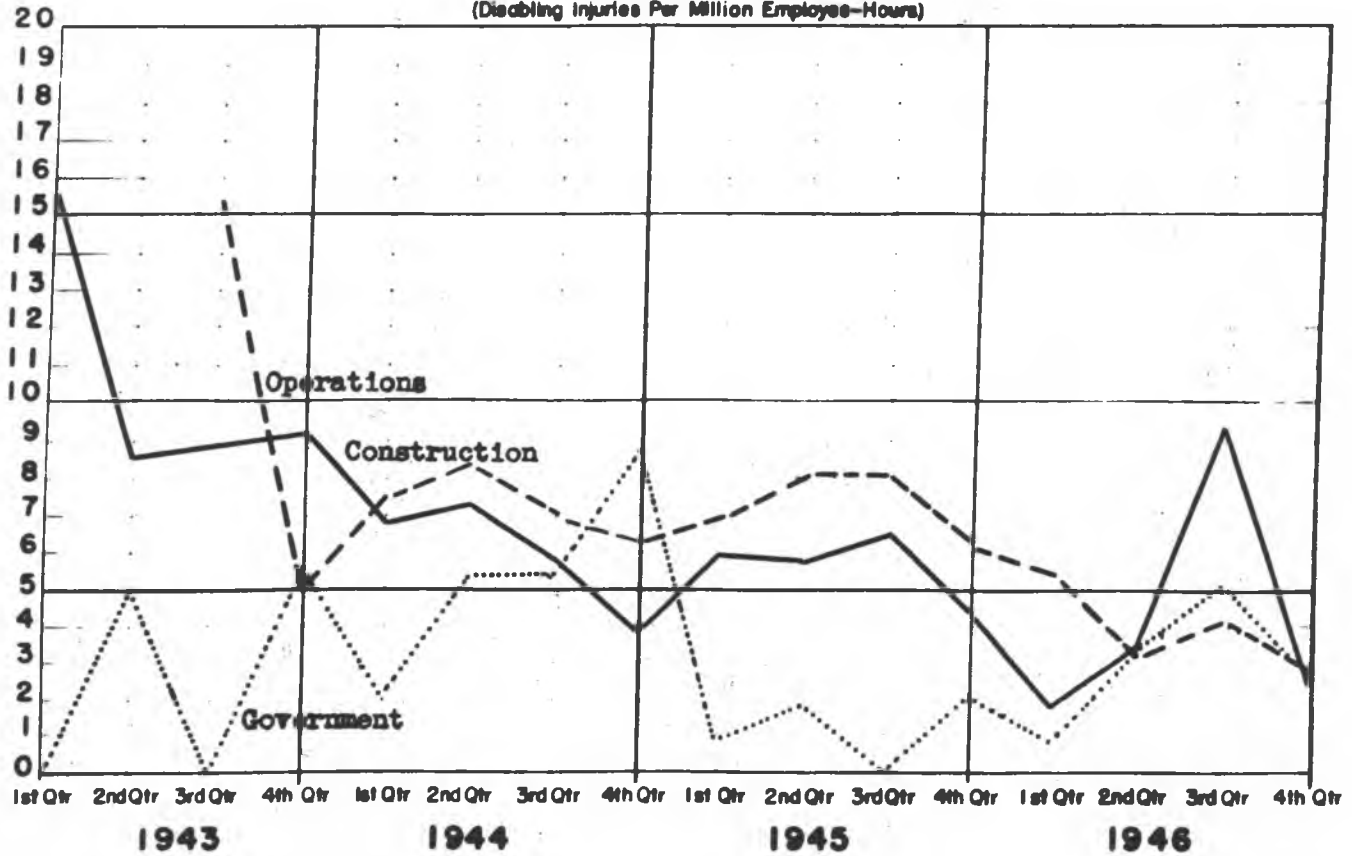

SEVERITY RATE
(Days Lost Per Thousand Employee-Hours)

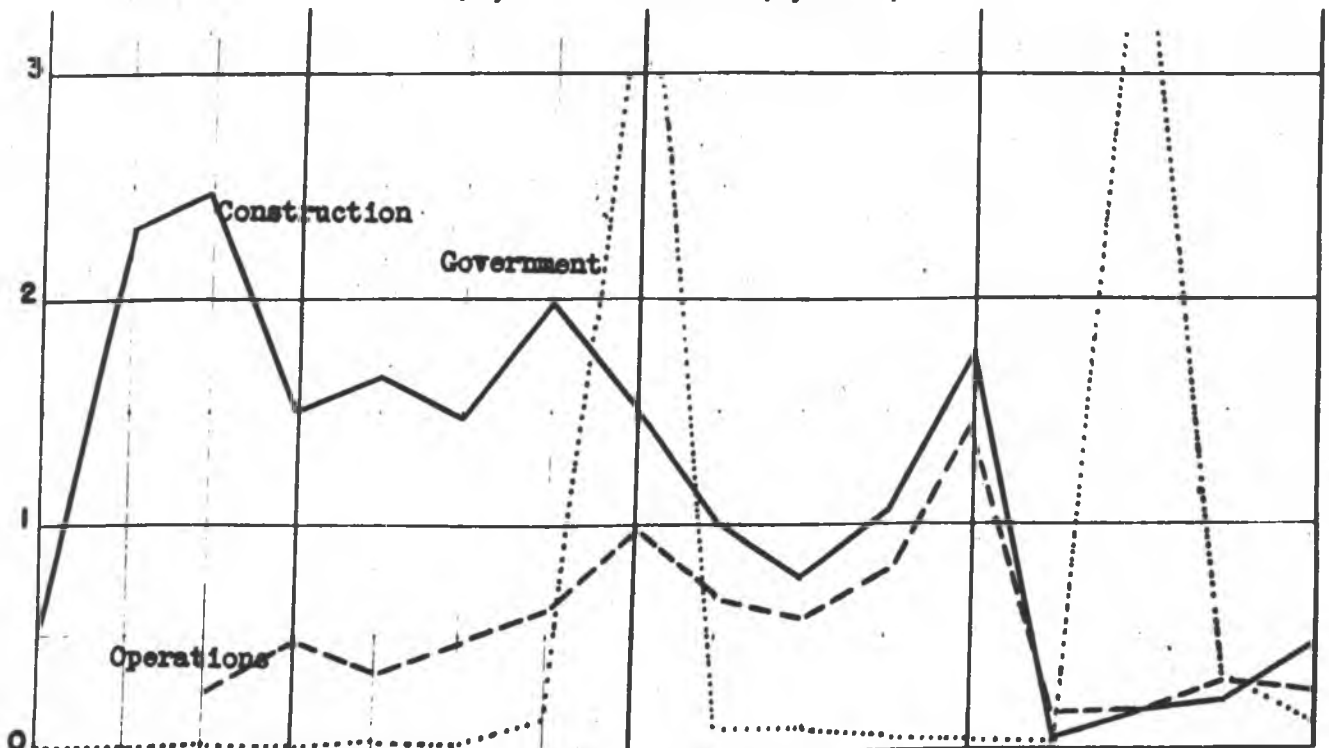

Employee Hours Exposure

1943
1944
1945
1946

Construction

55,737,651
100,407,469
66,857,501
4,179,464

Operations

457,322
60,980,845
93,819,256
47,718,847

Government

1,707,255
4,178,121
4,238,035
4,391,924

OCCUPATIONAL INJURY RATES --- HANFORD ENGINEER WORKS

FREQUENCY RATE
(Missing Injuries Per Million Employee-Hours)

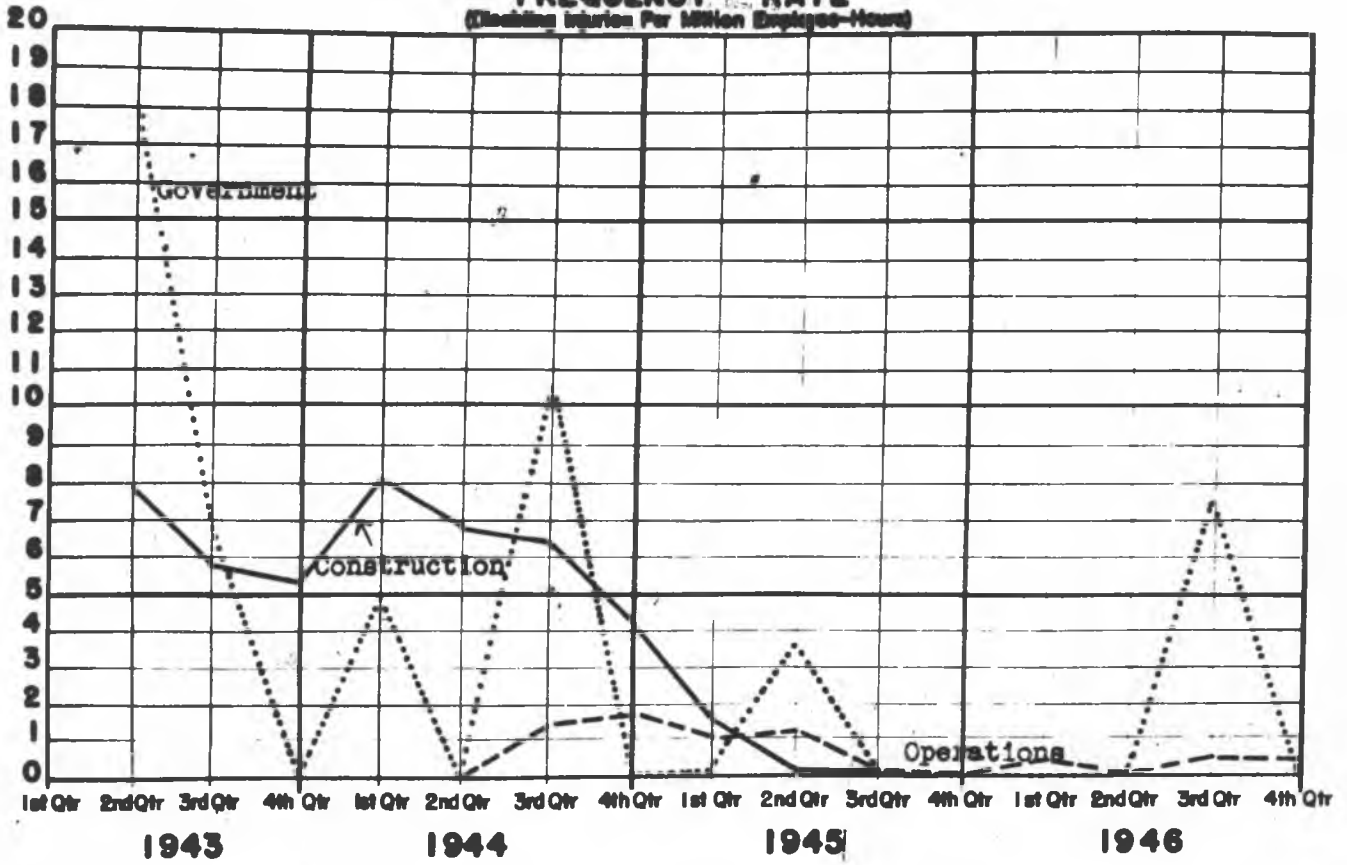

SEVERITY RATE
(Days Lost Per Thousand Employee-Hours)

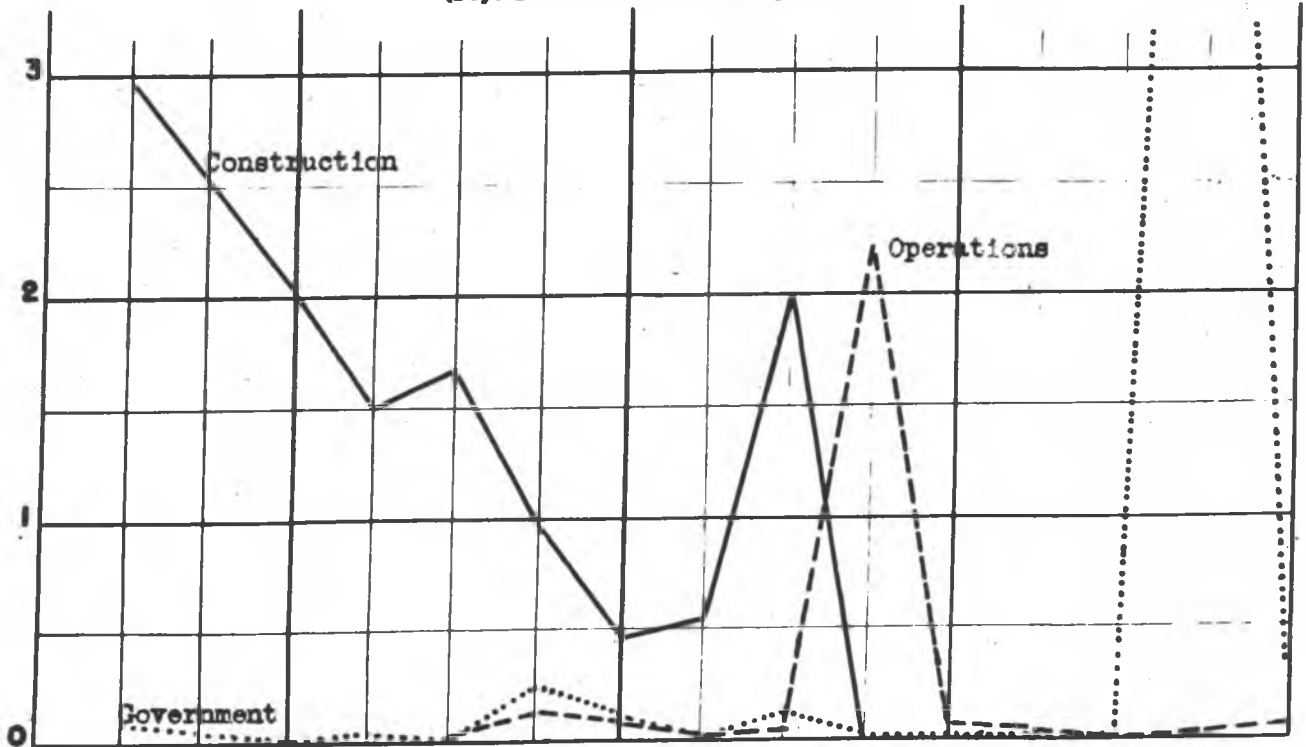

<u>Employee Hours Exposure</u>	<u>Construction</u>	<u>Operations</u>	<u>Government</u>
1943	22,711,761	5,505	391,711
1944	92,277,789	5,348,173	1,217,858
1945	6,055,857	11,781,667	1,145,221
1946		8,708,385	1,079,146

OCCUPATIONAL INJURY RATES---DISTRICT EXCEPT G, E. W. AND H. E. W.

FREQUENCY RATE

(Disabling Injuries Per Million Employee-Hours)

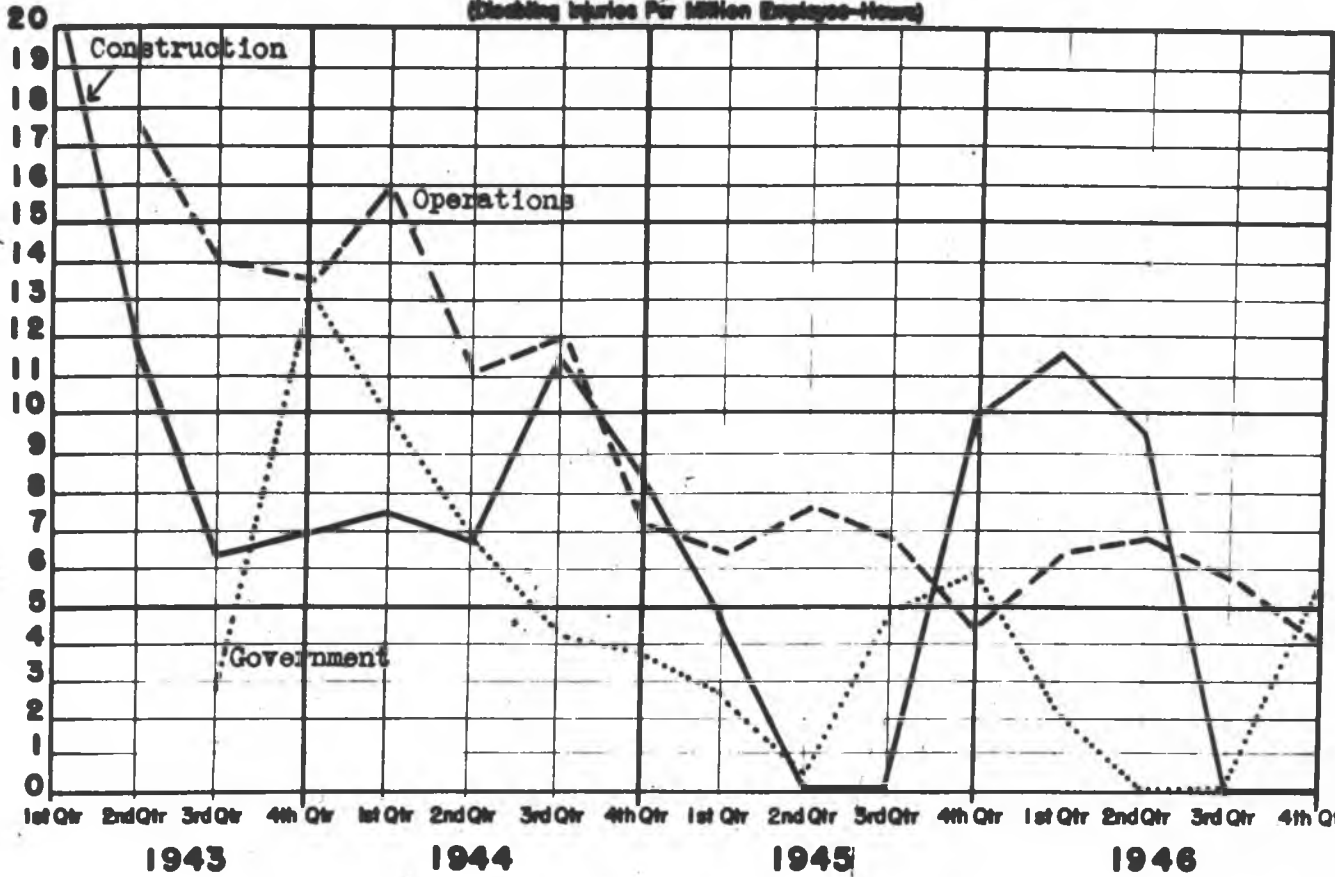

SEVERITY RATE

(Days Lost Per Thousand Employee-Hours)

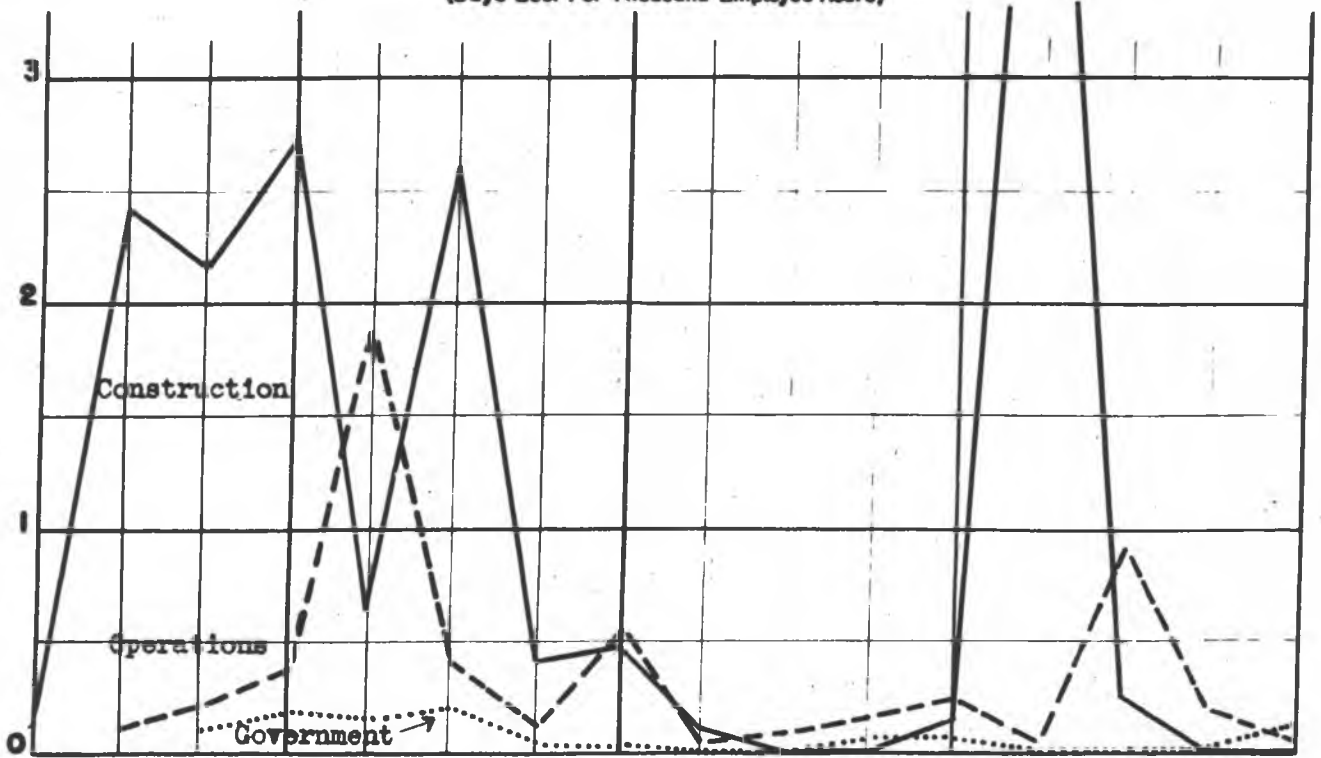

<u>Employee Hour Exposure</u>	<u>Construction</u>	<u>Operations</u>	<u>Government</u>
1943	9,838,268	8,137,137	1,010,719
1944	9,216,364	28,892,959	3,729,753
1945	1,964,073	30,271,180	2,542,519

PERSONNEL
 OFF
 ENL
 P
 S P
 CAF 7
 C P C
 MISCL
 VAC
 TOTAL 13

CHIEF OF DIVISION

Plans, coordinates and effectuates all Safety and Accident Prevention activities of the District. Aids and advises Area Engineers, Officers-in-Charge, and Operating Division Heads in developing and executing effective safety and accident prevention programs and assists on special hazards and problems.

DISTRICT SAFETY ENGINEER, James R. Meddy, Engineer (Safety), P-6
 ASSISTANT DISTRICT SAFETY ENGINEER, K. E. Maraden, Engineer (Safety), P-5

OCCUPATIONAL SAFETY BRANCH

Consults with Area Engineers, Officers-in-Charge, Operating Division Heads, and Contractors' representatives regarding occupational safety activities; cooperates with the Medical Division in combating occupational disease and health hazards. Plans the safety program for Government employees. Determines compliance with Safety regulations and standard or adopted codes and practices.

J. W. S. Rasmussen, Engineer (Safety), P-5
 C. E. McClure, Engineer (Safety), P-4

TRAINING AND OFF-THE-JOB SAFETY BRANCH

Consults with Area Engineers, Officers-in-Charge, Operating Division Heads, Contractors' representatives and others interested or concerned with "off-the-job" safety. Plans, promotes and assists in the execution of off-the-job safety activities. Formulates programs and procedures and surveys and evaluates training safety activities.

Chief, W. L. Lafferty, Engineer (Safety), P-5

FIRE PREVENTION AND PROTECTION BRANCH

Consults with Area Engineers, Officers-in-Charge, Operating Division Heads and Contractors' on all fire prevention and protection plans, policies, and procedures. Cooperates in the development of educational materials. Surveys Area programs and recommends improvements.

Chief, R. B. Smith, Engineer (Safety), P-5

RESEARCH AND MANAGEMENT BRANCH

Responsible for statistical control data, special projects and detailed accident and fire analyses. Furnishes secretarial and clerical assistance. Maintains files. Handles routine administrative details.

Chief, E. Gilbert.
 Administrative Assistant, CAF-9
 Assistant, D. G. Harris,
 Administrative Assistant, CAF-6
 M. E. Crowe Clerk-Steno. CAF-4
 M. I. Kelti Clerk-Steno. CAF-4
 T. J. Russell Clerk CAF-3
 M. A. Mchutt Clerk-Steno. CAF-3
 E. J. Coburn Clerk-Steno. CAF-3

ORGANIZATION CHART

UNIT SAFETY AND ACCIDENT PREVENTION DIVISION

SUBMITTED *[Signature]* DATE 12/31/46
 RECOMMENDED *[Signature]* DATE 12/31/46
 APPROVED *[Signature]* DATE 1-14-46

~~SECRET~~

MANHATTAN DISTRICT HISTORY

BOOK I - GENERAL

VOLUME 11 - SAFETY PROGRAM

SUPPLEMENT TO APPENDIX "B"

- BS-2** Map of Oak Ridge road and street system showing points at which traffic was measured, May - June, 1946.
- BS-7** Manhattan District Fire Damage Summary, December 1946.

~~SECRET~~

MANHATTAN DISTRICT
 Fire Damage Summary
 December 1946

— Cumulative For Year 1946 —

Area	December 1946			THIS YEAR		
	No.	Government	Private	No.	Government	Private
St. Louis	-	-	-	1	\$ 109,946.49	-
Hanford	-	-	-	7	11,554.00	\$ 720.00
Wilmington	-	-	-	1	28,000.00	-
C. E. W. Total	4	\$ 3,092.00	-	34	53,141.08	2,825.00
K-25	3	1,387.00	-	16	41,831.00	-
Y-12	-	-	-	3	350.00	-
Townsite	1	1,705.00	-	15	10,960.08	2,825.00
Santa Fe	1	150.00	-	1	150.00	-
DISTRICT TOTAL	9	\$ 3,242.00	-	44	\$ 202,791.57	\$3,545.00

Prepared by:
 Research and Management Branch
 Safety Division
 U. S. Atomic Energy Commission
 Oak Ridge, Tennessee

13-7

~~SECRET~~

OAK RIDGE, TENNESSEE

ARTERIAL ROADS & STREETS

Prepared by
U.S.D. TRAFFIC SECTION
VEHICULAR TRAFFIC VOLUMES
MAY-JUNE 1946

Note: Traffic count taken over a twenty-four hour period

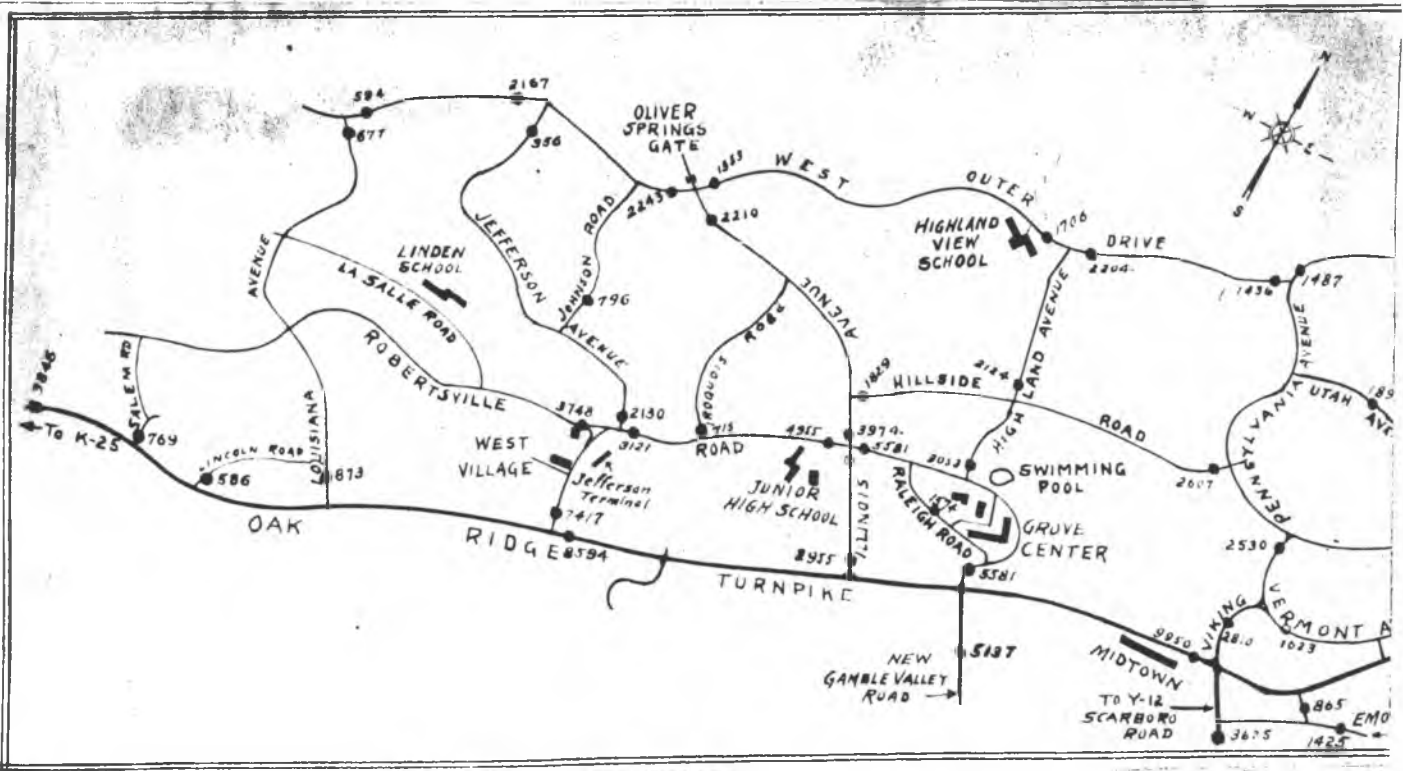
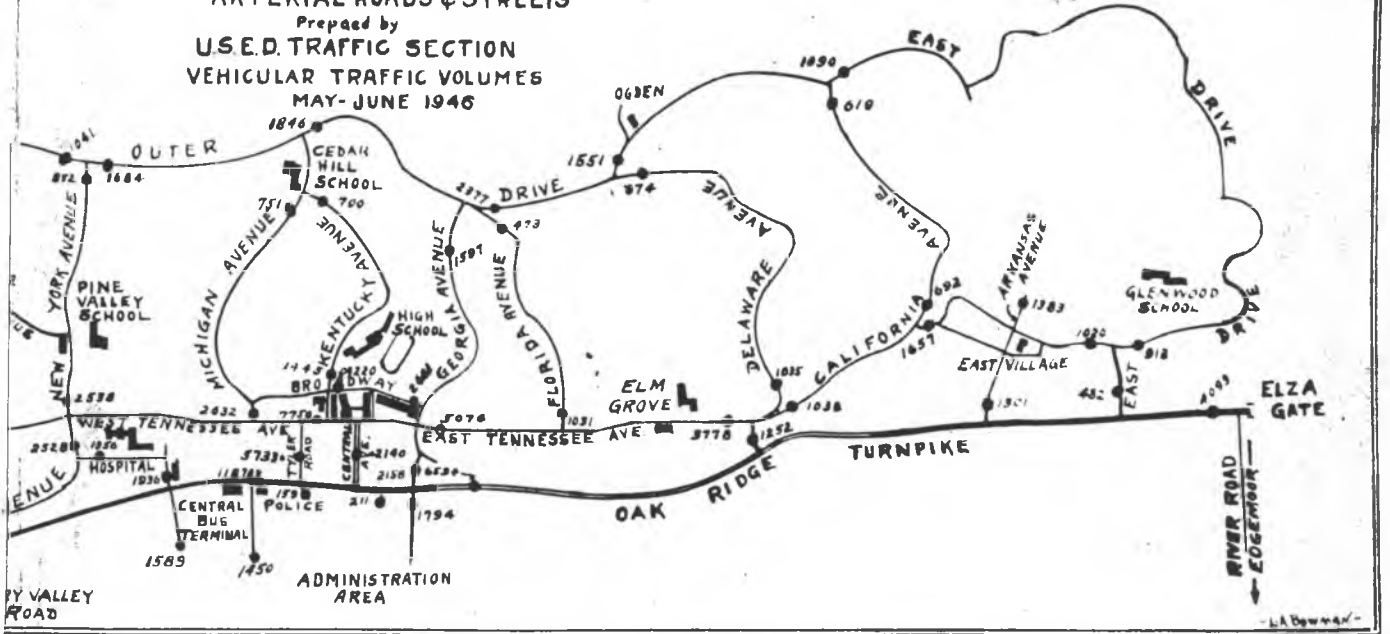

~~SECRET~~

~~SECRET~~
MANHATTAN DISTRICT HISTORY

BOOK I - GENERAL

VOLUME 11 - SAFETY PROGRAM

SUPPLEMENT TO APPENDIX "C"

- CS-1 1946-47 Safety and Accident Prevention Programs
- CS-3 Safety Requirements
- CS-5 Safety Precautions in Handling, Shipping and Storing of:
- d. Fluorine
 - e. Lead
 - f. Mercury
 - g. Handling Chemicals
 - h. Transit Explosion
 - i. Beryllium

~~SECRET~~



SAFETY & ACCIDENT PREVENTION

PROGRAM

FISCAL YEAR

1947

MANHATTAN DISTRICT



ARMY SERVICE FORCES
U. S. Engineer Office
Manhattan District
Oak Ridge, Tennessee

10 June 1946.

EIDMN-1

DISTRICT CIRCULAR LETTER (Safety 46-8)

SUBJECT: Safety and Accident Prevention Program.

TO: All Concerned.

1. Inclosed is a copy of the Manhattan District Safety and Accident Prevention Program for the fiscal year 1947.

2. The program has been developed through revision of the present program after careful consideration of the comments and recommendations from Areas of the District. It is intended to anticipate future needs, and conforms to latest changes in District policy.

3. It is desired that Area Engineers and Officers in Charge establish sound, definite, and comprehensive safety programs commensurate with activities under their jurisdiction, and prosecute these programs vigorously to assure continued improvement in the accident experience of the District.

For the District Engineer:

1 Incl.:
1947 Program

E. H. MARSDEN,
Colonel, Corps of Engineers,
Executive Officer.

DISTRIBUTION:

AE

H

The following Safety Circular Letters are still in effect; all others have been rescinded:

43-1 & Suppl. 1	44-4	45-1	46-1
	44-5	45-2	46-2
	44-10	45-3	46-3
	44-11	45-4	46-4
	44-12 & Suppl. 1	45-5	46-5
			46-6
			46-7

MANHATTAN DISTRICT
SAFETY AND ACCIDENT PREVENTION PROGRAM

Fiscal Year

1947

Submitted

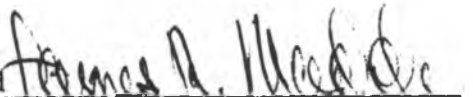

JAMES R. MADDY,
District Safety Engineer.

Recommended



G. M. DORLAND,
Colonel, Corps of Engineers,
Assistant.

Approved



E. E. KIRKPATRICK,
Colonel, Corps of Engineers,
Deputy District Engineer.

1981

TABLE OF CONTENTS

<u>ARTICLE</u>	<u>PAGE</u>
I Definitions	1
II Purpose and Objective	2
III Scope	2
IV The Problem	2
V Organization	3
VI On-the-Job Safety Program	4
VII Off-the-Job Safety Program	7

I Definitions

- Area Engineer** The term "Area Engineer" as used throughout this program will be interpreted to mean the Government representative (officer or civilian) in direct charge of the project, operation or activity.
- Safety** - The term "safety" as used throughout this program will be interpreted to include fire prevention and fire protection.
- Accidents** - The term "accidents" as used throughout this program will be interpreted to include fires, explosions or occurrences which result in personal injury or property damage or the probability of such.
- Safety Department-** The term "safety department" as used throughout this program will be interpreted to mean and include part-time safety representatives, one-man safety organizations, and multi-employee safety organizations.

MANHATTAN DISTRICT
Safety and Accident Prevention Program
Fiscal Year
1947

II Purpose and Objective

1. The purpose of the Manhattan District Safety and Accident Prevention Program is to establish definite basic policies and procedures to be followed by all Areas of the District for the improvement of the safety organization in efficiency, economy and coordination of functions.

2. The program will be an application of sound engineering techniques and practices, and will conform with policies established by the Office, Chief of Engineers, and to accepted training doctrines.

3. The objective of the program is the elimination of accidents, conditions or procedures capable of causing personal injuries, occupational sickness or disease, or factors likely to result in work interruptions, damage or destruction to equipment, materials and property.

III Scope

The Manhattan District Safety and Accident Prevention Program is applicable to all operations of the District, both contract and Government.

IV The Problem

1. Occupational activities of the Manhattan District, traffic accidents and fire, from inception to 1 May 1946, are charged with 77 occupational fatalities and permanent total disabilities, and 4,577 disabling injuries resulting in 5,743,352 man-hours of lost time. Accidents have cost the District, in cash, \$6,000,000. The loss of production, skilled labor, and other related costs amount to considerably more.

2. A recent analysis of occupational injuries occurring within the District indicates that faulty supervision was partially responsible for 83% of the accidents. Forty percent of the accidents indicated non-compliance with "Safety Requirements," and 27% of the accidents were indicative of insufficient knowledge or skill.

3. Off-the-job accidents seriously affect the economy of operation, and intensified activities in this field of accident prevention are warranted.

4. By national averages, the Manhattan District has sustained a loss which is less than one-half of that which might have been expected; yet, the record indicates that many serious deficiencies remain uncorrected.

V Organization

1. The District Safety and Accident Prevention Branch will

a. Exercise staff supervision over all safety activities of the Manhattan District, furnishing advice, coordination and consultation on matters of organization, procedure and methods.

b. Assist in determining needs for research and experimental work in order to establish adequate safety and health controls for all operations. Assistance will be given the District Medical Division in coordinating such research and experimental work and in establishing the controls.

c. Make available to those concerned in the District visual aids and testing equipment, and disseminate to the field available information on new developments pertinent to safety.

d. Consolidate requirements for, order, and distribute, safety education material, forms and publications for Areas and other offices of the District.

e. Collect, review and record all reports of personal injury, property damage, fire and explosion.

f. Compile statistical summaries and comparisons of accident experience, and prepare monthly releases of data to all Areas of the District.

g. Prepare special analyses of accident experience.

h. Review, process and forward to the U. S. Employees' Compensation Commission all information and reports of injury to Government employees which are required by that agency.

2. The Area Engineer is responsible for the conduct of an effective, balanced safety program covering all work under his jurisdiction.

3. The safety organization in each Area or operation will be under the direct supervision of the respective Area Engineer or his deputy.

4. Each Area Engineer will have a full-time, qualified safety engineer on his staff when the Government and contractors' employees supervised have a combined monthly exposure of 80,000 employee-hours, or less if the work involved is especially hazardous.

5. The responsibility for enforcement of safety regulations throughout the entire District will rest on the personnel responsible for the work supervision. Under no circumstances will the responsibility for enforcement of safety regulations be taken from the normal supervisory lines and placed with the safety engineer.

6. The greater part of the direct safety engineering work and field correction are responsibilities of contractors. Government safety engineers encourage progressive engineering techniques which will prevent accidents and fires, and insure, through the Area Engineer, correction of deficiencies in organizations and programs, physical facilities and compliance with safety regulations.

VI On-the-job Safety Program

1. The Corps of Engineers "Safety Requirements," as amended or supplemented, and the Codes of the National Fire Protection organizations shall constitute the minimum safety requirements for all work under the jurisdiction of the Manhattan District.

2. For specific items in construction, maintenance, operation or research activities, where the minimum safety requirements specified in paragraph 1, above, as amended by higher authority or supplemented by the District Safety and Accident Prevention Branch, do not provide coverage or pertain, additional safety requirements will be developed at the site in accordance with the best of recognized and accepted procedures. Such additional safety requirements will be reviewed and approved by the Area Engineer, and forwarded to the District Safety Engineer.

3. Area Engineers will appoint a Board of Investigation to determine the cause, fix responsibility, and recommend preventive measures after each accident, including fire or explosion, resulting in critical or fatal injury, or involving property damage to the extent of \$5000 or more.

4. The development of an adequate safety program is a contractual obligation of contractors and an assigned responsibility of Area Engineers performing or conducting work with Government employees, including military personnel. Safety plans will be expected to include the following where applicable:

a. A written comprehensive safety and accident prevention program will be prepared covering all accident, fire, traffic, health and sanitation phases of safety engineering. A copy of this program will be submitted to the District Safety Engineer.

b. The employment, by the contractors, of a qualified safety engineer who will devote full time to safety, providing the contractors (including sub-contractors) employ 1,000 or more persons, or fewer if engaged in especially hazardous work.

c. Sub-contractors' operations in the scope of the prime contractors' safety responsibilities.

d. Placement on, and acceptance by, management of the responsibility for the safety of all employees and the protection of equipment, materials and property with clearly defined safety policies and active support of the program.

e. An organization wherein the individual responsible for the direct supervision of safety activities will report to a high-ranking management official having jurisdiction over all activities.

f. Provisions whereby the safety department will assist in establishing and directing the program, make surveys and inspections of facilities and activities to determine needs, make special studies where necessary, and assist management and supervision in any other way to carry out the program.

g. Assignment to the safety department of the necessary authority to review and recommend changes in all conditions and practices which affect the safety and health of employees or the protection of equipment, materials and property.

h. Integration of safety engineering with all planning and design for new construction, changes and alterations.

i. Provisions whereby the safety department will be notified of all new sub-contracts and all new work so that timely adjustments can be made in the program to handle adequately the additional activities.

j. Preparation of specifications and review by the safety department, prior to the procurement, of all safety equipment, and provision for an effective system of convenient issue and maintenance of safety equipment.

k. Complete and regular inspections, tests and maintenance of all equipment, machines and tools.

l. Inspection procedures to identify and eliminate unsafe physical conditions, and to discover and correct unsafe acts, which might lead to accidents or fires.

m. Minimum requirements to insure the safe handling of processed or other materials.

n. Protection of health, equipment and property from damage by materials and processes through enforcement of practices and procedures developed by contractors' or Government medical and safety departments.

o. Established lines of authority, and clearly defined and coordinated responsibilities of all parties, including outside agencies which may be utilized in emergencies.

p. Facilities and procedures for notification of designated personnel in the event of accidents and fires.

q. An organized program for evacuation of personnel in the event of emergencies.

r. Adequate first aid equipment and facilities which will be available immediately to cope with any emergency situation which may reasonably be expected to arise.

s. An effective organization of one or more trained emergency brigades composed of volunteer or full time personnel equipped with all necessary facilities to combat immediately any emergency which can be anticipated.

t. Services comparable to those furnished normally by industrial hygiene units to determine the existence of hazards within the scope of the industrial hygienist, and the adoption of measures for the elimination of those hazards through engineering, supplying necessary protective equipment, recommending selection and placement of personnel, or similar methods.

u. Safety educational activities on a continuing and progressive schedule to begin the day an employee is hired, including a good set of safety rules with safety policies and instructions as a part of the orientation program, and with safety integrated in all employee job-training courses.

v. Thorough investigation of all accidents and fires, especially those resulting in injury or property damage, to develop experience, policy and training procedures to prevent recurrences.

w. Traffic:

- (1) The maintenance and use of traffic accident records and spot maps, the periodic observation of traffic flow, speeds and other traffic data to determine solution of high accident location problems.
- (2) A comprehensive study of streets and roadways to determine needs for lighting, centerlining and other pavement markings; installation of regulatory signs; redesign of street intersections, roadways, parking facilities, bus stops; and requirements for traffic control by police.
- (3) Investigation of complaints and referred matters concerning traffic conditions, driver and pedestrian practices, and the recommendations for correction.

VII Off-the-Job Safety Program

1. Each safety department will assist in the promotion of off-the-job safety by the use of the facilities at their command and shall be expected to include provisions in that part of their program for:

a. The reporting of off-the-job accident cases from hospitals, schools, individuals or other sources, and the use of these data for guidance in, and the planning of home, public and school safety activities.

b. Proper publicity through the use of newspapers, house organs, news letters, posters, safety movies, addresses and other media.

c. Taking advantage of all opportunities to encourage community organizations and special groups to set up safety activities commensurate with their interests.

d. A survey of public buildings, schools, concessions, playgrounds and other recreational facilities to determine hazardous conditions or practices, and to plan improvements and appropriate safety features for recreational programs adapted to the various seasons.

e. The inauguration of safety activities in the schools by conducting first aid courses; arranging for State drivers licenses to be issued to students who successfully complete the high school driving course; supplying safety information, publications and films to aid in school safety instruction; improvement in the use and training of school safety patrols; and assistance in the establishment of school safety committees and the extension of their activities.

WAR DEPARTMENT—CORPS OF ENGINEERS
UNITED STATES ARMY

SAFETY REQUIREMENTS



WAR DEPARTMENT • CORPS OF ENGINEERS
UNITED STATES ARMY

Approved by the Chief of Engineers
16 December 1941
Revised 1 January 1946

SAFETY REQUIREMENTS

SAFETY AND ACCIDENT PREVENTION DIVISION
OFFICE OF THE CHIEF OF ENGINEERS



United States Government Printing Office
Washington : 1946

WAR DEPARTMENT,
OFFICE OF THE CHIEF OF ENGINEERS,
Washington, 1 January 1946.

To All Concerned:

The prevention of accidents is of paramount importance to management and workers both government and contract. Loss of productive labor can have serious economic consequences over and above those of death and injury and damage to and destruction of property. A contractor may find that accident costs represent the difference between his bid and that of a successful competitor.

It is equally important that in all work performed by government employees, every possible effort be made to conserve labor, materials and equipment through the prevention of accidents.

The "Safety Requirements" are applicable to all operations of the Corps of Engineers, both contract and government and compliance therewith is an essential responsibility of supervision.



R. A. WHEELER
Lieutenant General
Chief of Engineers

(III)

TABLE OF CONTENTS

	Page
Definitions	8301. 00 3
GENERAL REQUIREMENTS	
Drinking Water	8302. 01 6
Toilet Facilities.....	8302. 02 6
First-Aid Stations and Infirmaries.....	8302. 03 7
Protective Equipment and Practices.....	8302. 04 15
Lighting.....	8302. 05 15
Gas and Smoke.....	8302. 06 16
Salamanders	8302. 07 16
Accident Reporting.....	8302. 08 16
Employment of Safety Engineer.....	8302. 09 16
Miscellaneous.....	8302. 10 16
Storing Materials and Disposal of Waste.....	8302. 11 17
SPECIFIC REQUIREMENTS	
Steam Boilers—Pressure Vessels:	
Inspection.....	8303. 01 18
Excavation:	
Excavations.....	8304. 07 19
Trench Excavation.....	8304. 08 20
Ropes, Cables, Chains:	
Inspection and Use.....	8304. 09 22
Ramps, Runways, Platforms, and Scaffolds:	
General	8305. 01 26
Nails	8305. 02 27
Scaffold Loads.....	8305. 03 27
Pole Scaffolds.....	8305. 04 28
Outrigger Scaffolds.....	8305. 05 31
Horse or Frame Scaffolds.....	8305. 06 32
Ladder Jack Scaffolds.....	8305. 07 34
Carpenters' Portable Bracket Scaffolds.....	8305. 08 34
Window Jack Scaffolds.....	8305. 09 35
Foot Scaffolds.....	8305. 10 35
Guardrails, Toeboards, Screens and Over- head Protection.....	8305. 11 35

(V)

Ramps, Runways, Platforms, and Scaffolds—Continued.		Page
Roofing Devices.....	8305. 12	36
Temporary and Permanent Stairways.....	8305. 13	37
Temporary Floors.....	8305. 14	37
Painters' Swinging Scaffolds.....	8305. 15	38
Boatswains' Chairs.....	8305. 16	39
Suspended Scaffolds.....	8305. 17	40
Needle Beam Scaffolds.....	8305. 19	41
Float or Ship Scaffolds.....	8305. 19	42
Manufactured Scaffolds.....	8305. 20	43
Ladder Specifications:		
General.....	8306. 01	43
Single Rung Ladders.....	8306. 02	45
Single Cleat Ladders.....	8306. 03	45
Extension Ladders.....	8306. 04	46
Stepladders.....	8306. 05	46
Sectional Ladders.....	8306. 06	47
Trestle Ladders.....	8306. 07	47
Extension Trestle Ladders.....	8306. 08	47
Painting:		
Storage of Paints.....	8307. 01	48
Spray Painting.....	8307. 02	48
Electrical Wire and Apparatus:		
General.....	8308. 01	48
Blasting:		
General.....	8309. 01	49
Transportation of Explosives.....	8309. 02	50
Handling of Explosives.....	8309. 03	51
Storage of Explosives.....	8309. 04	52
Drilling.....	8309. 05	54
Loading.....	8309. 06	55
Wiring.....	8309. 07	55
Firing.....	8309. 08	56
Inspection after Blasting.....	8309. 09	56
Misfires.....	8309. 10	56
Fire Prevention and Protection:		
Fire Prevention.....	8310. 01	56
Fire Protection.....	8310. 02	58
Clearing Operations:		
General.....	8312. 01	60
Felling, Bucking.....	8312. 02	61
Decking and Burning.....	8312. 03	62

(VI)

	Page
Flammables:	
General	8313. 01 63
Storage	8313. 02 64
Handling and Use.....	8313. 03 65
Poisons and Harmful Substances:	
General	8314. 01 66
Poison Ivy, Oak, Sumac.....	8314. 02 69
Insects, Vermin, Snakes.....	8314. 03 69
Hot Substances.....	8314. 04 70
Electric and Gas Welding and Cutting:	
General	8315. 01 71
Gas Welding and Cutting.....	8315. 02 71
Arc Welding and Cutting.....	8315. 03 74
Fire Prevention.....	8315. 04 75
Protective Clothing and Equipment.....	8315. 05 76
Ventilation	8315. 06 77
Confined Spaces.....	8315. 07 77
Machinery and Mechanized Equipment:	
General	8316. 01 78
Cranes, Hoists, and Derricks.....	8316. 02 81
Woodworking Machinery.....	8316. 03 83
Floating Plant:	
Inspection and Certification.....	8317. 01 84
Gangways, Guardrails, platforms, etc.....	8317. 02 84
Machinery and Deckgear.....	8317. 03 85
Miscellaneous.....	8317. 04 87
Launches and Motorboats.....	8317. 05 87
Drills	8317. 06 89
Ring Buoys.....	8317. 07 89
Skiffs	8317. 08 90
Life Vests (Work Vests).....	8317. 09 90
Fire Prevention and Protection.....	8317. 10 91
Sanitation—Living Quarters.....	8317. 11 92
Medical Supplies and First Aid.....	8317. 12 93
Motor Vehicles:	
Definition	8318. 01 95
Operator's Permit.....	8318. 02 95
General	8318. 03 95
Equipment	8318. 04 96
Operating Rules.....	8318. 05 98
Transporting Personnel.....	8318. 06 100
Fueling	8318. 07 101
Loading.....	8318. 08 101

INFORMATION FOR CONTRACTORS

All contract work under the jurisdiction of the Corps of Engineers will be performed in compliance with the "Safety Requirements" as established in the following accident prevention clause which is a part of all construction contracts.

(1) **Cost-Plus-a-Fixed-Fee Construction Contracts:** "*Accident Prevention.*—In order to protect the life and health of employees in the performance of this contract, the contractor will comply with all pertinent provisions of the 'Safety Requirements' approved by the Chief of Engineers, December 16, 1941 (a copy of which is on file in the office of the Contracting Officer), and as may be amended, and will take or cause to be taken such additional measures as the Contracting Officer may determine to be reasonably necessary for this purpose. The contractor will maintain an accurate record of, and will report to the Contracting Officer in the manner and on the forms prescribed by the Contracting Officer, all cases of death, occupational disease, and traumatic injury arising out of or in the course of employment on work under this contract. The Contracting Officer will notify the contractor of any noncompliance with the foregoing provisions and the action to be taken. The contractor shall, after receipt of such notice, immediately correct the conditions to which attention has been directed. Such notice, when served on the contractor or his representative at the site of the work, shall be deemed sufficient for the purpose aforesaid. If the contractor fails or refuses to comply promptly, the Contracting Officer may issue an order stopping all or any part of the work. When satisfactory corrective action is taken, a start order will be issued."

(2) **Lump-Sum and Unit-Price Construction Contracts:** "*Accident Prevention.*—In order to protect the life and health of employees in the performance of this contract, the contractor will comply with all pertinent provisions of the 'Safety Requirements' approved by the Chief of Engineers, December 16, 1941 (a copy of which is on file in the office of the Contracting Officer), and as may be amended, and will take or cause to be taken such additional measures as the Contracting Officer may determine to be reasonably necessary for this purpose. The contractor will maintain an accurate record of, and will report to the Contract-

ing Officer in the manner and on the forms prescribed by the Contracting Officer, all cases of death, occupational disease and traumatic injury arising out of, or in the course of, employment on work under this contract. The Contracting Officer will notify the contractor of any noncompliance with the foregoing provisions and the action to be taken. The contractor shall, after receipt of such notice, immediately correct the conditions to which attention has been directed. Such notice, when served on the contractor or his representative at the site of the work, shall be deemed sufficient for the purpose aforesaid. If the contractor fails or refuses to comply promptly, the Contracting Officer may issue an order stopping all or any part of the work. When satisfactory corrective action is taken, a start order will be issued. No part of the time lost due to any such stop order shall be made the subject of claim for extension of time or for excess costs or damages by the contractor."

DEFINITIONS

8301.00

BUILDING AND CONSTRUCTION WORK

The phrase "Building and Construction work" shall mean and include the excavation, construction or erection, alteration and painting of buildings and other structures and all operations in connection therewith; the excavation, construction, alteration and repair of sewers and trenches, and all operations pertaining thereto.

SUBSTANTIAL

The term "Substantial" means construction of such strength, of such material and of such workmanship that the object referred to shall, under normal foreseen conditions or circumstances, withstand all reasonably expected wear, shock, usage and deterioration.

SECURELY FASTENED

The term "Securely Fastened" means that the subject or thing referred to shall be so secured in place that it cannot under normal foreseen conditions or circumstances be accidentally or unintentionally displaced, and that the object or thing referred to will be upheld and will withstand such weight or shock as is reasonably expected from normal use, condition or circumstances.

FACTOR OF SAFETY

"Factor of Safety" is the factor by which working stress must be multiplied to give the ultimate strength of the material.

EQUIPMENT

The term "Equipment" includes all the tools, machinery, devices, derricks, hoists, elevators, scaffolds, platforms, runways, ladders and all such facilities, safeguards and protective construction used in connection with construction operations.

LADDER

The term "Ladder" shall mean an appliance designed for use in ascending or descending at any angle exceeding 50

degrees with the horizontal, usually consisting of two side pieces called side rails, joined at short intervals by cross pieces called rungs, cleats or treads. Any stairway rising at an angle steeper than 50 degrees from the horizontal will be considered a ladder.

FIXED LADDER

The term "Fixed" ladder shall mean a ladder substantially fastened in any fixed position.

SINGLE LADDER

The term "Single" ladder shall mean a ladder consisting of but one section.

EXTENSION LADDER

The term "Extension" ladder shall mean a ladder consisting of two or more sections traveling in guides or brackets so arranged that it may be adjusted to variable lengths.

STEPLADDER

The term "Stepladder" shall mean a ladder having flat treads and so constructed as to be self-supporting.

SECTIONAL LADDER

The term "Sectional" ladder shall mean a ladder consisting of two or more sections so constructed that the sections, when combined, will function as a single ladder.

"A" OR TRESTLE LADDER

The term "A" ladder or "Trestle Ladder" shall mean a ladder consisting of two single ladders hinged or joined at the top to form equal angles with the base.

EXTENSION TRESTLE LADDER

The term "Extension Trestle Ladder" shall mean a ladder consisting of an "A" or "Trestle" ladder with an additional vertical single ladder having parallel sides which is adjustable perpendicularly and is provided with a device to lock it into place.

WALL OPENINGS

The term "Wall Openings" shall mean openings in walls from which there is a clear drop of 6 feet or more, and shall include openings giving access to yard arms or block and tackle doorways and other openings 30 inches or more in height and 18 inches or more in width, the sill or lower edge of which is less than 18 inches above the floor or platform level. Open sides of

buildings between columns, girders, or piers shall not be considered as wall openings.

PAINT MATERIALS

The term "Paint Materials" shall be defined as any material such as paint, varnish, shellac, stains, thinners, lacquers, dryers, size, varnish removers, bronzing liquids, enamels, colors dry or ground in oil, which are used for the preparation, finishing, decoration or protection of surfaces on buildings, structures or any parts thereof.

SCAFFOLD

The term "Scaffold" shall mean an elevated platform used for supporting workmen and/or material in connection with any of the operations coming within the scope of these requirements.

RUNWAY

The term "Runway" shall mean any aisle, walk, or drive constructed or maintained as a passageway for workmen or rolling equipment.

RAMP

The term "Ramp" shall mean an inclined runway.

MACHINERY AND MECHANIZED EQUIPMENT

"Machinery and Mechanized Equipment" shall mean an operating unit or a series of operating units, mobile or stationary, deriving its power for operation from a prime mover generated by wind, water, steam, electricity, compressed air, or internal combustion engine. The prime mover shall also be considered part of the operating unit.

ILLUSTRATIONS

The plates, figures, sketches, and illustrations shown herein and to which reference is made in the text shall not be construed as specifications but shall be considered as types for information or guides only in the construction of such equipment.

GENERAL REQUIREMENTS

SECTION 01—DRINKING WATER

8302.01

A. The dispensing of drinking water to employees shall be in accordance with the following procedure:

1. Drinking water will be obtained only from sources approved by Area or District Engineer.

2. Any of the following dispensing methods shall be used:

(a) Stationary bubbler with guarded orifice installed on approved water line.

(b) Fully enclosed water container and individual paper drinking cups.

(c) Portable sanitary drinking fountains meeting specifications of Procurement Division, Treasury Department.

3. Dipping water out of any container by individual cups, dippers, canteens, etc., is prohibited, and such containers must be provided with a covering so designed and fastened to prevent such use.

4. All containers used to furnish drinking water will be thoroughly sterilized at least once a week, and more frequently if circumstances require, by methods approved by competent medical authorities.

SECTION 02—TOILET FACILITIES

8302.02

A. For every 30 persons or less there shall be provided a privy or closet space so constructed that the occupant thereof will be shielded from view and protected against weather and falling objects. Each privy shall be provided with an adequate urinal trough.

B. At locations where a water-carriage sewerage system or chemical toilets are not available, the privy or closet space shall contain a fly-tight box constructed over a pit latrine or over pails or other suitable containers where pits are impracticable.

C. To render the box fly-tight, all cracks must be closed and the covers and hinges so arranged that the lids drop automatically; also there must be close contact between the base of the box and the ground. Additional fly proofing will be obtained by excavating an area 4 feet wide completely surrounding the pit to a depth of 6 inches. Cover this area with burlap soaked in crude oil, the burlap being placed so that it hangs down into the

pit to a depth of 18 inches. The earth is then replaced over the burlap and tamped down. If burlap is not obtainable, the earth from excavated area may be mixed with crude oil and tamped back in place.

D. Each day the pit will be sprayed with crude oil or sprinkled with lime and the interior of both the box and the pit should be kept thoroughly coated with crude oil at all times.

E. The latrine seats will be scrubbed with soap and water daily, and washed off at least twice weekly with an antiseptic solution.

F. When the contents reach to within 2 feet of the top, pits will be filled with earth to within 6 inches of the surface and covered with a layer of sacking, soaked in crude oil, to extend 3 feet beyond the edges of the pit; the remainder of the pit will then be filled in with earth and the location marked.

G. All privies shall be so located and banked that surface water cannot flood pit.

(NOTE.—This is an adaptation of Army Regulations on the subject.)

SECTION 03—FIRST-AID STATIONS AND INFIRMARIES 8302.03

A. First-Aid Kits:

1. On all projects employing less than 100 workers, 16-unit first-aid kits shall be provided in the ratio of one for each 25 persons employed.

2. Each crew or part of crew working in areas where poisonous snakes are likely to be found shall be equipped with a snake-bite kit. Each snake-bite outfit shall contain:

- 1—plunger type suction syringe.
- 1—large suction cup for flat surfaces.
- 1—small round suction cup for small curved surfaces.
- 1—lancet sealed in glass or metal case.
- 3—ammonia inhalants.
- 3—iodine applicators.
- 1—tourniquet.
- 3—One-inch adhesive compresses.
- 1—tube syringe lubricant.

B. First-Aid Field Station:

On all projects employing more than 100 and less than 300 persons, in a concentrated area, a first-aid field station shall be established. First-aid field stations shall provide a minimum

WAR DEPARTMENT
OFFICE OF THE CHIEF OF ENGINEERS

SPECIFICATIONS

1. Sketch shows only the minimum space requirements. Any suitable alternative arrangement will constitute compliance.
2. The station may be built as a knockdown unit if desired but it is recommended that it be constructed on skids so it may be readily moved from one location to another as the work demands.
3. Walls and ceiling shall be covered with two coats of non-toxic white paint. The floor shall be of impervious construction.
4. The room shall be adequately heated and ventilated; the windows and door shall be well screened, and suitable electric light and outlets shall be provided.

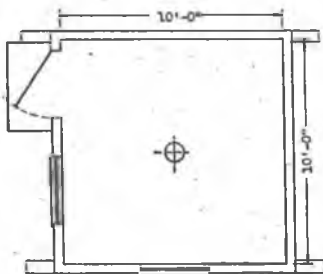

Plan

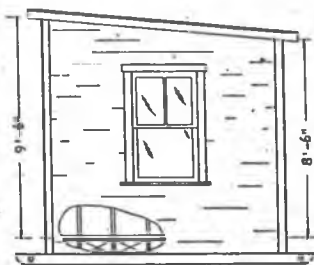

Elevation

SPROL-5

Portable First Aid Station

WAR DEPARTMENT

OFFICE OF THE CHIEF OF ENGINEERS

SPECIFICATIONS

1. Sketch shows only the minimum space requirements. Any suitable alternative arrangement will constitute compliance.
2. The facilities may be built as a part of a new structure, attached to an existing building or may be an independent unit.
3. Walls and ceilings shall be painted with two coats of non-toxic white paint. The floors shall be impervious so as to be easily and sanitarily cleaned. (Concrete, Tile, Linoleum).
4. Rooms shall be adequately heated and ventilated, windows and outside doors shall be well screened, and suitable electric light and outlets shall be provided.
5. Hot and cold running water are required and adequate toilet facilities shall be furnished.
6. Consult detailed specifications for required equipment installation.

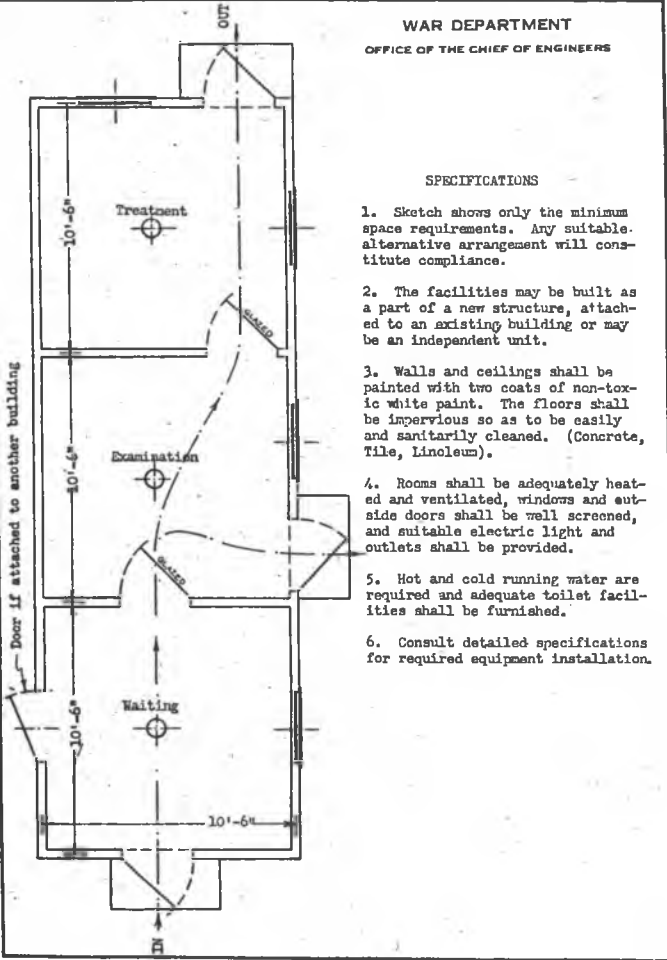

Suggested Plan for an Infirmary

of 100 square feet of floor space with provisions for adequate light, heat, and water; walls and ceilings shall be covered with nontoxic white paint, the floor shall be of impervious construction, and the exterior shall display appropriate insignia. Adequate directional signs shall be established on the project. First-aid field stations shall be of the portable type so that they may be moved from one location to another to meet the needs of various working groups. Each station shall be equipped as follows:

2—enamel hand wash basins.

1—bandage scissors 7".

1—pint iodine in glass-stoppered bottle for dispensing purposes.

1—dozen each 1" and 2" bandage and sterile dressings, 2" x 2" and 4" x 4".

1—bundle absorbent cotton.

1—footrest.

—adhesive tape, $\frac{1}{2}$ " and 1".

—aromatic spirits of ammonia.

—assorted safety pins.

—applicators.

—tourniquet.

—stretcher and blankets.

—alcohol, ether, benzol, or gasoline, if these substances are to be used in cleaning wounds (gasoline containing no tetra-ethyl lead).

—band aids.

C. Infirmary:

On all projects employing 300 to 1,000 persons, an infirmary shall be established having a minimum floor space of 300 square feet for 300 employees and an additional 100 square feet of floor space for each additional 300 employees. This shall consist of one room units with a minimum of four rooms for projects employing 1,000 persons. The infirmary shall be so constructed as to provide reasonable quiet, privacy, good ventilation, light and heat, adequate toilet facilities, hot and cold running water, drainage, electrical outlets, and impervious floors (lineoleum, concrete or tile). Walls and ceilings shall be painted with two coats of white paint (nontoxic) and windows and doors shall be properly screened. Telephone service shall be maintained in the infirmary or immediately adjacent

thereto. The infirmary shall be so located on the project that no person will be required to walk a prohibitory distance for treatment. The infirmary shall be well marked with standard insignia. Adequate directional signs shall be located at various points throughout the project.

1. The following equipment shall be made available for infirmaries on projects employing 1,000 persons:

- 1—glazed sink with hot and cold running water.
- 1—smooth top table, size 2' x 3' or 3' x 4'.
- 1—clock.
- 2—chairs or stools.
 - benches for waiting room.
- 1—cot or couch covered with washable material.
 - recovery cots: 1 per 1,000 men employed; 1 per 30 women employed, screened.
- 2—blankets (dark) wool per cot.
- 1—splint, Thomas type for arm (may be kept in main dressing room only).
 - cabinets for supplies.
- 1—abridged textbook on first aid. Industrial edition. American Red Cross, by Col. C. Lynch and Lt. Col. M. S. Shields (latest edition).
- 1—footrest.
- 1—stretcher.
 - soda mint tablets.
- 2—rubber-covered washable pillows.
- 2—enamel hand wash basins.
- 1—pus basin (kidney shaped).
- 1—waste pail, covered.
- 1—hot water bottle.
- 1—stretcher.
- 1—(or more) screens, folding type of light construction.
- 1—desk, chair, and file.
 - individual towels, drinking cups, soap.
- 1—liquid soap dispenser (optional).
- 1—flashlight.
- 1—bandage scissors 7".
 - bottles of assorted sizes of solutions.
- 1—clinical thermometer.
- 6—eye droppers.
- 1—tourniquet.
 - splints wood (yucca).

- 1—splint, Thomas type for leg (may be kept in main dressing room only).
- zinc oxide ointment, $\frac{1}{2}$ lb. (optional).
- butesin picrate ointment in tubes (optional).
- aspirin tablets (for minor complaints only).
- boric acid, 1 lb.
- magnesium sulphate, 1 lb.
- hand brushes.
- tincture of iodine.
- bandages, 1" and $2\frac{1}{2}$ ", several dozen of each.
- sterile dressing, 2" x 2", 4" x 4" and fluffs.
- absorbent cotton, 1 lb.
- adhesive tape, $\frac{1}{2}$ ", 1", and 3" sizes (quantity depending on demand).
- aromatic spirits of ammonia.
- assorted safety pins.
- applicators and tongue depressors.
- bichloride of mercury tablets (safety type) for antiseptic solution.
- tincture of green soap (optional).
- scarlet red ointment, $\frac{1}{4}$ lb. (optional).
- alcohol.
- gasoline (containing no tetra-ethyl lead), benzol, ether (optional).

2. Equipment for infirmaries on projects employing more than 1,000 persons shall include the foregoing and the following:

- 1—binocular loupe.
- 1—eye spud.
- 1—head mirror.
- 1—gasoline or benzol dispenser if this substance is to be used in the cleansing of wounds.
- 1—sterilizer and heating device, electric.
- 1—emergency table, size $6\frac{1}{2}'$ by $2\frac{1}{2}'$ by 3' high with rubber covered cushion (expensive operating table not required).
- 1—rubber sheet (heavy) $1\frac{1}{2}$ yds. square.
- soaking tanks or basins.
- inexpensive X-ray equipment for installations for 1,000 to 2,000 employees or over (depending on availability and need).
- 1—surgical scissors, straight, $5\frac{1}{2}$ ".
- 1—surgical scissors, curved, $5\frac{1}{2}$ ".

2—scalpels.

1—tissue forceps, 5".

1—thumb forceps, 5".

3—hemostatic forceps, Kelly's catgut and needles, assorted sizes.

—other physical therapy equipment (heat lamps, etc.) depending on local conditions and choice of physician in charge.

1—hair clipper.

—skin sutures.

—rubber gloves.

1—safety razor and blades.

1—needle holder 5".

3. On projects employing more than 1,000 persons, the infirmary shall be supplemented by first-aid field stations in accordance with the following employment table:

Number of employees:	Number of first-aid-stations
1,000 to 2,000-----	1
2,000 to 3,000-----	2
3,000 to 4,000-----	3
4,000 to 6,000-----	4
6,000 to 8,000-----	5
8,000 to 10,000-----	6
10,000 to 12,000-----	7
12,000 to 15,000-----	8

D. Personnel, Qualifications and Duties:

1. *Full Time Physicians.*—All projects employing 1,000 persons or more shall have the full time services of a physician who shall be a graduate of a Class "A" medical school and be duly licensed to practice medicine in the State. The duties of the full time physician shall be: (1) Responsibility for supervision of the infirmary and first-aid stations, all medical and first-aid services and facilities; (2) Render such medical attention as may be necessary beyond the scope of registered nurses and first-aid personnel; (3) Arrange for the proper care and transportation of sick and injured persons to such necessary facilities as are not available on the project.

2. *Registered Nurses.*—Full time registered nurses shall be assigned to each project requiring an infirmary. The duties of the nurses shall be to care for the sick and injured as come within their scope of training and ability under the super-

vision of a physician, and they shall be responsible for the proper maintenance of the infirmary and equipment. The nurse personnel shall be determined in accordance with the following table:

Number of employees:	Number of nurses
300 to 2,000.....	1
2,000 to 3,000.....	2
3,000 to 4,000.....	3
4,000 to 5,000.....	4
5,000 to 7,000.....	5
7,000 to 9,000.....	6

The above tables are minimum requirements and where conditions are of an extraordinary nature, the District or Area Engineer shall determine such additional facilities as may be necessary to adequately and efficiently care for injured employees.

3. *First-Aid Attendants.*—All first aid shall be administered and all field stations manned by first-aid attendants (or registered nurses) holding a current certificate in standard first aid issued either by the American Red Cross or the United States Bureau of Mines. First-aid attendants will be limited to first-aid field treatments and shall not clean up serious wounds, set fractured bones, remove imbedded foreign bodies (especially from the eye) nor administer drugs. First-aid attendants shall promptly and properly transfer to the infirmary all persons suffering other than very minor injuries. First-aid attendants shall promptly arrange to have all persons suffering from other than very minor injuries placed under the care and treatment of a qualified physician.

E. Ambulance Service:

Ambulance service shall be established and maintained for all projects located more than two miles from local ambulance service; projects within that distance shall make arrangements with the local ambulance service. This provision may be modified where there are a relatively small number of men employed or the nature of the work is such that the exposure to serious accidents is slight.

Notices of all available local medical, hospital and ambulance service shall be posted in the infirmaries, first-aid field stations, and field offices.

F. Record of Infirmary and First-Aid Treatment:

A daily record of all treatments in infirmaries and first-aid field stations shall be maintained. In compliance with the foregoing, the following data are required:

Date.	Name of Employer.
Time injured arrived and left.	Foreman's Name.
Case Number.	Description of Accident.
Name of Employee.	Nature of Injury.
Badge Number.	Treated by.
Employee's Occupation.	Treatment Given.
	Lost Time.

These complete records shall be kept on file at infirmaries and first-aid stations and made available for frequent inspections.

SECTION 04—PROTECTIVE EQUIPMENT AND PRACTICES 8302.04

A. Chipper's goggles, welder's goggles, welder's shields, hard hats, rubber boots, safety belts, life lines, life nets, life preservers or jackets, respirators and such other protective equipment and/or clothing, occasioned by the type of work being done, shall be furnished, maintained in serviceable condition, made available to employees and its use enforced.

B. Goggles, respirators, boots and other personal protective equipment shall be properly cleaned and sterilized before being issued to employees.

C. Tetanus antitoxin will not be administered to any injured worker without first making the usual skin test to determine reaction to the serum. If a positive reaction develops and antitoxin is still necessary, the injured shall be desensitized in accordance with the circumstances indicated.

SECTION 05—LIGHTING 8302.05

A. Stairways, corridors, passageways, and working areas shall be kept reasonably and adequately lighted while work is in progress.

B. Where working conditions require the use of artificial lighting it shall be maintained after a shift until workmen have had an opportunity to leave the premises.

SECTION 06—GAS AND SMOKE

8302.06

A. No method of heating shall be used which releases smoke or gas within an enclosure where workers are employed.

B. No fire or open flame device shall be permitted on a project without the approval of the foreman or person in charge.

C. Where smoke pipes from stoves or other heating apparatus pass through combustible walls or roofs, proper insulating sleeves shall be provided.

D. All stoves and other heating apparatus shall be mounted on a fireproof base and have proper fire protection at the rear and sides.

SECTION 07—SALAMANDERS

8302.07

A. Salamanders or other direct fired heaters shall be properly covered and exhaust piped to the outside air.

B. When salamanders are used in inclosed spaces, proper tests for carbon monoxide shall be made and such areas freed of all harmful or toxic gases and fumes before workmen are permitted to enter.

C. Oil-fired salamanders shall be shut down before being moved or refueled.

D. All salamanders shall be equipped with suitable handles or carrying hooks.

SECTION 08—ACCIDENT REPORTING

8302.08

A. Each accident involving an employee resulting in death, permanent total or permanent partial disability or other injury, or occupational disease, arising out of or in the course of employment, which prevents the employee from returning to work on the next calendar day or regular shift, will be promptly reported on forms prescribed by the Contracting Officer.

SECTION 09—EMPLOYMENT OF SAFETY ENGINEER

8302.09

A. Any contractor employing 1,000 or more persons shall provide the services of a qualified Safety Engineer who shall devote full time to accident prevention among his employees engaged on the site.

SECTION 10—MISCELLANEOUS

8302.10

A. All false work, trestles, ramps, special scaffolds and similar temporary structures shall be designed, constructed and main-

tained so as to adequately support the loads imposed thereon. Safe loads shall in no case be exceeded.

B. At entrances to buildings or structures where persons are subject to injury from falling material suitable overhead protection shall be provided. Such protection shall extend from the face of the building or structure to a point not less than eight (8) feet from it and shall be at least two (2) feet wider than the entrance.

C. Projecting rods, dowels, fence pickets and similar arrangements when subject to hazardous contact by persons working above or adjacent thereto shall be properly covered or guarded.

D. All temporary trestles, ramps, fills, roads and other such facilities shall be of sufficient width and designed, constructed and maintained to provide for safe operation. Safe load capacities of such facilities shall be posted.

E. Vehicle trestles or ramps on which foot traffic is permitted shall be provided with a suitable walkway and guardrail.

F. Where vehicles are required to back up to open pits, hoppers, excavations or similar locations, suitable barriers or curbs not less than eight (8) inches high shall be provided.

G. Barricades, signs and warning lights shall be provided at all locations where men are working adjacent to highways or vehicular traffic.

SECTION 11—STORING MATERIALS AND DISPOSAL OF WASTE 8302.11

A. Materials which in the course of building construction are to be stored in locations at or near which workers are employed shall be piled or stacked in an orderly manner to avoid toppling over or being otherwise displaced.

B. No material shall be piled or stacked to a greater height than 6 feet, except in yards or sheds intended especially for storage.

C. When piles exceed 4 feet in height the material shall be placed so that the sides and/or ends of the piles taper back.

D. All boards, planks, blocks, and other material and debris containing projecting nail points, and waste clippings or cuttings of lumber, metal (including pieces of sheet metal, pipe, metal lath, rolled shapes, wire), masonry materials and similar objects shall be *continually removed* from working areas or shall be placed in orderly piles where workmen will not be likely to step or stumble over or fall on them.

E. All stairways, corridors and passageways shall be kept free from loose material and debris.

F. Floors, roofs, and structures shall not be overloaded in the storage and use of materials and equipment.

SPECIFIC REQUIREMENTS

STEAM BOILERS—PRESSURE VESSELS

SECTION 01—INSPECTION

8303.01

A. Steam boilers and all other fired or unfired pressure vessels, having a volume of more than 5 cubic feet and carrying in excess of 15 pounds pressure, shall be inspected by a licensed inspector and approved certificate posted before such equipment is put into operation. Marine and locomotive boilers are included.

Subsequent inspections shall be made at intervals not exceeding 12 calendar months unless otherwise required. Stationary boilers which have been removed, repaired, or overhauled during the 12 calendar months for which approved certificates have been issued shall be inspected by a licensed inspector and a new approved certificate bearing the date of inspection attached thereto before being put into operation. Mobile boilers which have been repaired or overhauled during the 12 calendar months for which approved certificates have been issued shall be inspected by a licensed inspector and a new approved certificate bearing the date of inspection attached thereto before being put into operation. Safety valves, gages, injectors, and other appliances attached to and used in connection with boilers shall be interpreted as part of the boiler except that replacements of such appurtenances adjusted in accordance with approved certificate shall not be interpreted as boiler repairs.

B. Fusible plugs shall be provided on all boilers other than those of the water tube type, and shall be renewed annually.

C. All boilers shall be equipped with approved type water columns, gauge glass and try cocks.

D. All boilers and pressure vessels shall be equipped with an approved type gauge to register the pressure in such boiler or vessel.

E. Approved type safety or relief valves shall be provided on all boilers and pressure vessels. No valve shut-off shall be placed between the boiler or pressure vessel and the safety or relief valve.

F. Safety or relief valves, after being adjusted by the inspector, shall be properly sealed.

G. Safety valves shall be tested at least once a day by raising steam to the popping pressure of the valve. When steam pressure rises to more than 5 pounds above the set pressure before popping, the boiler shall be taken out of service and the safety valve inspected and readjusted.

H. All boiler feed lines shall be equipped with check valves placed as close as possible to the boiler.

I. All boilers shall be equipped with approved blow-off cocks or valves. The blow-off line shall be arranged so that leakage can be observed by the operator. All pressure vessels shall be equipped with a drain valve located at the bottom of such vessel.

J. The discharge from safety valves, relief valves, and blow-offs shall be located so that they do not constitute a hazard to workmen.

K. When cracks, leaks, blisters, or other serious defects develop, boilers or pressure vessels shall be taken out of service immediately.

L. Repairs shall not be made while a boiler or pressure vessel is under pressure.

M. Spark arresters shall be used on all boiler stacks when necessary.

N. Provisions of the ASME Power Boiler Code will generally apply.

EXCAVATION

SECTION 07—EXCAVATIONS

8304.07

A. The sides of excavation 5 feet or more in depth shall be supported by substantial and adequate sheeting, sheet piling, bracing, shoring, etc., or the sides sloped to the angle of repose. Substantial and adequate sheeting, sheet piling, bracing, shoring, etc., shall be based upon calculations of pressures exerted by and the condition of the materials to be retained.

B. Foundations, adjacent to where excavation is to be made below the depth of the foundation, shall be supported by shoring, bracing, or underpinning as long as the excavation shall remain open.

C. Excavated or other material shall not be stored nearer than 2 feet from the edge of the excavation.

D. Bridges or walkways with guardrails shall be provided where men or equipment must cross over trenches, ditches, etc. Temporary guardrails or barricades and red lights or torches, maintained from sunset to sunup, shall be placed at all ex-

cavations which are exposed to paths, walkways, sidewalks, driveways or thoroughfares.

E. Materials used for sheeting and sheet piling, bracing, shoring, and underpinning, shall be in good serviceable condition and timbers used shall be sound, free from large or loose knots, and of the required dimensions. The material specifications are the minimum requirements and the spacing of material members is the maximum allowable in securing trenches against slips, cave-ins, and slides. Where conditions are encountered which require materials of greater strength or closer spacing of timbers to hold the soils securely in place, the sizes of timbers in such cases shall be increased to compensate for the overload.

SECTION 08—TRENCH EXCAVATION

8304.08

A. The following provision for shoring and bracing of trenches shall not apply where solid rock, hard slag, or hard shale is encountered or in which employees are not required to be or to work.

B. The sides of trenches in material, other than those listed in paragraph F, which are 5 feet or more in depth and 8 feet or more in length shall be securely held by shoring and bracing, or sloped to the angle of repose of the material being excavated.

C. If the unit tunnel method is used, the length of earth left in place between the separate unit trenches shall be not less than one-half the depth of the trench and shall be considered as taking the place of shoring and bracing.

D. Whenever or wherever the unit tunnel method is used and where there is apparent danger of slips, slides, or cave-ins, trenches or tunnels in which men are employed shall be shored and braced or otherwise retained as may be necessary to prevent caving.

E. Trenches over 8 feet in length and 5 feet or more in depth in hard compact material, shall be braced at intervals not exceeding 8 feet, with 2-inch by 6-inch planks, or heavier material, placed vertically in the trench opposite each other, backed up by 2-inch by 10-inch planks bearing against the walls at the same intervals as cross braces, struts, or trench jacks. These braces shall, if possible, extend to the bottom of the trench and be supported by horizontal cross braces or struts. Bracing and shoring of trenches shall be carried along with the excavation and must in no case be omitted, except where a mechanical digger is used, the shoring shall be placed within 6 feet of the lower end

of the boom. Undercutting shall not exceed 6 inches on either side of the trench.

F. Trenches in partly saturated, filled or unstable soils or where running material is encountered, such as quicksand, loose gravel, loose shale, or completely saturated material, the sides of the trenches 4 feet or more in depth shall be secured by the use of continuous vertical sheet piling and suitable braces. In trenches over 4 feet in depth wooden sheet piling shall be not less than 2 inches in thickness.

G. Sheet piling shall be held in place by longitudinal beams at vertical intervals of 4 feet. The longitudinal beams shall in turn be supported by the cross braces or struts spaced a maximum of 4 feet. The longitudinal beams shall be in no case less in strength than that of a 4- by 4-inch beam; and when the longitudinal distance between cross braces or struts exceeds 4 feet and less than 6 feet, the longitudinal beam shall be not less than a 4- by 6-inch beam.

H. Vertical braces and longitudinal beams in trenches shall be supported by horizontal cross braces or struts, screw jacks, or timber placed at right angles to both braces, cleated and rigidly screwed or wedged. The timbers or struts shall be not less in strength than the following trade sizes:

Width of trench:	<i>Size of cross braces or struts</i>
1 foot to 3 feet.....	4 x 4 inches
3 feet to 6 feet.....	4 x 6 inches
6 feet to 8 feet.....	6 x 6 inches

I. One horizontal cross brace or strut shall be required for each 4 feet of depth or major fraction thereof.

J. In case it is desired to increase the vertical spacing between longitudinal beams or cross struts, the longitudinal beams, cross struts, and vertical sheet piling shall be increased in size to compensate for the overload.

K. Additional precautions by way of shoring and bracing shall be taken to prevent slides, or cave-ins, when excavations or trenches are made in locations adjacent to backfilled excavations or subjected to vibrations from railroad or highway traffic, the operation of machinery, or any other source.

L. Ladders, extending from the floor of trench excavation to not less than 3 feet above the top ground surface, shall be placed in the trench excavation at 50-foot intervals to be used as a means of entrance and exit therefrom.

ROPES, CABLES, CHAINS

SECTION 09—INSPECTION AND USE

8304.09

A. Fiber ropes used to support a human load shall be inspected before each use. Visual inspection shall be made for abrasion, broken fibers, cuts, fraying, or any other defects. Fiber ropes found to have defects under such inspection and examination shall be removed from such service.

B. Ropes, cables, and chains shall not be used for stresses in excess of the allowable stresses given for each in the table—Safe Loads for Ropes and Chains.

C. Wire ropes or cables shall be inspected at the time of installation and once each week thereafter, when in use, and removed from hoisting or load-carrying service when any one of the following conditions exist:

Defects Which Require Wire Ropes To Be Removed From Load-Carrying Service

- (1) When three broken wires are found in one strand of 6 x 7 wire rope;
- (2) When six broken wires are found in one strand of 6 x 19 wire rope;
- (3) When nine broken wires are found in one strand of 6 x 37 wire rope;
- (4) When eight broken wires are found in one strand of 8 x 19 wire rope;
- (5) When marked corrosion appears;
- (6) Wire rope which has been idle for 3 months or more and subjected to water, moisture, dampness, etc., shall be cut off and inspected for internal corrosion, and if marked corrosion is found it shall be removed from hoisting or load-carrying service;
- (7) Wire rope not mentioned herein, shall be removed from load-carrying service when 4 percent of the total number of wires composing such rope are found to be broken.

D. Wire ropes or cables removed from service under the requirements in items (1) to (7), inclusive, shall not be placed in service again on hoists, cranes, or other such equipment.

E. The ratio between the rope diameter and the drum, block, sheave, or pulley tread diameter shall be such as to allow the rope strands to slide past each other and adjust themselves to

the bend. The economical and absolute critical sheave diameters for steel ropes to be considered for any operating rope are shown in the following table. The "Economical Minimum" sheave diameters should be used for all operating hoist ropes. In no case shall the sheave diameter be less than the "Absolute Critical" sheave diameter for any operating ropes as specified below. For cable sizes not mentioned herein, see manufacturers' specifications for corresponding drum, block, sheave, and pulley diameters:

Economical and Critical Sheave Diameters for Operating Ropes

Sizes	6 x 7	6 x 19	6 x 37	8 x 19
"Economical Min." dia. for operating hoist ropes	36D	24D	16D	20D
"Absolute Critical" dia. for any rope	28D	16D	14D	14D

NOTE.—D=Tread Diameter of Sheaves.

(2) Drums sheaves or pulleys with eccentric bores or cracked hubs, spokes, or flanges shall be removed from service.

F. Connections, fittings, fastenings, parts, etc., used in connection with ropes, cables, or chains shall be of such quality and strength and so attached, connected, fastened, etc., as to provide a safety factor of not less than four. Manufacturers' standard connections shall be used.

G. Running lines of hoisting equipment, located within 6 feet 6 inches from the ground or working level, shall be boxed, railed off, or otherwise guarded, or the operating area restricted, except when loads are moved horizontally.

H. Hooks, shackles, rings, pad eyes, slings, etc., that have been bent or otherwise damaged shall be removed from service.

Safe working load in pounds for single new sling ropes and chains

NOTE.—The safe operating loads in these tables are for each single rope or chain. When used double or in other multiples the loads may be increased in direct proportion.

Diagrams showing how the angle of a sling alters the safe carrying capacity of a load

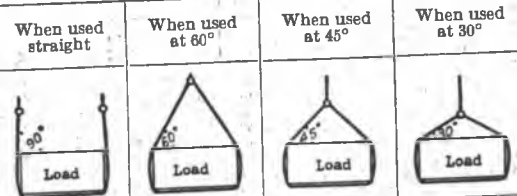

TABLE I.—Flow steel wire rope (6 strands of 19 or 37 wires) If crucible steel rope is used the load must be reduced one-fifth	Diameter	When used straight	When used at 60°	When used at 45°	When used at 30°
		1 1/2"	1,500	1,275	1,050
1 1/4"	2,400	2,050	1,700	1,200	
1 1/2"	4,000	3,400	2,800	2,000	
1 3/8"	6,000	5,100	4,200	3,000	
1 1/2"	8,000	6,800	5,600	4,000	
1 1/4"	10,000	8,500	7,000	5,000	
1 1/2"	13,000	11,000	9,000	6,500	
1 1/4"	16,000	13,500	11,000	8,000	
1 1/2"	19,000	16,000	13,000	9,500	
1 3/8"	22,000	19,000	16,000	11,000	

TABLE II.—Crane chain
(Best grade of wrought iron, hand-made, tested, short link chain)

Diam. of Iron	When used straight	When used at 60°	When used at 45°	When used at 30°
1 1/2"	600	500	425	300
1 1/4"	1,200	1,025	850	600
1 1/2"	2,400	2,050	1,700	1,200
1 3/8"	4,000	3,400	2,800	2,000
1 1/2"	5,000	4,700	3,900	2,750
1 1/4"	7,500	6,400	5,200	3,700
1 1/2"	9,500	8,000	6,600	4,700
1 3/8"	12,000	10,200	8,400	6,000
1 1/2"	15,000	12,750	10,500	7,500
1 3/8"	22,000	19,000	16,000	11,000

TABLE III.—Hemp or manila rope
(Best long fiber grade)

Circum.	Diameter	When used straight	When used at 60°	When used at 45°	When used at 30°
1"	3/8"	120	100	85	60
1 1/8"	1/2"	250	210	175	125
2"	5/8"	360	300	250	180
2 1/4"	3/4"	440	360	300	220
2 3/4"	7/8"	520	420	350	260
3"	1"	620	520	420	300
3 1/4"	1 1/8"	750	625	525	375
3 1/2"	1 1/4"	1,000	850	700	500
3 3/4"	1 1/2"	1,200	1,025	850	600
4 1/4"	1 3/4"	1,600	1,350	1,100	800
5 1/4"	2"	2,100	1,800	1,500	1,050
6"	2 1/4"	2,800	2,400	2,000	1,400
7 1/4"	2 3/4"	4,000	3,400	2,800	2,000
9"	3"	6,000	5,100	4,200	3,000

RAMPS, RUNWAYS, PLATFORMS, AND SCAFFOLDS

SECTION 01—GENERAL

8305.01

A. Scaffolds shall be provided for all work that cannot be safely done from the ground or solid construction except such work as can be safely done from ladders. Scaffolds, platforms, runways, etc., shall be kept free of ice, snow, grease, mud and other such material; where slippery surfaces cannot be avoided, they shall be sanded to prevent slipping.

B. Lumber used in the construction of ramps, runways, platforms, and scaffolds shall be of good quality, reasonably straight grained, free of injurious ring shakes, checks, splits, cross grains, unsound knots, knots in groups, decay, and growth characteristics which materially decrease the strength of the material. The following table shall be used to determine the dimensions of scaffold planks:

Safe center loads for scaffold plank

[Select common eastern spruce, select common Norway pine and select structural eastern hemlock]

Span in feet	2 x 8 dressed to 1½ x 7½	2 x 10 dressed to 1½ x 9½	2 x 12 dressed to 1½ x 11½	3 x 8 dressed to 2½ x 7½	3 x 10 dressed to 2½ x 9½	3 x 12 dressed to 2½ x 11½
6.....	202	256	309	526	667	807
8.....	151	192	232	395	500	605
10.....	121	153	186	316	400	484
12.....	101	128	155	263	333	404
14.....		110	133	225	286	346
16.....			116	197	250	303

Above values are for planks supported at the ends, wide side of plank face up, and with loads concentrated at the center of the span.

For loads uniformly distributed on the wide surface throughout the length, the safe loads may be twice those given in the table.

Loads given are net and do not include the weight of the plank.

If select structural coast region Douglas fir, merchantable structural longleaf southern pine, or dense structural square edge and sound southern pine are used, above loads may be increased 45 percent.

C. All scaffolds constructed of materials other than wood shall be equal in strength and rigidity to the requirements for wood construction.

D. All rolling scaffolds shall be equipped with a suitable device to control movement of the scaffold.

SECTION 02—NAILS

8305.02

A. Nails used in the construction of ramps, runways, platforms, and scaffolds shall be driven full length. Design of construction shall be so that no nail will be subject to direct pull. No nail smaller than an 8d shall be used in the construction of scaffolds and sufficient nails must be driven in at each joint of the scaffold or falsework so that it will carry the loads designed to be imposed on them.

B. The following table will be used to determine the sizes of the nails to be used:

Nails

[Safe working value for lateral resistance of one nail in Douglas fir or southern pine]

Size of nail.....	6D	8D	10D	12D	16D	20D
Value in pounds.....	53	62	83	98	130	175

Suggested rule: Value is approximately 8 times the pennyweight size.

SECTION 03—SCAFFOLD LOADS

8305.03

A. The erection, alteration and removal of all scaffolds, stagings, platforms, runways, and similar equipment shall be done under the direction and supervision of men experienced in scaffold work. No alteration shall be made which will impair the strength of the structure.

B. The principal members of scaffolds, runways, and similar equipment shall be substantially and securely braced.

C. Unless otherwise specified, planks used for platforms, scaffolds, stagings, runways, ramps, etc., shall be of uniform thickness and be laid close together. Such planks may be overlapped or butt jointed. In the former case they shall extend not less than 4 inches beyond the inside face of the bearings, unless securely fastened. Where planks are butt jointed and nailed to supports, an inch and one-half bearing for spans greater than 2 feet, and a three-quarter inch bearing for spans 2 feet or less, are permitted. Where planks project more than one-tenth of their length beyond the bearing they shall be securely fastened to prevent tipping or railed off over bearings.

D. Ramps and runways shall be not less than two 10-inch planks wide. Runways and ramps used for rolling equipment except upon the ground, rough, temporary or finished floor, shall be not less than three 10-inch planks in width. Ramps and runways shall be inclined not more than 1 foot rise in 3 feet run and where the rise exceeds 1 foot in 5 feet run, nailed cleats shall be applied to the top surface. Runways and ramps shall be substantially supported and braced to prevent excessive spring or deflection and shall have planks thereof so placed and secured as to prevent loosening or displacement, with battens on the underside to prevent uneven deflection in the planks.

E. Discarded packing boxes, barrels, piles of loose lumber, or other makeshift material shall not be used for scaffolds or as supports for scaffolds.

F. The platform and all supporting elements of scaffolds, runways, and similar equipment shall be designed to support a minimum uniform load per square foot of platform as follows:

Scaffold loads

Type of scaffold	Uniform load per square foot
Stone masons.....	75 lbs. Stone on scaffold.
Stone setters, 4 stories high.....	30 lbs. No stone on scaffold.
Stone setters, all stories.....	40 lbs. No stone on scaffold.
Bricklayers.....	50 lbs. Stocked.
Carpenter—Miscellaneous.....	20 lbs.
Painters and decorators.....	20 lbs.
Stucco.....	30 lbs. Hod stocked.
Lathers and plasterers.....	30 lbs.
Lathers—Precast work.....	Bay must be designed to carry weight of bay, casts, and men.

NOTE.—If concentrated load is used at any point in the span it shall not exceed one-half the uniformly distributed load.

G. Not more than one thickness of loose brick, tile, or similar material, placed in such a manner as to present its greatest surface (laid flat), shall be used under scaffolds, frames, horses or risers.

SECTION 04—POLE SCAFFOLDS

8305.04

A. The following schedules of designs and dimensions shall be used for all pole scaffolds. Materials of different sectional dimensions may be used, but they shall be of equal or greater strength than that given in schedules. Spacing may be increased if the material and the cross-bracing to be used are increased sufficiently to give strength and rigidity equal to that required by the following schedule:

Pole scaffolds not more than 25 feet in height

Types of pole scaffolds and material dimensions

	Stone masons	Bricklayers	Lathers, plasterers, stucco	Carpenters	Painters, decorators
	75 lbs.	50 lbs.	30 lbs.	20 lbs.	20 lbs.
Poles.....	4" x 4"	3" x 4"	3" x 4"	2" x 4"	2" x 4"
Ledgers.....	2" x 3"	2" x 3"	1" x 3"	1" x 3"	1" x 3"
Stringers ¹	1" x 6"	1" x 6"	1" x 6"	1" x 4"	1" x 4"
Bearers.....	2" x 6"	2" x 6"	2" x 6"	1" x 8"	2" x 6"
Putlogs.....	4" x 4"	4" x 4"	4" x 4"	4" x 4"	4" x 4"
Putlogs on edge nailed.....	2" x 6"	2" x 6"	2" x 6"	2" x 6"	2" x 6"
Braces.....	1" x 6"	1" x 6"	1" x 6"	1" x 4"	1" x 4"
Spacing poles:					
1. Long.....	7'-0"	8'-0"	8'-0"	8'-0"	8'-0"
2. Cross.....	5'-0"	5'-0"	5'-0"	5'-0"	7'-0"
Spacing ledgers, vertical spacing.....	4'-6"	4'-6"	6'-3"	7'-0"	7'-0"
			Putlogs and bearers approx. middle of span		
Planking.....	2" x 10"	2" x 10"	1 1/4" x 12"	2" x 10"	2" x 10"
Toeboards.....	2" x 6"	2" x 6"	2" x 6"	1" x 6"	2" x 6"
Toeboards nailed in center.....	1" x 8"	1" x 8"	1" x 8"	1" x 8"	1" x 8"

¹ Members which do not carry putlog or bearer load are designated as stringers.

B. Scaffolds over 25 feet and up to 64 feet in height:

Stone masons' poles.....	4" x 6"
Bricklayers' poles.....	4" x 4"
Plasterers' poles.....	4" x 4"
Carpenters' and miscellaneous poles.....	3" x 4"
Painters' poles.....	3" x 4"

C. Members which do not carry putlog or bearer load are designated as stringers.

D. The minimum width of carpenters', painters', decorators', and miscellaneous platforms shall be two, 2- by 10-inch planks.

E. Platforms for masons and bricklayers shall not be less than 4 feet in width, unless space will not permit.

F. Pole scaffolds for work heavier than stone masons' pole scaffolds shall have a factor of safety not less than four and shall conform to the general requirements for masons' pole scaffolds.

G. The lower end of the poles or uprights shall rest upon a firm foundation and shall be secured against lateral displacement.

H. Spliced poles shall be squared at the butt joints, made continuous and uniformly strong throughout their lengths with securely nailed or bolted cleats.

I. There shall be not less than two cleats to each splice or joint and shall be of sound wood not less than 30 inches long, 1 inch thick and of the width of the poles, placed so as to overlap the abutting ends of each pole by not less than 15 inches and securely fastened to the poles at least on two sides.

J. Ledgers shall be not less than 1 inch thick and 8 inches wide, unless otherwise specified, extend over two consecutive pole spaces and shall overlap the poles not less than 4 inches. They shall be left in position to brace the poles as the platform is raised with the progress of the work.

K. Ledgers shall be level and their top edges at the same height as the bottom of the openings in the wall for putlogs.

L. Ledgers that carry heavily loaded platforms shall be reinforced by bearing blocks securely fastened to the poles.

M. Ledgers shall be securely nailed or bolted to each pole and where possible shall be nailed or bolted to the inside of the poles or uprights.

N. Where two ledgers overlap on the same pole they shall be securely fastened and where two ledgers meet at right angles one shall be fastened with its ends sawed flush with the pole, the other overlapping in the usual manner.

O. Putlogs shall be square or rectangular in cross section and shall project not less than 6 inches over the ledgers. There shall be not less than three putlogs under platform planks and so spaced as to safely carry the load imposed upon them.

P. The ends of putlogs on single pole types, shall be built into the wall and shall not be notched nor cut down.

Q. Putlogs shall project into the wall not less than 4 inches and where windows or other openings are used, shall be rigidly held in place.

R. Two successive lengths of planking shall not abut upon a single putlog. When laid end to end, two parallel putlogs shall be provided not more than 8 inches apart so one putlog will support the end of one plank and the other putlog the abutting end of the other plank.

S. Where the platform planks overlap on a single putlog the lap of both the lower and upper planks shall be not less than 6 inches over the center of the putlog. Platform planks shall project over the putlog at the end of the scaffold not less

than 6 inches beyond the face, but not more than 12 inches, unless securely fastened against slipping or tipping or railed off over bearings.

T. Bearers shall be attached to frame buildings by notching a piece of lumber no less than 2 by 4 inches by 12 inches long to the size of the bearer so it will bear evenly on the 2-inch surface. The plate or piece so prepared shall be nailed securely to the side of the building and the bearer nailed to the plate.

U. Where a scaffold turns a corner, not less than one bearer shall be laid and securely fastened diagonally across the corner, so that one end may rest upon each of the two ledgers that meet at the corner, or by a 2- by 6-inch timber nailed to the outside of the end poles to set as bearer. Poles shall be spaced at shorter intervals and platform planks laid so as to prevent a tipping hazard.

V. Pole scaffolds shall be securely and adequately braced and fastened in such a manner as to prevent swinging away from the building. Diagonal bracing shall be provided to prevent the poles whether spliced or not, from moving parallel to the walls or from buckling in any direction.

SECTION 05—OUTRIGGER SCAFFOLDS

8305.05

A. Outrigger or thrustout members shall be constructed in compliance with the provisions for allowable loads and stresses tables; they shall conform to the general requirements for masons' pole scaffolds and shall not project more than 6 feet from the outer face of the structure. The strength of outriggers or thrustouts shall be not less than a 2- by 10-inch timber on edge.

B. Working platforms suspended from outriggers shall have suspension frames, the vertical members of which shall not be less in size than 2-inch by 6-inch timber, extending not less than 10 inches above the tops of outriggers and fastened to the outriggers by shoulder blocks resting on the outriggers and fastened to the vertical members. Such blocks shall not be less in size than 2-inch by 6-inch by 8-inch timber. The bottom ends of vertical members shall extend not less than 10 inches below the bottom of bearers and shall be fitted with shoulder blocks the same as provided above, upon which the bearers shall be set. The bearer shall be not less in size than 2-inch

by 6-inch timber. The suspended frames shall be securely and substantially braced to prevent excessive sway.

C. The platform shall consist of not less than three 2- by 10-inch planks.

D. Outriggers shall be securely supported, held, and fastened in place at their inner ends and in the openings through which they project by means of U-bolts, spikes, bolts, lashings, anchoring, or other equivalent means.

E. Thrustouts shall not be built into a wall and left with no other support, but shall project entirely through the wall or through windows and be solidly supported and substantially braced.

F. Where pyramiding or built-up scaffolding is done on an outrigger or where it is necessary to extend the outrigger more than 6 feet beyond the face of the structure, the beams shall be of steel or extra heavy timber and shall be substantially supported and securely fastened as required in the preceding paragraphs. In such cases the scaffold proper shall conform to the requirements for pole scaffolds.

SECTION 06—HORSE OR FRAME SCAFFOLDS 8305.06

A. Scaffold horses and frames shall be constructed in conformity to the allowable loads and stresses tables, not to exceed 16 feet in height, and maintained in substantial condition. Nailing extension legs on horses to increase their height or extensions nailed on bearers to increase their width is unsubstantial alteration.

B. Masons' horse scaffolds shall be not less than 4 feet wide. Platform boards shall be not less than 2 inches in thickness by 10 inches wide and shall overlap the frames or horses not less than 4 inches.

C. All horse or frame scaffolds shall be set level on substantial foundations. When built more than one tier high, the horses shall be set in vertical lines, separated at each tier with a continuous 2-inch plank placed under the vertical members thereof with cleats nailed to planks to prevent the end horse slipping off supports and with all parts of the scaffold securely braced to give rigidity to and to prevent excessive swaying of such scaffolds.

D. Horses for stone masons' scaffolds shall be constructed as follows:

	<i>Dimensions</i>
Bearers.....	3" x 4"
Legs.....	1¼" x 4¼"
Braces.....	1¼" x 6"
Half diagonal braces.....	1¼" x 3"

E. The distance between horses shall be not more than 8 feet and shall not be built over three tiers or horses high having a maximum total height of 16 feet.

F. Distance between legs at bottom shall be not less than two-fifths nor more than three-fifths the height of the horse.

G. Squares or frames used to support masons' scaffold planks shall be securely fastened on both sides at the corners with not less than 1- by 4-inch braces and shall have braces on both sides running diagonally from the center of each side to the center of adjacent side. The frames shall have lateral diagonal bracing not less than 1 by 8 inches in size on both the front and rear members of scaffold.

	<i>Dimensions</i>
Bearers.....	2" x 4"
Leg.....	2" x 4"
Braces, at corners.....	1" x 4"
Braces, diagonal from center frame.....	1" x 8"

H. The distance between frames shall not be over 8 feet; and shall not be built more than three tiers or frames high unless properly anchored and equivalent strength and rigidity provided.

I. Hinged frames used as horses to support scaffold shall be constructed similar to square or frames with diagonal bracing. They shall be provided with substantial cables, chains or other suitable methods to prevent spreading at the bottom a distance more than two-fifths the height of the frame. They shall not be used more than three tiers high, placed one over another.

	<i>Dimensions</i>
Bearers (2).....	1" x 8"
Legs.....	1" x 8"
Braces—Diagonal at bottom.....	1" x 4"

J. The distance between frames used as horses will be not more than 6 feet.

K. Material of different sectional dimensions and a different type of construction may be used for horses and frames, pro-

vided they conform to the requirements for allowable loads and stresses.

L. Not more than one tier of horse or frame scaffold shall be placed upon another scaffold. When the working platform of such imposed scaffold is 6 feet or more in height such imposed scaffold shall be securely fastened and substantially braced.

SECTION 07—LADDER JACK SCAFFOLDS

8305.07

A. Ladder jack scaffolds shall be constructed with a factor of safety of not less than 2 and conform generally to the provisions and specifications for ladders and secured against slipping, tilting, or tipping.

B. Ladder rungs shall not be used to support more than one section of plank and not more than 2 employees shall be permitted to work upon such section of planking at the same time.

C. Lapped planks shall be supported by ladder jacks attached to both side rails of the ladder and not to the rungs.

D. No ladder jack shall be used in connection with the triple extension ladders.

E. Platform planks shall be not less than 2 by 10 inches in size, of select structural grade, overlap the outer bearing surface not less than 8 inches and shall have a span of not more than 12 feet.

SECTION 08—CARPENTERS' PORTABLE BRACKET SCAFFOLDS

8305.08

A. Carpenters' portable bracket scaffolds shall be constructed and erected in conformity with the unit stresses and allowable loads tables.

B. The minimum width of platforms on carpenters' bracket scaffolds shall be not less than two 10-inch planks.

C. All brackets shall be built to carry safely at the outermost edge a load of two times the total weight to be placed upon it, but not less than 400 pounds. Where bolts are used for fastening brackets to the building they shall be not less than $\frac{3}{4}$ inch in diameter. The use of lean-to or jack scaffolds over 8 feet in height is prohibited.

D. Brackets shall be securely anchored to the studding and not to the sheeting and they shall be securely braced against spreading or turning. Brackets shall be spaced not more than 10 feet center to center.

SECTION 09—WINDOW JACK SCAFFOLDS 8305.09

A. Not more than one person shall be permitted on a single window jack at any one time.

B. Window jacks used as supporting elements for scaffolds shall be especially designed for such service and have a factor of safety of four (4).

C. All window jacks shall be securely anchored to the structure and braced to prevent spreading or turning.

SECTION 10—FOOT SCAFFOLDS 8305.10

A. Foot scaffolds shall not exceed 36 inches in height, measured from the level upon which the supports are placed.

B. When placed upon other scaffolds or platforms whose elevation is above the surrounding area, such scaffolds shall have a minimum width of one 10-inch plank and a maximum height of 18 inches measured from the supporting platform or scaffold and one tier only small be permitted.

C. Foot scaffolds in excess of 18 inches in height shall have a minimum width of two 10-inch planks and shall be supported on horses.

D. The construction of such scaffolds shall conform to the allowable loads and stresses as given in tables under "Pole Scaffolds."

**SECTION 11—GUARDRAILS, TOEBOARDS, 8305.11
SCREENS AND OVERHEAD PROTECTION**

A. Guardrails shall be provided as follows unless otherwise specified:

1. On platforms, runways, ramps, scaffolds, and similar equipment which are 6 feet or more in height measured from the ground or supporting area, or that are over or adjacent to deep holes, excavations, mortar beds, railroad tracks, furnaces, fluids, vats, high tension electric wires, machinery, or similar sources of danger.

2. Around the unused sides of all openings in roofs, platforms, floors, or shafts.

3. Where spreaders are used in window frames which extend to within 24 inches or less of the floor or door frames, such spreaders shall be substantially secured in place.

4. Wall openings shall be protected by standard railings and toeboards or gates not less than 42 inches high extending to the bottom of the opening.

B. Guardrails shall be not less than 36 inches, nor more than 46 inches in height, measured from floors to the tops of rails, with supporting uprights spaced not more than 8 feet on centers, and both substantially constructed of 2-inch by 4-inch timber. Other spacing or other material or devices may be used provided the strength, protection, and practicability of the construction is equal to or greater than that above specified.

C. Intermediate rails shall be not less than 1-inch by 6-inch boards or equivalent material unless otherwise specified.

D. Toeboards not less than 4 inches, net, in height, constructed of wood or metal shall be around all scaffolds, platforms, floor and shaft openings where guardrails are required.

E. Side screens shall be provided on all scaffolds over 20 feet in height that are adjacent to passageways, or where workmen are employed within 10 feet of the base of the scaffold, and where material is piled on scaffolds adjacent to and higher than toeboards. Side screens shall be made of substantial expanded metal or wire netting, not larger than 2-inch mesh or other equivalent material securely fastened in place.

F. When work is being performed overhead, an overhead protective covering shall be provided on all scaffolds at a height of not more than nine (9) feet above the working platform.

SECTION 12—ROOFING DEVICES

8305.12

A. Devices used in the construction of pitched roofs or construction on pitched roofs, shall be securely fastened in place. Shingling footlocks shall be not less in size than 2- by 4-inch timber secured in place by properly spaced tin strips or other material of equivalent strength not less than 4 inches wide.

B. Crawling boards, ladders, or chicken ladders, provided with hooks, bolts, or solidly fastened cleats on the under side at the upper end to catch over the ridge-pole or otherwise substantially secured, shall be provided as protection against slipping or falling. Cleats shall be provided on crawling boards securely fastened thereto, not less in size than 2 by 1 inches and shall project approximately 2½ inches on each side of the board.

C. Double crawling boards shall be securely bolted together by a hinge bolt or otherwise substantially secured.

D. On roof decks where the sheathing will not provide safe support for workmen, suitable catwalks or temporary decking shall be provided.

SECTION 13—TEMPORARY AND PERMANENT STAIRWAYS 8305.13

A. Temporary and permanent stairways used for construction purposes shall be fitted with substantial and securely fastened treads and tightly floored landings or gratings.

B. Handrails shall be provided on the open sides of stairways and stair landings, except where such stairways and landings are protected by studding or other permanent construction. Toeboards shall be installed around stairwells in addition to railings.

C. Handrails shall be not less than 30 inches in height measured vertically from the front edge of tread of stairway or 36 inches in height from the floor or landing; with supporting uprights spaced not more than 8 feet on centers and both substantially constructed of not less than 2-inch by 4-inch timber or other material and spacing of equal strength and practicability.

SECTION 14—TEMPORARY FLOORS 8305.14

A. Working areas on various floor levels shall be provided with temporary flooring of sufficient strength to support a minimum uniform load of 25 pounds per square foot.

B. Floor joists shall be securely fastened and braced.

C. Floor boards or planks shall be placed close together upon joists and shall extend not less than 4 inches beyond the inside face of the bearing nor more than 1 foot beyond supports unless securely nailed.

D. Temporary working floor areas exposed to an elevation of 6 feet or more shall be provided with guard rails and toe boards as described under "Guardrails, Toeboards, Screens and Overhead Protection."

E. In the construction of all buildings or structures, temporary floors shall be provided not more than two (2) stories or twenty-five (25) feet below levels where employees are working on the structures. At locations over twenty-five (25) feet in height where it is impractical to provide temporary floors, safety nets or belts shall be used.

F. On all buildings three or more stories in height, the floor above the first shall be completely decked over as soon as possible and shall thereafter be kept covered throughout the entire period of construction.

G. The working floor shall be completely decked over.

H. Only such openings as are necessary shall be permitted in temporary floors.

SECTION 15—PAINTERS' SWINGING SCAFFOLDS 8305.15

A. All hooks, ropes, cables, and blocks supporting scaffolds shall have a minimum factor of safety of four (4).

B. Every time the scaffold is erected, it shall be tested by raising the platform about 1 foot from the ground, and loading it with at least four times the maximum weight that will be imposed upon it.

C. The stirrups or hangers shall be of a strength at least equal to steel $\frac{3}{4}$ inch in diameter, and shall be so formed that guard-rails may easily be secured to them.

D. The distance between hangers shall not exceed 14 feet. Where scaffolds having side rails reinforced by steel rods are used, a span of 22 feet shall be permitted.

E. The hooks used to support the scaffold shall be of a strength at least equal to steel having a cross section $\frac{5}{8}$ inch by 2 inches.

F. Hooks, cornice irons, outriggers, or other devices for fastening to the building shall be securely fastened to a reliable object of support, and shall be frequently inspected. Hooks shall be tied so that they cannot slip.

G. The platform, planks, or ladders shall overlap the stirrup or hanger by at least 12 inches. A bar, strip, or other device shall be permanently attached to the platform outside of the hanger to prevent the platform from slipping off the hanger. Scaffold platforms shall have a minimum width of 27 inches and shall be provided with a guardrail.

H. Two or more swinging scaffolds shall not at any time be combined into one by bridging the distance between them with planks or similar connecting links.

I. Means shall be provided to prevent the scaffold from swinging away from the building.

J. Ropes shall be of manila at least $\frac{3}{4}$ inch in diameter, and shall possess a factor of safety of at least ten (10). Where supporting ropes are brought over sharp corners or subjected

in any way to abrasion, they shall be protected at such points by chafing gear. Splicing anywhere throughout the length of ropes or cables is prohibited. Ropes shall be properly spliced into standard 6-inch blocks.

K. A deep hook shall be provided on the lower block to facilitate making safe scaffold hitch. Scaffold hitch shall always be made on hook, never on any building or object other than the scaffold.

L. Steel cable possessing a factor of safety of eight (8) may be used with mechanical hoisting devices.

M. All fiber ropes, steel cables, other hangers, and falls of the scaffolds shall be protected to a height of at least 6 feet above the platform with acid-resisting material, and the ropes or cables shall hang over the outside edge of the scaffold platform when exposed to operations involving use of acids or caustics. Acids and caustics shall not be stored in the same room with scaffold equipment.

N. Not more than two men shall be permitted on the scaffold at the same time.

O. All ropes, slings, and tackle shall be thoroughly and frequently inspected. When not in use, they shall be stored in a dry place.

P. When a swinging scaffold is not in use it shall be lashed securely to the building. Buckets or other loose objects shall be removed from such scaffold immediately upon the cessation of work thereon.

Q. The hauling part of falls on swinging scaffolds shall be held by a man on the ground until scaffold hitch has been made overhead.

SECTION 16—BOATSWAINS' CHAIRS

8305.16

A. Boatswains' chairs used for painting, cleaning, or other operations shall be constructed and erected with the greatest possible care.

B. Boatswains' chairs shall have a hardwood seat at least 10 by 18 inches in size.

C. Suspenders for boatswains' chairs shall be not less than $\frac{5}{8}$ -inch diameter manila rope doubled. The ends shall be passed through holes bored in the seat and then spliced together.

D. When cutting torches or other open flames are used by a man in a boatswain's chair, the suspenders shall be not less than $\frac{3}{8}$ -inch steel cable.

E. Where single lines are used to support boatswains' chairs they shall be manila rope of not less than 1-inch diameter. Where block and falls are used, rope shall be $\frac{3}{4}$ inch spliced into 6-inch blocks.

F. The hauling part of line used to raise and lower chair shall always be within reach of the man using chair.

G. Safety belts shall be worn by men occupying boatswains' chairs, such belt being fastened to the supporting tackle and so arranged that the workman cannot slip out of the seat.

SECTION 17—SUSPENDED SCAFFOLDS

8305.17

A. All scaffold machines shall be of a type approved by the Underwriters Laboratories, Inc. They shall not be used for any other purpose.

B. The moving parts of scaffold machines shall be frequently inspected and shall be exposed to view at all times so that possible defects may be readily detected. Such moving parts shall be so guarded as to protect workmen from coming into contact with same.

C. Outriggers shall be equal in strength to 6-inch steel I-beams and shall be securely anchored to the frame of the building by means of U-bolts and anchor plates tightened by the use of jam or lock nuts, or by other approved equally effective means. Outriggers shall extend at least 12 inches beyond the outside edge of scaffold platform.

D. I-beam outriggers shall be equipped with a stop bolt of adequate size to prevent the shackle from slipping over the outside end of the beam.

E. Cables on all suspended scaffolds shall possess factors of safety of at least eight (8). A metal tag shall be placed on all cables at a point readily accessible to inspection, showing the size and material of the cable, including the maximum safe load and date of renewal.

F. Proper methods shall be used in pouring sockets and only zinc shall be used. When thimbles and clamps are used, not less than three clips shall be used at each fastening.

G. Splicing anywhere throughout the length of the cable is prohibited. Where riding of the cable on the drum occurs, it shall be adjusted immediately by someone experienced in such work.

H. Putlogs shall be securely fastened to the scaffold fixtures and spaced not more than 8 feet apart.

I. Platform planks shall be laid so that their edges abut and fit tight. Planks shall be not less than 2 by 10 inches.

J. Platform planks shall overlap putlogs by at least 1 foot but not more than 2 feet at the ends of the scaffold.

K. All suspended scaffolds shall be tied in such a manner as to prevent the scaffold from swaying or swinging away from the building.

L. Where work is being performed overhead, an overhead protective covering shall be provided on all suspended scaffolds at a height not more than 9 feet above the working platform.

SECTION 18—NEEDLE BEAM SCAFFOLDS

8305.18

A. All needle beams shall be plainly marked so as to provide against being used for any other purpose.

B. Wood needle beams up to 12 feet length shall be at least 4 by 6 inch spruce or other approved lumber of equal strength, and shall be free from knots or other imperfections. For longer spans or heavier loads, the cross section shall be proportionately increased.

C. All needle beams shall be at least 2 feet longer than the distance between the supports, and shall be one solid piece without splicing. Provision shall be made to prevent the supporting ropes from slipping over the ends of the beam.

D. Pipe needle beams shall be of one piece wrought iron or steel pipe free from rust or scale.

E. When the scaffold span is not more than 12 feet, the pipe shall be at least $3\frac{1}{2}$ inches in diameter. For longer spans or heavier loads the diameter of the pipe shall be proportionately increased.

F. Where the space between needle beams is 12 feet or less, the platform shall be composed of planks at least 10 inches wide and 2 inches thick. Where the span is over 12 feet, the cross section of the planks shall be increased in proportion.

G. Platforms in the interior of a building shall be not less than 2 feet 6 inches wide; on the outside not less than 3 feet 6 inches wide.

H. All planks shall be secured by suitable cleats or drop bolts to prevent them from slipping, tipping, or collapsing. Where the planks are to be used in a steeply inclined position, they shall be provided with cleats at least $1\frac{1}{4}$ by 2 inches in cross section, spaced not more than 8 inches apart.

I. The ropes shall be attached to the needle beams by a scaffold hitch or some other equally effective method. All ropes shall be so secured to the beams or girders as to prevent slipping or tipping of scaffold.

J. The rope shall be at least 1 inch in diameter, and shall be increased in proportion to the size of the load. The supporting rope shall not be attached to the needle beam at a point less than 1 foot from the end of the beam.

SECTION 19—FLOAT OR SHIP SCAFFOLDS

8305.19

A. Scaffolds of this type shall be used only for the support of men doing riveting or other light work. Not more than two (2) men shall work on such a scaffold and it shall not be used for the storage of materials.

B. Planks for platforms and bearers shall be in one length. No spliced material shall be used.

C. Platforms shall be not more than five (5) feet wide and eight (8) feet long, but preferably should be not more than four (4) feet wide and seven (7) feet long.

D. The supporting plank bearers shall be of not less than two by eight (2 x 8) inch lumber and should project not less than six (6) inches beyond the platform on both sides. An additional diagonal plank of not less than one by six (1 x 6) inch lumber shall extend from bearer to bearer underneath the platform and each platform plank shall be nailed to this diagonal board and to the two (2) parallel plank bearers.

E. The platform shall be of not less than two (2) inch planking lumber.

F. Ends of platform planks shall extend at least six (6) inches beyond the outer edges of the bearers.

G. Ropes shall be of the best quality Manila fiber, of a size sufficient to support the suspended load with a safety factor of not less than four (4), but in no case smaller than seven-eighths ($\frac{7}{8}$) inch in diameter. If substitute material must be used, it shall be of a size to provide strength equivalent to Manila rope.

H. The platform shall be supported by a continuous rope at each end, the ends of each rope being securely fastened to an adequate overhead support.

I. The scaffold platform shall be so secured to the suspending ropes that slipping is impossible. Each supporting rope shall pass downward through a one (1) inch hole in the bearer plank, be single-hitched around the bearer plank and pass along be-

neath it to the other end, where it shall again be single-hitched and pass upward through a similar hole to the overhead support.

J. The holes in the bearer planks as specified above shall be approximately two (2) inches outside the outer planks.

K. Every float scaffold shall be examined by the foreman in charge before being used and at regular intervals thereafter.

L. Railings and toeboards will not be required on float scaffolds.

SECTION 20—MANUFACTURED SCAFFOLDS 8305.20

A. All manufactured metal ladders and scaffolds shall be types approved by Underwriters' Laboratories, Inc.

B. All manufactured scaffolds shall be erected in accordance with the manufacturers' specifications.

LADDER SPECIFICATIONS

SECTION 01—GENERAL 8306.01

A. Construction ladders shall be provided and maintained in place during working hours until temporary or permanent stairways are ready for use.

B. Single rail ladders shall not be constructed for use except as provided for under "Roofing Devices."

C. Wood side rails shall be of thoroughly seasoned material free from shakes, cross grain, checks, and decay. Knots shall not exceed $\frac{1}{2}$ inch in diameter and shall not be nearer than $\frac{1}{2}$ inch to the edge of the rail or 3 inches of the rung.

D. Wood rungs shall be of thoroughly seasoned material free from knots, shakes, cross grain, large checks, or decay. They shall be of white oak, ash, or material equivalent thereto in strength and wear.

E. Wood rungs shall be inserted in holes in the side rails and in all cases securely fastened, with a uniform spacing between rungs, not to exceed 12 inches on centers.

F. Ladders with weakened, broken, or missing treads, rungs, or cleats or broken side rails shall not be used, and ladders which have developed defects shall be withdrawn from service. Cleats shall not be used to repair rung ladders.

G. Ladders when in place shall have a substantial bearing for all rails at the bottom and when inclined shall have a substantial support at or near the top.

H. Ladders placed where there is danger of slipping shall be secured by the use of cleats, metal points, safety shoes, lashing, or other effective means. Painted ladders will not be permitted. However, linseed oil or clear varnish may be used.

I. All ladders with spreading bases such as step and trestle ladders shall be equipped with rigid spreaders or other means to prevent their premature opening or closing.

J. Fixed ladder landings shall be equipped with standard guardrails and toeboards. Such platform shall be not less than 24 inches in width.

K. Rails of fixed ladders to landings shall extend a distance of at least 36 inches above the landing. The rungs may be omitted above the landing. Landing shall be provided where an employee must step a greater distance than 14 inches from ladder to roof, tank, etc.

L. The landing distance shall not be greater than the rung spacing of the ladder.

M. Portable ladders shall not be used with a pitch such that the horizontal distance from the wall to the foot of the ladder shall exceed one-fourth of the unsupported length of the ladder unless it is securely braced to prevent sagging.

N. Ladders not specifically mentioned herein shall be of sufficient strength to resist double the strain of the heaviest load that will be placed upon it in use.

O. Single ladders not constructed to be used as sectional ladders shall not be spliced together to form a longer ladder unless such splicing together shall provide and maintain the strength and rigidity required for ladder construction.

P. Ladders on which workers are employed when placed in passageways, doorways, driveways, or public thoroughfares shall be guarded by barricades (guardrails). Doors which open adjacent to where such work is being done on ladders shall be securely closed or fastened open while work is in progress. Working from ladders is not an acceptable practice and should not be countenanced except for minor operations. No one shall ascend or descend a ladder except by facing the rungs.

SECTION 02—SINGLE RUNG LADDERS

8306.02

A. Side rails and rungs shall have a minimum dressed cross section of the following dimensions:

Length	Rail sections	Rungs
Up to and including 16 feet	1 $\frac{1}{2}$ " x 2 $\frac{1}{2}$ "	1 $\frac{1}{8}$ "
Over 16 feet and up to and including 20 feet	1 $\frac{3}{4}$ " x 2 $\frac{3}{8}$ "	1 $\frac{1}{8}$ "
Over 20 feet and up to and including 24 feet	1 $\frac{3}{4}$ " x 2 $\frac{3}{4}$ "	1 $\frac{1}{8}$ "

B. Ladders with parallel side rails shall have a minimum inside width between rails of 12 inches.

C. Ladders with spread rails shall have a minimum inside width at top rung of 12 inches and at each succeeding rung $\frac{1}{4}$ inch wider.

D. Rungs shall not exceed 30 inches in length.

E. Tenons shall be $\frac{7}{8}$ inch in diameter.

F. Masons' single ladder up to 22 feet in length shall have side rail cross section of 1 $\frac{3}{8}$ by 4 inches and rungs spaced not more than 10 inches on centers.

G. High-grade manufactured ladders with curved side rails will be permitted.

SECTION 03—SINGLE CLEAT LADDERS

8306.03

A.

Length	Minimum inside width	Maximum inside width	Cross section of rails	Cross section of cleats
Up to 12'	20"	24"	2" x 4"	1" x 3"
More than 12' and up to 16'	20"	24"	2" x 4"	1" x 3"
More than 16' and up to 20'	20"	24"	2" x 6"	1" x 4"
More than 20' and up to 24'	20"	24"	2" x 6"	1" x 4"

The lumber dimensions given in the above table are trade sizes.

B. Fixed ladders shall follow dimensions given for single cleat ladders and may exceed 24 feet in height provided they are securely fixed or braced at intervals of not more than 15 feet.

SECTION 04—EXTENSION LADDERS

8306.04

A.

Length	Cross section of rails	Diameter rungs
Up to and including 32'-----	1 $\frac{3}{16}$ " x 2 $\frac{3}{4}$ "-----	1 $\frac{1}{8}$ "
More than 32' and up to 38'-----	1 $\frac{3}{16}$ " x 3"-----	1 $\frac{3}{8}$ "
More than 38' and up to 44'-----	1 $\frac{3}{8}$ " x 3 $\frac{1}{4}$ "-----	1 $\frac{3}{8}$ "

B. Each ladders shall be equipped with two automatic locks. Locks shall be of such construction as to make the extension ladder equal in strength to a ladder constructed of continuous side rails.

C. All parts of the lock shall be of malleable iron or other equivalent material.

D. All other iron parts of the ladder shall be of malleable or wrought iron or equivalent material.

E. Where pulleys are used the ladder shall be equipped with a galvanized malleable or wrought iron shackle and pulley.

F. The lumber dimensions given herein are minimum dressed.

G. Tenons shall be not less than $\frac{1}{8}$ inch in diameter.

H. Masons' extension ladder shall be limited to two sections and to 44 feet in length, shall have side rails 1 $\frac{3}{8}$ by 4 inches. Width of bottom section shall be not more than 20 inches; rungs not less than 1 $\frac{1}{4}$ inches in diameter and tenon 1 inch in diameter.

SECTION 05—STEPLADDERS

8306.5

A. Stepladders shall be limited to 20 feet in height. Higher stepladders may be used providing the sizes of construction members and bracing are increased so as to furnish the same factor of safety as provided herein.

B. Side rails dimensions up to and including 10 feet shall be $\frac{25}{32}$ by 2 $\frac{5}{8}$ inches. Back legs, $\frac{25}{32}$ by 1 $\frac{5}{8}$ inches.

C. Side rail dimensions for stepladders more than 10 feet and up to 20 feet shall be $\frac{25}{32}$ by 3 $\frac{1}{4}$ inches. Back legs, $\frac{25}{32}$ by 2 $\frac{1}{4}$ inches.

D. Step dimensions shall be $\frac{25}{32}$ by 3 $\frac{5}{8}$ inches, set into each side rail $\frac{1}{8}$ inch and supported by a $\frac{1}{4}$ -inch steel rod.

E. Bracing strips in backs shall be metal bound at ends. Material used in spreaders shall be equal in strength to $\frac{1}{8}$ -inch by $\frac{1}{2}$ -inch steel.

F. The lumber dimensions given herein are minimum dressed.

SECTION 06—SECTIONAL LADDERS

8306.06

A. The minimum dressed cross-section and distance between side rails of sectional ladders shall be as follows:

Sections	Side rails—cross section		
	Thickness (inches)	Depth (inches)	Distance (inches)
Up to and including 4 sections.....	1 $\frac{1}{8}$	2 $\frac{3}{4}$	13
Over 4 sections up to and including 6.....	1 $\frac{1}{2}$	3 $\frac{1}{4}$	20
Over 6 sections up to and including 10.....	1 $\frac{3}{4}$	3 $\frac{3}{4}$	24

B. If the length of sections exceeds 6 feet 4 inches the side rail cross sections shall be proportionately increased.

C. Rungs shall be 1 $\frac{1}{8}$ inches in diameter with $\frac{7}{8}$ -inch tenon.

D. The connection joint shall be not less than 1 foot. The grooved ends of the sections shall be reinforced with a metal plate not less than No. 18 U. S. Standard gage properly secured thereto and riveted above the groove extending through the depth of the rail or other equivalent fastening.

SECTION 07—TRESTLE LADDERS

8306.07

A. Sides for ladders up to 10 feet in length shall be 1 $\frac{5}{16}$ inches by 2 $\frac{3}{4}$ inches, minimum dressed. Rungs 1 $\frac{1}{8}$ inches in diameter shall be of oak, ash, or other wood of equal strength.

B. Longer ladders shall have side rails of proportionately larger dimensions.

C. Lumber shall be No. 1 clear spruce or other wood of equal strength.

D. Metal parts shall be malleable or wrought iron or metal of equivalent strength.

E. Rungs shall be rabbeted through the side and securely fastened thereto.

SECTION 08—EXTENSION TRESTLE LADDERS

8306.08

A. Sides of base for extension trestle ladders shall not be less than 1 $\frac{3}{8}$ inches by 2 $\frac{3}{4}$ inches, minimum dressed. Base section shall not exceed 16 feet in length.

B. Rungs of base and extension shall be 1 $\frac{3}{8}$ inches in diameter, of oak, ash, or other wood of equal strength, rabbeted through side rails and securely fastened thereto.

C. Sides of the extension section shall not be less than 1 $\frac{3}{8}$ inches by 2 $\frac{3}{8}$ inches and shall not exceed 16 feet in length.

D. Lumber for extension trestle ladders shall be No. 1 clear spruce or other wood of equal strength.

E. Metal parts shall be malleable or wrought iron or other metal of equivalent strength.

F. The locking device for securing the extension section to the base shall be of design as efficient as that specified for extension ladders.

PAINTING

SECTION 01—STORAGE OF PAINTS

8307.01

A. Packages containing paints, varnishes, lacquers, thinners, or other volatile painting materials shall be kept tightly closed when not in actual use, and shall be stored in well ventilated places where they will not be exposed to excessive heat, smoke, sparks, flame, or direct rays of the sun.

SECTION 02—SPRAY PAINTING

8307.02

A. Spray painting in enclosed places with materials containing lead, benzol or any ingredient injurious to health shall be segregated from other employees by a temporary partition of canvas or other suitable material. If lights, switches and live electric wiring are necessary they shall be of the explosion proof type.

B. No smoking or open fire of any kind shall be permitted in rooms where spray guns are in operation.

ELECTRICAL WIRE AND APPARATUS

SECTION 01—GENERAL

8308.01

A. Electric wiring in temporary or permanent use shall be installed and maintained, by competent and qualified workmen, so as to effectively protect all persons against injury therefrom.

B. Substantial insulation, grounds, or other protection shall be provided during construction operations to protect employees from injuries resulting from temporary or permanent electric wiring or apparatus.

C. Extension cords to lights and electrically operated tools or devices, together with their connections and fittings shall be insulated and maintained in a safe condition. Wires carrying electrical current shall not be run on the ground unless effectively insulated.

D. Wiring equipment such as fastenings, connections, etc., where accessible to workmen shall be nonconductive and/or where conductive equipment is used the same shall be guarded so as to protect workmen against injury.

E. No work shall be done on any wiring or equipment carrying 600 volts or over until the portion being worked upon is protected on both sides by grounds, blocks, bypasses, hold-off systems or by other effective means.

F. All work on electric wiring and equipment carrying 600 volts or more, shall be performed by men competent and qualified in high voltage installations.

G. Suitable insulating mats or platforms of substantial construction and providing good footing shall be so placed on floors and, if necessary, on the frames of the machines having exposed live parts of more than 150 volts to a ground, that the operator or persons in the vicinity cannot readily touch such parts unless standing on the mats, platforms, or insulating floors.

H. Overloading of electric circuits is prohibited.

I. All circuits shall be fused or have circuit breakers adjusted for the designated safe load.

J. The use of slugs or jumpers on circuit breaking devices is prohibited.

K. When temporary wiring is used in tanks, cofferdams or other confined spaces, an approved type switch shall be provided at the entrance to such spaces for cutting off the current in emergencies.

BLASTING

SECTION 01—GENERAL

8309.01

A. The transportation, handling, storage and use of dynamite and other explosives shall be directed and supervised by a person of proven experience and ability in blasting operations. These operations shall be in accordance with the following requirements:

1. All blasts must be fired with an electric blasting machine.

2. When detonating fuse is used, it shall be fired by the use of an electric blasting cap.

B. Blasting machines must be known to be in good condition and of sufficient capacity to fire all charges. For blasting machines the following performance rating shall apply:

1. The machines shall fire without failure at least five times in succession, two electric blasting caps in series, through resistance as follows:

75 Ohms for 10 cap machines.

144 Ohms for 30 cap machines.

208 Ohms for 50 cap machines.

320 Ohms for 100 cap machines.

C. Rubber covered or other adequately insulated copper wires in good condition shall be used for firing lines and shall have solid cores. Sufficient firing line shall be provided to permit the blaster and other workers to be located at a safe distance from the blast. Single conductor lead lines shall be used.

SECTION 02—TRANSPORTATION OF EXPLOSIVES 8309.02

A. Trucks used for the transportation of explosives must not be loaded beyond rated capacity and the boxes of explosives must be so secured that they cannot drop off the truck. In all open body types of vehicles the explosives must be covered with a fire resistant tarpaulin.

B. All trucks used for the transportation of explosives shall be marked or placarded on both sides and ends with the word "Explosives" in letters not less than 3 inches high or shall conspicuously display a red flag not less than 24 inches square, marked with the word "Danger" in white letters not less than 6 inches high.

C. Electric blasting caps shall not be transported in the same vehicle with other explosives.

D. All trucks shall be in the charge of and operated by a person who is physically fit, careful, reliable, able to read and write the English language and not addicted to the use of intoxicants or narcotics. No person under the influence of intoxicants or narcotics will be permitted to transport, handle, or otherwise use explosives.

E. No metal, metal tools, carbides, oils, matches, firearms, electric storage batteries, inflammable substances, acids, oxidizing or corrosive compounds shall be carried in the bed or body of any motortruck and/or vehicle transporting explosives.

F. Trucks to be used in the transportation of explosives must be clean and in good repair. When steel or part-steel bodies are used, canvas or other relatively nonflammable cushioning materials must be employed to separate the explosives from the metal.

G. Trucks shall be equipped with not less than two fire extinguishers, placed at convenient points, filled and ready for immediate use, and of a make approved by the National Board of Fire Underwriters.

H. A truck containing explosives shall never be taken into a garage or repair shop or parked in congested areas or stored over night, or at any other time, in a public garage or similar building.

I. All trucks shall be checked before transporting explosives and all electric wiring completely protected and securely fastened to prevent short circuiting.

J. Trucks transporting explosives shall be operated with extreme care and shall not be driven at a speed greater than 25 miles per hour. Full stops shall be made at approaches to all railroad crossings and main highways and the truck must not proceed until it is known that the way is clear.

K. Explosives shall not be transported in any form of trailer, nor shall any trailer be attached to a motortruck or vehicle hauling explosives.

L. No person other than the authorized driver and helper shall be permitted to ride on trucks transporting explosives or detonators.

M. Explosives shall not be transported during hours of darkness except in extreme emergency and only when the written approval of the area engineer has been secured.

N. The gasoline tank of a motortruck shall not be filled while explosives are on the motortruck except in emergency and then only when the engine of the motortruck is stopped.

O. Explosives unloaded from trucks shall be piled at sufficient distance from exhaust to prevent danger of sparks igniting the explosives.

P. Persons employed in the transportation, handling, or other use of explosives shall not carry on their person or in the truck, matches, firearms, ammunition, or other flame producing devices.

SECTION 03—HANDLING OF EXPLOSIVES

8309.03

A. Containers of explosives shall be opened only by means of wooden wedges and wooden mallets. The dropping of loaded containers for the purpose of opening the same is prohibited.

B. Dynamite cartridges shall only be removed from containers as they are needed for immediate use and carried to the blasting area in nonmetallic containers.

C. Explosives and detonators shall be taken to the blasting area in separate nonmetallic containers, except that primers prepared at a central priming station may be carried in a non-metallic container.

D. After loading of a blast is completed, all excess explosives and detonators shall be returned at once to the storage magazine, observing the same rules as when being conveyed to the blasting area.

E. All empty dynamite boxes showing stains of any kind shall be destroyed by burning out of doors at a safe distance from magazine and other structures.

SECTION 04—STORAGE OF EXPLOSIVES

8309.04

A. Separate magazines shall be provided for storage of explosives and detonators. Such magazines shall be bulletproof, fire-resistant and weather proof and of an approved type and shall be adequately ventilated. The minimum distance between magazines storing detonators and explosives shall be 100 feet unbarricaded or 50 feet barricaded.

B. The area around the magazine for a distance of 25 feet shall be kept clear of vegetation and all combustible matter.

C. The magazines shall not be unlocked except for inspection and the storage and removal of explosives; and the key shall be in the charge of a reliable and competent person who shall be in charge of explosives and the magazines.

D. Shoes with nails or metal plates which are likely to cause friction sparks shall not be worn in magazines.

E. Magazines in which explosives are stored shall not be used for any other purpose. No metal tools of any description shall be kept in magazines.

F. Explosives shall be arranged in the magazine so that oldest stock is used first.

G. Repairs to inside of magazines shall not be made without first removing all explosives to a safe distance and providing them with ample protection.

H. Explosives shall be stored only in original containers.

I. Explosives shall be stored with top side up.

J. Magazines shall be kept dry and clean, and the area around the magazine posted with appropriate "Caution" or "Danger" signs.

K. Magazine floors shall continually be kept clean.

L. Explosives containers shall be opened, packed or repacked only at a distance of at least 50 feet from any magazine.

M. No smoking, matches, firearms, open flames, or any flame producing device, shall be permitted within 100 feet of any magazine.

N. Magazine floors that become stained with nitro-glycerin shall be scrubbed with a stiff broom or brush using a freshly made solution composed of $\frac{1}{2}$ gallon of water, $\frac{1}{2}$ gallon of wood alcohol and 2 pounds of sulphide of sodium. Plenty of the liquid should be used so as to thoroughly decompose the nitro-glycerin.

O. Detonators shall not be taken into a magazine containing other explosives.

P. Opened boxes of explosives shall not be left in a magazine.

Q. All magazines in which explosives are had, kept, or stored shall be located at the distance from buildings, railroads, and highways in conformance with the following table:

American table of distances

Quantity that may be had, kept or stored				Distance (feet) from nearest—		
Electric blasting caps		Dynamite		Build- ing	Rail- way	High- way
Number over	Number not over	Pounds over	Pounds not over			
1,000	5,000	-----	-----	30	20	10
5,000	10,000	-----	-----	60	40	20
10,000	20,000	-----	-----	120	70	35
20,000	25,000	-----	50	145	90	45
25,000	50,000	50	100	240	145	70
50,000	100,000	100	200	360	225	110
100,000	150,000	200	300	520	310	150
150,000	200,000	300	400	640	380	190
200,000	250,000	400	500	720	430	220
250,000	300,000	500	600	800	480	240
300,000	350,000	600	700	860	520	260
350,000	400,000	700	800	920	550	280
400,000	450,000	800	900	980	590	300
450,000	500,000	900	1,000	1,020	610	310
500,000	750,000	1,000	1,500	1,060	640	320
750,000	1,000,000	1,500	2,000	1,200	720	360
1,000,000	1,500,000	2,000	3,000	1,300	780	390
1,500,000	2,000,000	3,000	4,000	1,420	850	420
2,000,000	2,500,000	4,000	5,000	1,500	900	450
2,500,000	3,000,000	5,000	6,000	1,560	940	470
3,000,000	3,500,000	6,000	7,000	1,610	970	490
3,500,000	4,000,000	7,000	8,000	1,660	1,000	500
4,000,000	4,500,000	8,000	9,000	1,700	1,020	510
4,500,000	5,000,000	9,000	10,000	1,740	1,040	520
5,000,000	7,500,000	10,000	15,000	1,780	1,070	530

NOTE.—For larger quantities see the complete American Table of Distance.

A 50 percent reduction in the above distances may be applied in connection with magazines that are screened from buildings, railroads, highways, or other magazines either by natural features of the ground or by an efficient artificial barricade of such height that any straight line drawn from the top of any sidewall of the magazine to any part of the building to be protected will pass through such intervening natural or efficient artificial barricade, and any straight line drawn from the top of any sidewall of the magazine, to any point 12 feet above the center of the railroad or highway to be protected, will pass through such intervening natural or efficient artificial barricade.

R. Magazines in which more than 50 pounds of explosives are stored shall be detached from other structures, and magazines where more than 5,000 pounds of explosives are stored shall be located at least 200 feet from any other magazine, except blasting cap magazines. Magazines where quantities of explosives in excess of 25,000 pounds are kept and stored shall have an increase over 200 feet of $2\frac{2}{3}$ feet for each 1,000 pounds of explosives in excess of 25,000 pounds stored therein. These distances between magazines may be disregarded where the total quantity stored in the several magazines complies with the American Table of Distance as regards proximity to inhabited buildings, railways, and highways—except that in all cases, the quantity of explosives contained in blasting-cap magazines shall govern in regard to spacing said cap magazines from magazines containing other explosives, but under no circumstances shall a magazine containing blasting caps be within a less distance than 100 feet not barricaded, or 50 feet barricaded from any magazine other than cap magazine.

S. Leaking or deteriorated dynamite shall be disposed of in accordance with manufacturer's instructions.

SECTION 05—DRILLING

8309.05

A. All drill holes shall be of greater diameter than the diameter of cartridges of explosives used. Loading and drilling shall not be carried out at the same time in the same area.

B. Drilling shall not be started until all remaining butts of old holes are examined for unexploded charges. Never insert a drill, pick, or bar in such holes even if examination fails to disclose explosives.

C. Drilling shall not be resumed after blasts have been fired until a thorough examination has been made to make sure that there are no unexploded charges remaining.

SECTION 06—LOADING

8309.06

A. In loading small diameter bore holes, tamping shall be done with a wooden stick having no metal parts. Primed cartridges shall be seated by even steady pressure only.

B. All loaded holes or charges shall be checked and definitely located before firing.

C. When holes are sprung, leave ample time between springing shots for the hole to cool, and also between the last springing shot and the loading of the main charge.

D. No more cartridges shall be primed than are required for a single round of blasting. Detonators shall only be inserted in a hole in the end of a cartridge prepared especially for that purpose. Holes shall be made with a sharpened wooden stick.

E. All charges shall be covered with blasting mats before firing, where blasting is done in the vicinity of structures likely to be injured by flying rock.

SECTION 07—WIRING

8309.07

A. Each electric blasting cap shall be tested with an approved galvanometer before and after tamping a hole.

B. All caps in a blast shall have copper wire and shall be of the same manufacture.

C. After testing the leg wires of electric blasting caps, they shall be short-circuited by twisting the bare ends together and shall remain so twisted until ready to be connected into the circuit preparatory to connecting to the firing line.

D. All electric blasting caps shall be wired in series and the firing line shall not be smaller than No. 14 B and S gage copper wire.

E. The number of electric blasting caps fired in one series shall not exceed the rated capacity of the blasting machine.

F. The circuit including all caps should be tested with an approved galvanometer before being connected to firing line.

G. The complete circuit, lead wires and firing line, should be checked with an approved galvanometer at the terminals to be hooked on to blasting machine.

H. No firing line shall be connected to a blasting machine until just before the shot is to be fired.

I. Cartridges shall not be primed nor holes loaded during approach of a thunderstorm or while it is in progress. If a charge has been primed or holes loaded, every person shall be ordered to a safe distance until the storm is over.

SECTION 08—FIRING

8309.08

A. Prior to the firing of a shot, all persons in the blasting area shall be warned of the blast and ordered to a safe distance from the area. Blast shall not be fired until it is *absolutely certain that every person* has retreated to a safe distance and that no one remains in a dangerous location.

SECTION 09—INSPECTION AFTER BLASTING 8309.09

A. Immediately after blast has been fired, the firing line shall be disconnected from the blasting machine and carried back at least half the distance from the blasting machine to the area of the blast.

B. The firing line shall be left in this position until all inspection and checking work has been completed.

C. After the blast has been fired, a minute inspection shall be made to determine if all charges have been exploded before any person is allowed to return to the area of the blast.

D. All wires shall be carefully traced and search made for unexploded cartridges.

SECTION 10—MISFIRES

8309.10

A. If broken wires, faulty connections, or short circuits are determined as the cause of a misfire, the proper repairs shall be made, the firing line reconnected, and the charge fired. This shall be done, however, only after a careful inspection has been made of burdens remaining in such holes and no hole shall be so refired when the burden has been dangerously weakened by other shots.

B. Misfired charges tamped with solid material shall be blasted out by the process of detonation by concussion. In using this method a new hole shall be drilled and fired at a point no nearer than two feet from the misfired charge. In following this procedure a careful search shall be made for unexploded material in the debris of the second charge.

FIRE PREVENTION AND PROTECTION**SECTION 01—FIRE PREVENTION**

8310.01

A. All construction areas and storage yards shall be burned over or otherwise cleared before lumber or other combustible materials are delivered on the site. A clear space of one hundred (100) feet around the site of storage yards will be included

in the cleared area. This does not apply to trees and other natural cover retained for military purposes. Clearing operations shall be controlled in order to prevent damage to existing trees and other vegetation which are not part of the site being cleared.

B. Separation of temporary buildings :

1. The minimum space between one-story frame buildings will be forty (40) feet.
2. The minimum space between two-story frame buildings will be fifty (50) feet.
3. A group of buildings, the aggregate ground floor area of which does not exceed 2,000 square feet, will be considered as one building for the above purpose.

C. Lumber storage yards will be divided into sections containing a maximum of seven hundred fifty thousand (750,000) feet B. M. with fire breaks of one hundred (100) feet between sections. Lumber storage will be maintained at a minimum distance of one hundred (100) feet from buildings or structures. No lumber, refuse or vehicles will be left in these spaces after working hours. Parking of vehicles in fire breaks will not be permitted.

D. At least ten (10) feet clearance from buildings or structures will be maintained for piles of lumber and other materials to be used in the construction.

E. The following materials will be stored separately in detached weatherproof buildings or shelters ; acids, unslaked lime, carbide, oakum, hay and straw.

F. Storage, handling, installation and use of liquefied petroleum gases and systems will be in accordance with current standards of the National Board of Fire Underwriters for Liquefied Petroleum Gases.

G. No fires, welding, cutting, melting and other such hazardous operations shall be permitted on a project until permission has been obtained from the resident engineer or his authorized representative. Fires, open flame devices, burning, welding, cutting, or other such operations in close proximity to combustible materials, shall not be left unattended. While danger of fire exists, an approved type fire extinguisher shall be provided at the immediate location.

H. Lanterns, acetylene lights or other open flame lighting devices will not be used in stables, garages or buildings housing

flammable liquids or hay, straw, or other combustible fibrous material.

I. Lamps and lanterns will be filled only in well-ventilated rooms free from open flames, and will not be filled in oil storage buildings.

J. Temporary high voltage wires shall not be run above buildings or storage piles of combustible materials.

K. Salamanders when in use should be kept at least two feet horizontally and six feet vertically from combustible material. When used in an area inclosed by tarpaulins, they should be kept at least 10 feet from tarpaulins. Salamanders should be under constant supervision when in use.

L. All fabric or paper coverings used on storage of combustible materials or as inclosures on buildings or structures shall be flameproofed.

M. Smoking shall be prohibited in all areas where combustible materials are stored, warehouses, carpenter, paint, and repair shops, garages, service stations, and other such hazardous areas, except at locations specifically provided for such purpose and approved by the resident engineer. "No Smoking" signs shall be posted in all prohibited areas.

N. All rubbish will be cleared from buildings daily and work areas will be maintained free from accumulations of combustible debris.

O. Ashes will be regularly removed, will be deposited only in incombustible containers, and will be kept at least 2 feet from combustible walls, partitions or material.

P. Areas beneath buildings will not be used for storage of combustible material and will be regularly policed to keep them free from accumulation of debris.

SECTION 02—FIRE PROTECTION

8310.02

A. Adequate water supply shall be provided for fire fighting facilities.

B. When construction operations are suspended, a watchman shall be employed who will make hourly rounds through areas where buildings are in place and where combustible materials are stored.

C. A first-aid fire fighting device shall be provided not more than one hundred (100) feet from any point where combustible materials are stored, used or in place in buildings or structures. This device shall consist of the following:

1. For Class "A" Fires—Fires in ordinary combustible materials where the quenching and cooling effects of quantities of water or solutions containing large percentages of water are of first importance.

Soda and acid, pump tank extinguishers or water barrels and buckets.

2. For Class "B" Fires—Fires in flammable liquids, greases, etc. where blanketing effect is essential.

Foam, carbon tetrachloride, CO₂, dry powder pressure type extinguishers, sand buckets and scoops.

3. For Class "C" Fires—Fires in electrical equipment where the use of non-conducting extinguishing agent is of first importance.

Carbon tetrachloride, CO₂, dry powder pressure type extinguishers.

D. All storehouses, shops, service stations, transformer stations and other such locations shall have at least one approved type extinguisher. For floor areas exceeding twenty-five hundred (2500) square feet, at least one extinguisher shall be provided for each twenty-five hundred (2500) square feet of floor area.

E. All extinguishers and other fire fighting equipment shall be inspected, serviced and maintained in accordance with the manufacturers' instructions. Fire barrels and buckets shall be painted red, marked "Fire Only" and kept filled at all times. Anti-freeze protection shall be provided when necessary.

F. When the value of combustible materials stored or used on the site or in place in buildings or structures exceeds \$150,000, a sufficient number of mobile pumping units shall be provided and so located that no point where combustible materials are stored, used or in place in buildings or structures shall be more than three (3) miles from such a unit.

1. Mobile pumping units shall have a rated capacity of fifty (50) G. P. M. at one hundred and twenty (120) pounds pressure and a tank of not less than five hundred (500) gallons capacity which shall be kept full at all times. Pumps shall be equipped with five hundred (500) feet of one and one-half inch hose and one-half ($\frac{1}{2}$) inch shut off nozzle. Fifty (50) feet of suction hose with a strainer shall be provided.

2. Operators qualified to operate each mobile pumping unit shall be available twenty-four hours a day during the period of construction.
3. Names, badge number and hours of duty of fire truck operators shall be submitted to the resident engineer.

When an agreement to respond to fire alarms has been effected between a local, municipal or post fire department, located within three (3) miles of the project, such arrangement when approved by the resident engineer will be accepted in lieu of the requirement of this paragraph.

G. A necessary number of project employees shall be trained and organized into a fire brigade.

H. In the event that water tank trucks are used on the projects, they shall report to the scene of a fire in emergencies. Suitable connections shall be provided on all water tank trucks for emergency fire services.

I. Vehicles, equipment, materials and supplies will not be placed in such a manner as will obstruct access to fire hydrants, fire extinguishers or other fire fighting equipment.

J. Fire lanes to provide access to all areas will be established as construction progresses and will be maintained free of obstruction from parked vehicles and materials.

K. No fire protection equipment or device shall be made inoperative or used for other purposes.

L. A siren, telephone system or other suitable alarm arrangement shall be provided on all projects subject to approval of the resident engineer.

M. When unusual fire hazards exist or emergencies develop, additional fire protection may be required by the resident engineer.

CLEARING OPERATIONS

SECTION 01—GENERAL

8312.01

A. All tools and equipment on clearing operations shall be inspected by a supervisor before being placed in service and daily thereafter. Defective tools and equipment shall be taken out of service, replaced or repaired and re-inspected before being returned to service. Tools and equipment shall be repaired and maintained by qualified mechanics.

B. Approved personal protective equipment or apparel shall be furnished workers for protection against eye, head, leg or

foot injuries, for those working water or swampy areas and on ice or other hazardous surfaces.

C. No person, vehicle or equipment shall be permitted on frozen rivers or lakes until the ice has been checked, dangerous spots properly marked and such operations approved by the superintendent. Foot paths across frozen rivers or ponds shall have life lines installed, and sanded if practical.

D. Sharp edge tools shall be transported in carrying cases or sheaths.

E. Machetes shall be kept in sheaths at all times except when in actual use.

F. Bulldozers shall be equipped with suitable shields or guards which will protect operators from falling or flying trees, limbs, broken cables and similar hazards.

G. Bulldozers shall be provided with crankcase guards and radiator protection.

H. All persons shall be required to stand clear of moving machines, equipment or moving logs, and lines when under strain.

I. A qualified signalman shall be designated to signal all drivers and operators of teams, tractors or equipment used in clearing. A standard set of signals shall be used.

J. No team, tractor or other hauling equipment shall be placed in motion until everyone is in the clear and appropriate signal has been given by designated signalman.

K. Skid poles shall be so secured as to prevent sliding or kicking.

L. All "A" frames, spars, and similar equipment shall be securely guyed or braced to prevent tipping or falling.

SECTION 02—FELLING—BUCKING

8312.02

A. All underbrush, vines, small trees, etc., that will interfere with felling operations shall be cleared before felling begins.

B. Before felling, all trees shall be inspected for rotten heart, dead or entangling limbs or similar hazardous conditions. Dead or entangling limbs which endanger employees shall be removed.

C. Trees which present an unusual hazard, such as those with rotten heart, dead, hollow, leaning, lodged or multiple growths, shall be felled under the direction of the supervisor.

D. All trees shall be properly undercut before felling and wedges shall be used to throw all balanced trees.

E. A warning call "T I M B E R" shall be given in sufficient time to permit all persons to get in the clear of falling trees.

F. Secure footing and a clear path of getaway shall be available before starting to fell a tree.

G. All fellers shall be required to retreat a safe distance from the path of falling trees.

H. When there is danger of damaging adjacent property in felling a trees, suitable tackle shall be used to control the fall.

I. After starting to fell a tree, that tree must be safely on the ground before leaving or going to the next tree.

J. Climbing trees while carrying unguarded sharp edged tools is prohibited.

K. Axes, brushhooks, saws and similar tools shall be kept out of the path of workmen.

L. Working in or on trees during high winds is prohibited.

M. Warning signs or flags shall be displayed in hazardous areas.

N. All men climbing or working in trees shall be required to use safety ropes, belts or slings.

O. All fallen trees held off the ground by their own branches or other obstructions and trees or logs on hillsides shall be chocked or propped before bucking or trimming is started.

P. Kneeling in hazardous locations while felling or bucking trees is prohibited.

Q. When using chain saws the chain shall not be started until the saw is in cutting position.

R. All persons shall be required to stand beyond the ends of the saw when chain is in motion. Chain saws shall be equipped with suitable guards at the back of the saw.

S. Operators shall be required to shut off saws and retreat a safe distance when tree starts to fall.

T. Chain saws shall not be used on rotten heart or hollow trees.

SECTION 03—DECKING AND BURNING

8312.03

A. Burning operations shall be kept under strict control and not left unattended.

B. Firing, punching and placing of material for burning shall be done from the windward side.

C. Use of flammable fluids on decks which are burning or smoldering is prohibited.

D. At every location where burning operations are taking place at least two 5-gallon pump tank extinguishers or equivalent protection shall be provided.

E. Decking methods which require use of a top decker shall not be permitted.

FLAMMABLES

SECTION 01—GENERAL

8313.01

A. All storage, handling or use of flammables shall be under the supervision of qualified persons. No one shall be permitted to handle or use flammables until he has been instructed in the safe handling and use of same.

B. A monthly inspection shall be made of all systems and equipment used for the storage, handling or processing of flammables.

C. All sources of ignition shall be prohibited in areas where flammables are stored, handled and processed. Suitable warning and "No Smoking" signs shall be posted in all such areas.

D. Rubbish, brush, long grass, or other combustible material shall be continually removed from immediate areas where flammables are stored, handled or processed.

E. All spills of inflammable liquids shall be cleaned up immediately.

F. All flammables, including intrastate shipments, shall be in containers approved for shipment of such materials by, and tagged or labeled in accordance with regulations of I. C. C.

G. All tanks, containers and pumping equipment, portable or stationary, used for the storage or handling of flammables shall meet the requirements of the National Board of Fire Underwriters.

H. Electrical lighting shall be the only means used for illumination in areas where flammable liquids, vapors, fumes, dusts or gases are present. All electrical equipment and installations shall be in accordance with provisions of the National Electrical Safety Code for hazardous locations. Globes of the vapor proof type shall not be removed or lamps replaced until it is certain that the circuit is dead.

I. Flashlights and electric lanterns used in connection with the handling of flammables shall be the type approved by the Underwriters' Laboratories, Inc.

J. Heating systems in buildings where flammables are

stored or processed shall be installed in accordance with regulations of the National Board of Fire Underwriters.

K. All buildings, rooms and compartments where flammables are present shall be properly ventilated. Where mechanical ventilation or exhaust systems are necessary, they shall be installed in accordance with regulations for installation of blower and exhaust systems by the National Board of Fire Underwriters.

L. Approved type fire extinguishers shall be provided at all locations where flammables are stored, processed or used.

M. No person shall be permitted to enter a storage tank, tank car or other vessel which has contained flammables until such vessel has been properly purged and ventilated. After purging and venting a test shall be made for gas. If the vessel is not gas free, purging and venting shall be repeated.

N. All persons entering storage tanks, tank cars, or other vessels which have contained flammable fluids or gases shall be provided with necessary protective clothing, approved air fed masks, safety belts, and life lines. An attendant shall be stationed at the entrance to such tank or vessel.

O. No welding, cutting, riveting, or other hot work and no mechanical repairs shall be performed on a storage tank, tank car or other vessel which has contained flammables until such vessel has been properly purged and ventilated. After purging and venting a test shall be made for gas. If the vessel is not gas free, purging and venting shall be repeated. Tanks or other containers brought to the shop for repair shall be purged and vented outside of buildings and well away from open flames and other sources of ignition.

P. Welding, riveting, or other hot work on tanks or containers which have contained flammable liquids or gases shall be performed only by men experienced in such work.

Q. All tools used in explosive atmospheres shall be of the non-sparking variety.

R. Woolen or asbestos fire blankets shall be provided and kept in conspicuous and easily accessible locations where substantial quantities of flammables are stored, handled and used.

SECTION 02—STORAGE

8313.02

A. Storage of flammable liquids shall be in accordance with the regulations of the National Board of Fire Underwriters.

B. Storage tanks and systems shall be electrically bonded and grounded in an approved manner.

C. All storage tanks shall be equipped with proper relief vents. Tank vents shall not be located close to open flames, stacks, heating apparatus or any other source of ignition. Vent screens shall not be painted. In freezing weather all vacuum and pressure reliefs shall be inspected daily.

D. Water draw-off valves shall be insulated to prevent freezing.

E. All storage tanks above ground shall be diked, curbed, or other suitable means provided to prevent the spread of liquids to other property in case of a rupture in tank or piping. Such dike or curbed area shall have a capacity equal in volume to that of the tank.

F. Outlets from storage tanks above ground shall be equipped with quick-closing valves.

G. Inside storage of large quantities of flammable liquids or gases in drums or other containers shall be in a separate fire resistant building located at least 50 feet from adjoining buildings or structures.

H. Entrances to storage or process buildings shall be kept under lock and key. Only authorized persons shall be permitted to enter such buildings.

I. A ventilated metal cabinet shall be provided for the storage of more than a total of 10 gallons of oils, varnishes, lacquers or other flammable liquids in buildings used for other than storage or processing. Not more than a total of 50 gallons shall be stored in any one cabinet. No individual container shall exceed five gallons capacity.

SECTION 03—HANDLING AND USE

8313.03

A. All dispensing of flammable fluids shall be by approved pumping arrangement from underground tanks or tank trucks. This rule applies to containers of over 55-gallon capacity. Use of pumping arrangement is recommended in all cases.

B. The handling of flammable fluids in open containers is prohibited.

C. Tank cars or trucks shall be spotted accurately, and not loaded or unloaded until brakes have been set and wheels chocked.

D. Blue flag warning signs shall be clamped to the rails to warn train crews when tank cars are connected.

E. Tank cars or trucks shall never be left unattended while being loaded or unloaded.

F. All tank cars and trucks shall be properly bonded and grounded while being loaded or unloaded. Bonding and grounding connections shall be made before dome covers are removed on cars and trucks and shall not be disconnected until such covers have been replaced. Internal vapor pressure shall be relieved before dome covers are opened.

G. All processing and mixing of flammable liquids shall be in separate fire resistant building except that in buildings of type A fire resistant construction such operations shall be permitted in separate rooms cut off from the rest of the building by 8-inch concrete or brick walls. Approved type fire doors shall be provided on such rooms. Entrances to all processing or mixing rooms shall be provided with a noncombustible sill raised 6 inches.

H. Floors in all process and mixing rooms shall be fire resistant and drainage provided to a safe location.

I. Not more than 1 day's supply of flammable fluids shall be kept in any processing or mixing room. If 1 day's requirements are less than 55 gallons, not more than 1 drum shall be permitted.

J. Accumulations of flammable materials on floors, walls, etc., shall not be permitted.

K. Bungs, caps, or stoppers shall not be left out of drums, barrels, or other flammable liquid containers. This rule also applies to empty containers.

L. All tanks, hoses, and containers shall be kept in metallic contact while flammable liquids are being poured.

POISONOUS AND HARMFUL SUBSTANCES

SECTION 01—GENERAL

8314.01

A. All dusts, mists, fumes, gases or other atmospheric impurities generated in connection with an operation or process, emitted into or disseminated throughout areas where persons are employed, in such quantities as are determined to be harmful to the health of such employees, shall be controlled by one or more of the following methods:

1. Inclosure of such process or operation.
2. Isolation or rearrangement of such process or operation.
3. Substitution of non-toxic material.

4. Wet methods.
5. Dilution by general ventilation.
6. Local exhaust ventilation.
7. Temperature control.

Where the above methods are impractical, air line respirators shall be provided for continued exposure.

B. For intermittent or casual exposures, chemical cartridge or filter type respirators approved by the U. S. Bureau of Mines may be used.

C. All persons required to use respirators or other protective equipment shall be properly instructed in the use of such equipment.

D. When required by the resident engineer, the contractor shall have determinations made of the kind and amount of atmospheric impurities from samples taken at a point or points in the breathing zone of workers during normal operations. These determinations shall be made by a properly qualified analyst.

E. Concentrations of materials which equal or exceed the following shall be considered harmful exposures or concentrations.

Material:	<i>Parts per million</i>
Ammonia.....	100
Amylacetate.....	400
Arsenic.....	5
Benzol.....	75
Carbon Monoxide.....	100
Carbon Tetrachloride.....	100
Chlorine.....	1
Ether.....	400
Formaldehyde.....	20
Gasoline.....	1000
Hydrochloric Acid.....	10
Hydrogen Cyanide.....	20
Hydrogen Fluoride.....	3
Methyl Chloride.....	500
Methanol (Wood Alcohol).....	200
Phosgene.....	1
Sulphur Dioxide.....	10
Toluene.....	200
Turpentine.....	200
Xylene.....	200

	<i>Milligrams per cu. meter of air</i>
Cadmium.....	0.1
Lead.....	0.15
Mercury.....	0.1
Zinc Oxide Fumes.....	15.0
	<i>Particles under 10 microns in longest dimensions per cubic foot of air</i>
Silica	5,000,000
Any Dust.....	50,000,000

Product of particles per cubic foot of any dust, times the percentage of free silica, equals content of atmosphere.

F. After the installation of local exhaust systems or other controls, the resident engineer may require additional sampling and analysis to check the design and efficiency of the control equipment, devices or methods.

G. Air cleaning equipment should be located so as to permit the removal of dust or other collected material without creating a hazard and to allow for cleaning and repairing the apparatus without recontaminating the general atmosphere.

H. Operations or processes generating different kinds of dust, fumes, or vapors shall not be connected to the same exhaust system when the mixture results in the formation of toxic, flammable or explosive compounds.

I. Contaminated materials removed by exhaust systems shall be disposed of in such a manner that they do not re-enter the breathing zone of the worker or create a hazard to other employees or to the public.

J. Where persons may be exposed to harmful materials while fumigating, repairing or servicing equipment, or due to leaks or other similar conditions, approved type respirators shall be provided, properly maintained and used.

K. Air supplied to air line respirators shall be free from harmful dusts, fumes, vapors, or gases to the extent that inhalation of such air shall not constitute harmful exposure.

L. Whenever compressed air is used to supply respirators, an approved type regulator and filter shall be inserted in the supply line and the compressor shall be so located as to prevent contamination of the intake air. Air provided shall be of an equable temperature.

M. Where irritant or toxic substances come in contact with the skin or clothing, the employees shall be adequately protected by one or more of the following:

1. Necessary protective clothing, gloves, helmets, goggles and footwear.
2. An approved protective ointment for exposed skin areas.
3. Necessary facilities and approved solvents, soap and hot water for the removal of accumulated material and protective ointments.
4. Approved first-aid remedies for affected employees.
5. A fountain type water outlet for flushing the eyes.
6. Safety showers.

SECTION 02—POISON IVY—OAK—SUMAC 8314.02

A. In areas where employees are exposed to poison ivy, oak or sumac, the following precautions shall be observed:

1. All employees shall be instructed in identification of the plants.
2. Where practicable the plants shall be removed or destroyed.
3. Burning of plants shall be in isolated areas.
4. Highly sensitive persons shall not be exposed.
5. Necessary protective clothing, gloves, etc., shall be worn.
6. Protective ointment shall be provided, sodium perborate dry, equal to West Disinfectant Co. Formula 99.
7. Alcohol or laundry soap and hot water will be available for washing exposed parts.
8. Approved first-aid remedies shall be provided for treatment of affected skin areas.
9. Immunization treatments given under the direction of a physician are recommended.

SECTION 03—INSECTS—VERMIN—SNAKES 8314.03

A. Protection against hazards involving insects, vermin, or snakes shall include one or more of the following controls:

1. Boots, hoods, netting, gloves or other necessary personal protection.
2. Repellants.
3. Drainage or spraying of breeding areas.
4. Burning or destruction of nests.
5. Smudge pots for protecting small areas.

6. Elimination of unsanitary conditions which propagate insects or vermin.
 7. Extermination measures against rodents.
 8. Fumigation.
 9. Approved first-aid remedies for affected employees.
- B. Employees shall be instructed in proper protective measures.

SECTION 04—HOT SUBSTANCES

8314.04

- A. All heating or melting kettles shall be placed on a level, firm foundation and protected against traffic, tipping or similar hazards.
- B. Heating or melting kettles shall not be permitted inside of buildings of combustible construction or adjacent to inflammable or combustible material.
- C. Plumbers' or tinnerns' furnaces, blow torches and alcohol torches are permitted in buildings except those where the use of open flame devices is prohibited.
- D. An approved type of fire extinguisher shall be available at all locations where heating or melting kettles are used or hot substances are applied.
- E. Burners on kettles shall be shut down while refueling.
- F. Fires under heating or melting kettles shall not be left unattended.
- G. All asphalt or tar heating kettles shall be provided with a close fitting lid.
- H. A temperature recording device shall be provided for all asphalt or tar melting kettles.
- I. Asphalt or other substances to be heated in open kettles shall not be thinned nor diluted by the addition of any flammable solvent.
- J. All ladles and material shall be dry before being placed in heated material.
- K. At each location where asphalt or tar buckets are used, a piece of wet burlap or soft canvas shall be available to extinguish a fire in the contents.
- L. Proper runways or passageways, clear of obstructions shall be provided for all persons carrying hot substances.
- M. All hoisting gear used in handling hot substances shall be adequate for the loads imposed and shall be securely and substantially braced.

N. Hot substances shall not be hoisted nor handled in such a manner as to endanger workmen.

O. All inclosed areas in which hot substances are being heated or applied shall be properly ventilated. If natural ventilation is insufficient, mechanical ventilation shall be provided.

P. Exhaust pipes on trucks spraying hot asphalt or other volatile materials shall be equipped with flame arrestor and so located that hot gases cannot ignite vapors from the spray nozzles.

Q. Operation of spray nozzles on trucks shall be by remote control so located that spray does not come in contact with the operator.

R. Proper protective equipment and clothing shall be provided for all persons handling hot substances.

ELECTRIC AND GAS WELDING AND CUTTING

SECTION 01—GENERAL

8315.01

A. Electric arc welding apparatus shall comply with the National Electrical Manufacturers Association Electric Arc Welding Machine Standards No. 48-81, December 1942, and shall be installed in accordance with requirements of the National Electrical Code.

B. Gas welding and cutting equipment shall be listed by Underwriters' Laboratories, Inc., Chicago, Illinois, or by Factory Mutuals Laboratories, Boston, Massachusetts.

C. All persons engaged in the installation, maintenance and operation of apparatus and equipment shall be qualified by experience or instruction in safe methods before being permitted to engaged in such operations.

D. All apparatus and equipment shall be competently inspected before being placed in service, and weekly thereafter. Defective apparatus and equipment shall be removed from service, replaced, or repaired and re-inspected before again being placed in service.

SECTION 02—GAS WELDING AND CUTTING

8315.02

A. Acetylene generators, fuel gas and oxygen piping systems, coupler blocks and manifolds shall be installed, maintained and operated in accordance with the requirements of American

Standards Association Standard for Safety in Electric and Gas Welding and Cutting Operations. Z49.1--1944.

B. All portable cylinders used for the storage and shipment of compressed fuel, gas or oxygen, shall be constructed, maintained and marked in accordance with the regulations of the Interstate Commerce Commission.

C. Cylinders stored in the open shall be protected against accumulation of ice and snow and from the continuous direct rays of the sun when high temperatures prevail. Warm (not hot) water shall be used to thaw ice in cylinder valve outlets.

D. Cylinders shall be stored in definitely assigned places away from elevators, stairs, gangways, or entrances to confined spaces. Assigned storage spaces shall be located where cylinders will not be knocked over or damaged by passing or falling objects.

E. Cylinders containing oxygen shall be stored well away from cylinders containing combustible gases.

F. Cylinders permitted inside the building shall be stored in a well protected, ventilated, dry location, well away from highly combustible material such as oil or excelsior and away from stoves, radiators, or other sources of heat.

G. Valve-protection caps shall always be in place, hand-tight except when cylinders are in use or connected for use.

H. Oxygen shall not be used as a substitute for compressed air in pneumatic tools, in oil preheating burners, to start internal-combustion engines, to blow out pipe lines, to "dust" clothing or work, or to create pressure, or for ventilation.

I. Fuel gas cylinder valves shall be opened only with tools specifically designed for that purpose. Oxygen cylinders, the valves of which cannot be opened by hand, shall be set aside and the supplier notified.

J. Tampering with safety devices in cylinders or valves is prohibited.

K. Cylinders shall not be dropped or handled roughly.

L. A suitable platform shall be used when handling cylinders with a crane or derrick. Slings or electric magnets shall not be used.

M. A suitable truck, chain, or steadying device shall be used to keep cylinders from being knocked over while in use.

N. Fuel gas or oxygen cylinders will not be used without first attaching a regulator to the cylinder valve.

O. Cylinder valves not provided with fixed hand wheels shall

have keys or handles on valve spindles or stems while cylinders are in service.

P. Operators shall be required to follow the procedure outlined by the manufacturer of the apparatus in use, insofar as they deal with the sequence of operations in lighting, adjusting, and extinguishing blowpipe flames and connecting the apparatus to sources of gas supply. An acetylene cylinder valve shall not be opened more than $1\frac{1}{2}$ turns of the spindle.

Q. Cylinders shall be kept at sufficient distance from the actual welding or cutting operations so that sparks, hot slag, or flame will not reach them.

R. Cylinder valves shall be closed when work is finished, or before moving cylinder. Valves of empty cylinders shall be closed.

S. Empty cylinders shall be marked "MT" and segregated from full cylinders.

T. No one shall attempt to mix gases in a cylinder, refill a cylinder, or use it for purposes other than intended by supplier.

U. Fuel gas cylinders found to have leaky valves or fittings which the closing of the valve will not stop shall be taken into the open away from any source of ignition and slowly drained of gas. Cylinder will be tagged and the owner notified.

V. Keep oxygen cylinders and fittings away from oil or grease. Cylinders, cylinder valves, couplings, regulators, hose, and apparatus shall be kept free from oily or greasy substances and shall not be handled with oily hands or gloves. Oxygen cylinders should never be handled on the same platform with oil or placed in a position where oil or grease is likely to fall upon them. A jet of oxygen should never be directed at oily surfaces, greasy clothes, or into a fuel oil or other storage tank.

W. Concrete floors shall be protected from the heat of the blowpipe flame or hot slag to prevent spalling.

X. Flames shall not be used to detect leaks.

Y. All hose used shall comply with Federal Specifications ZZ-H-461A HOSE: GAS, ACETYLENE, AIR, HYDROGEN AND OXYGEN.

When parallel lengths of oxygen and acetylene hose are taped together, not more than four (4) inches out of each eight (8) shall be covered with tape. Hose shall not be crimped or kinked.

Z. Hose connections shall be made through substantial fit-

tings, and clamped or otherwise securely fastened so as to withstand, without leakage a pressure twice as great as the maximum pressure on the system.

SECTION 03—ARC WELDING AND CUTTING 8315.03

A. Before starting operations, the operator shall make certain that all electrical connections are securely made. The work connection should be attached firmly to the work. Work leads shall be as short as possible.

B. All equipment shall regularly be checked to make certain that electrical connections and insulation on the holders and cable are in good order. Unsafe equipment shall be reported to the proper supervisors, and use of such equipment discontinued until safe to operate.

C. Proper switching equipment for shutting down the welding machine shall be provided on or near the welding machine. A suitable motor starter of the hand or magnetic type shall be used.

D. A suitable means of control for varying the welding current over the specified welding range shall be provided. A suitable current-indicating device which shows the welding current corresponding to the setting of the generator control shall also be provided.

E. All parts of the motor and generator equipment shall be suitably inclosed and protected.

F. Neither terminal of the welding generator shall be bonded to the frame of the welder.

G. All electrode holders shall be fully insulated, specifically designed for arc welding and of a capacity to safely handle the maximum rated current required by the electrodes with which the holder is intended to be used.

H. Electrodes shall be removed from the holder when not in use.

I. All welding cables shall be of the completely insulated, flexible type, of proper size, etc., for the maximum current requirements of the work.

J. Only rubber-covered cable free from splices shall be permitted for a minimum distance of 10 feet from the electrode holder.

K. Lengths of cable shall be connected by substantial connectors of a capacity at least that of the cable.

L. Cable lugs shall be soldered to the cable and securely

fastened to give full electrical contact. The exposed metal parts of the lugs shall be completely covered with rubber tape and protected with friction tape or equivalent protective covering.

M. All ground connections shall be mechanically strong and electrically adequate for the required current.

N. Proper electrical contact shall exist at all joints when a building structure or pipe line is used temporarily as a ground-return circuit.

O. Where a structure or pipe line is continuously employed as a ground-return circuit, all joints shall be bonded and no condition of electrolysis or fire hazard permitted to exist.

P. Pipe lines containing gases or flammable liquids, or conduits carrying electrical conductors will not be used for a ground-return circuit.

Q. Welding cables shall be kept dry where practicable, and free from grease and oil.

R. A cable which has become worn, exposing bare conductors, shall have that portion properly insulated.

S. When the operator has occasion to leave his work or stop work for any appreciable time, the power-supply switch in the equipment should be opened and the unit disconnected from the source of power.

T. Cables shall be substantially supported overhead, if practicable. If this cannot be done, and cables are laid on floor or ground, they should be protected in such a manner that they will not be damaged or interfere with safe passage of employees. Special care shall be taken to see that welding supply cables are not in proximity to power-supply cables or other high-tension wires.

SECTION 04—FIRE PREVENTION

8315.04

A. Welding and cutting operations shall be conducted only in locations that have been freed from fire hazards.

B. Before welding or cutting on bulkheads, decks or similar surfaces, an inspection shall be made to see that no combustible material is present on either the front or back side of the surface.

C. Welding operations in rooms or compartments containing flammable vapors or in closed tanks or other containers that have held flammable gases or liquids shall be in compliance with the provisions of Section 8313.01, Flammables. When welding or cutting is being done in the vicinity of combustible material,

special precautions shall be taken to prevent fire. Wooden floors should preferably be covered with metal or other suitable non-combustible material.

D. Approved fire-extinguishing equipment shall be maintained near welding and cutting operations. In confined spaces, the use of extinguishing agents that are hazardous to the health of workers shall not be used. When combustible material has been exposed to either sparks or heat, a watcher shall be assigned to remain at the location for at least 30 minutes after the job is completed.

E. Installed fire protection shall be maintained while welding or cutting operations are in progress.

SECTION 05—PROTECTIVE CLOTHING AND EQUIPMENT

8315.05

A. Flameproofed gauntlet gloves shall be worn by all operators.

B. One or more of the following items of protective equipment shall be provided as the work hazards require:

Flameproofed aprons or clothing

Fire resistant leggings, boots or spats

Sheet metal screens to protect legs of workmen

Capes or shoulder covers and skull cap of leather or other suitable material when engaged in overhead welding

Ear protectors

C. Helmets or hand shields shall be used in all arc welding operations. Goggles shall be worn on all welding, cutting or burning operations.

D. Filter lenses in helmets, shields and goggles shall be in accordance with requirements of the American Standards Association Standard for Safety in Electric and Gas Welding and Cutting Operations, Z49.1-1944.

E. Where continuous welding with the electric arc is carried on in a building, the walls of the welding bay shall be painted flat black or other non-reflecting color.

F. Where practicable the welders shall be inclosed in individual booths or by portable flameproofed screens painted flat black or other non-reflecting color. Booths and screens shall permit circulation of air at floor level.

G. Where it is impracticable to inclose or isolate arc welding operations, all persons other than welders working within seventy-five (75) feet of the arc shall wear approved goggles.

SECTION 06—VENTILATION

8315.06

A. In welding or cutting lead or cadmium coated metals or metals covered with lead mercury or cadmium bearing paint, or lead bearing steels, an air line respirator, hose mask or local exhaust ventilation shall be used. For intermittent operations, a filter type respirator approved by U. S. Bureau of Mines for lead fumes may be used.

B. In welding shop or in inclosed areas where welding is frequently carried on, ventilation shall be in accordance with the requirements of the American Standards Association Standard for Safety in Electric and Gas Welding and Cutting Operations, Z49.1-1944.

C. All welding and cutting operations carried on inside small inclosed or restricted spaces such as tanks, boilers, pressure vessels and compartments or holds of ships shall be ventilated to prevent the accumulation of toxic gases or oxygen deficiency. All air replacing that withdrawn shall be clean and respirable. Where it is impracticable to provide such ventilation, air line respirators or hose masks shall be used.

D. When welding operations are carried on inside galvanized metal, brass or bronze containers, or where fluorine fluxing materials are used, an approved type air line respirator or hose mask shall be used.

E. In lead burning operations, an air line respirator or hose mask or filter type respirator approved by U. S. Bureau of Mines shall be used. In closed containers, only air line respirators or hose masks shall be used.

F. In metal spraying operations with non-lead alloys, a positive ventilating device or approved type air line respirator or hose mask shall be used. When lead or its alloys are used only air line respirators or hose masks shall be used.

SECTION 07—CONFINED SPACES

8315.07

A. When welding, cutting or burning is performed in confined spaces, the cylinders and other heavy welding or cutting equipment shall be left on the outside.

B. In confined spaces where the means of exit is a manhole or other small opening, means shall be provided for quickly removing workers in an emergency. An attendant shall be stationed outside the exit at all times while work is in progress.

C. When arc welding in a confined space is suspended for any substantial period of time such as during lunch or overnight, all

electrodes shall be removed from the holders and such equipment removed or disconnected from the source of power.

D. When gas welding, cutting or burning in confined spaces is suspended, torch valves shall be closed and gas and oxygen supply to torch positively shut off outside the confined space.

MACHINERY AND MECHANIZED EQUIPMENT

SECTION 01—GENERAL

8316.01

A. Inspection.

1. Machinery and mechanized equipment, hereinafter called equipment, shall not be placed in operation until it has been inspected by a qualified person and found to be in safe operating condition.

2. A regular weekly inspection shall be made of all equipment.

3. Defective equipment shall be removed from service, repaired and reinspected before being again placed in service.

4. Current records of all inspections shall be kept on file and be available for review by representatives of the Safety Section.

5. All self-propelled equipment or combinations of equipment shall at night and at other times when visibility is less than five hundred (500) feet be equipped with at least one white light on the front and one red light in the rear.

6. Riding on equipment by unauthorized persons is prohibited.

7. Getting on or off any equipment while it is in motion is prohibited.

B. Guarding, Safety Devices, Ladders, Platforms, Etc.

1. All belts, gears, shafts, clutches, drums, flywheels, chains, and other reciprocating or rotating parts of equipment shall be guarded.

2. Platforms, footwalks, steps, ladders, handholds, guardrails, and toeboards shall be provided on all equipment where necessary.

3. Means shall be provided to prevent the starting of equipment by unauthorized persons.

4. A suitable operating floor or platform of nonslip material shall be provided for all equipment operators.

5. No guard, safety appliance or device shall be removed or made ineffective except for the purpose of immediately making repairs or adjustments and then only after the power has been shut off. Such guards and devices shall be replaced immediately after completion of repairs and adjustments.

6. Operators of equipment shall have suitable protection against the elements, falling objects, swinging loads, and similar hazards.

7. All windows in shields, cabs, or inclosures on equipment shall be of safety glass.

8. A warning device shall be provided on all equipment where there is danger to workmen in moving the equipment or from swinging loads, buckets, booms, etc.

9. All current carrying parts of electrically operated equipment shall be properly isolated or guarded. All noncurrent carrying metal parts shall be properly grounded.

10. All equipment and exhaust, steam or other lines carrying high temperatures located where they endanger employees or create a fire hazard shall be covered with suitable insulating material.

11. Exhausts from all equipment powered by steam or internal combustion engines shall be piped to the outside and so located that they do not endanger workmen or obstruct the view of the operator.

C. FLAMMABLES.

1. Refueling any type of equipment with liquid fuel while the motor is running is prohibited.

2. Smoking or the use of open flames on or in the immediate vicinity of equipment being refueled is prohibited.

3. No solvent with a flash point below 100° F. shall be used for the cleaning of equipment or parts.

4. All gasoline or other highly flammable fluids used on equipment shall be handled by pumps or in approved type safety cans. Gasoline, lubricating oil, and other flammable fluids shall not be stored on equipment except in fuel tanks or approved type safety cans with a capacity of not more than 1 day's requirements.

5. Fuel tank filler openings shall not be located in such a position that spills or overflows can run down on a hot motor, exhaust pipe, or battery.

6. An approved type fire extinguisher shall be located on or in close proximity to all equipment.

D. Repairs.

1. All equipment shall be shut down for repairs and shall have an "Out of Order" sign posted; such sign shall not be removed until repairs are completed, equipment inspected and approved for service.

2. When repairs are necessary on mobile equipment, it shall be removed to a location which will not interfere with other operations and provide a safe workplace for repairmen.

3. Equipment which is suspended in slings or supported by hoist or jacks for repairs shall be blocked or cribbed before men are permitted to work underneath.

4. When repairs are made remote from the source of power on conveyors, cableways, etc., chains, blocking, or other such devices shall be used to prevent injury in case of accidental starting.

5. Before starting repairs on electrically powered equipment, the switch shall be locked in open position. The key to switch lock shall be retained by the repairman.

E. Miscellaneous.

1. Accumulations of debris, oil, grease, oily rags, waste, etc., on equipment shall not be permitted.

2. Safe load capacity and/or operating speeds shall be posted on all equipment and shall not be exceeded.

3. Equipment shall be placed on a firm foundation and properly secured in place.

4. Before moving mobile equipment, a survey of the area in which it is located shall be made to check for overhead wires.

5. Portable equipment shall not be moved into, out of, or operated in any area containing high voltage electric lines, pipelines, excavations and similar hazards until the approval of a responsible supervisor has been obtained.

6. Equipment shall not be operated within 10 feet of high voltage lines unless the current has been shut off.

7. Equipment shall not be located or operated so that slides, blasts, or the collapse of trenches or excavations can endanger employees, or damage equipment.

SECTION 02—CRANES, HOISTS, AND DERRICKS 8316.02**A. Miscellaneous.**

1. All cranes, hoists, and derricks shall have a minimum factor of safety of five.

2. All cranes, hoists, and derricks shall be equipped with proper dogs or pawls and braking equipment, which shall be capable of effectively braking and holding a weight of at least one and one-half times the full rated load.

3. Extensions or outriggers will not be permitted unless designed by the manufacturer of the equipment on which they are to be used.

4. Capacity plates shall be attached to all cranes, hoists, and derricks. On boom cranes and derricks, they shall clearly indicate the safe load in tons for maximum and minimum positions of the boom and for at least two intermediate stations. These indications shall be for loads both with and without outriggers.

5. There shall be at least two full wraps of cable on the drums of cranes, hoists, and derricks at all times of operation.

6. Riding on loads, hooks, hammers, material hoists, or buckets shall not be permitted.

7. Loads, booms, buckets, etc., shall not be swung over the heads of workmen.

8. While hoisting equipment is in operation, the operator shall not be permitted to perform any other work.

9. While a load is suspended from a crane or derrick, or on a hoist or elevator platform, the operator shall not leave his position at the controls until the load has been landed or the bucket or platform returned to the ground level.

10. Side pulls shall not be made with cranes or derricks. The crane boom shall be directly over the load to be lifted.

11. All slings, cables, chains, and other gear used in connection with cranes, hoists and derricks, shall be under supervision of and maintained by properly qualified persons.

12. A notice shall be posted in the cab of every derrick, crane, dragline, etc., prohibiting the operator from bringing the boom or other part of machine within 10 feet of high voltage wires.

B. Material—Hoists and Towers.

1. The shaftways and cars of hoists shall be constructed of sound material capable of sustaining the maximum rated load with a factor of safety of five. The tower shall be crossbraced

and strutted and well guyed or otherwise strongly anchored. Towers shall be vertically straight and plumb.

2. Landing platforms connecting the hoist shaftway to the building shall be provided with guardrails and toeboards.

3. Towers shall be provided with suitable platforms, with guardrails and toeboards at each level where men work.

4. The shaftways of hoists shall have a solid or substantial grille or lattice work enclosure on all sides not used for loading or unloading, extending to a height of at least 7 feet from each landing. The entrance to the shaftway shall be protected by a hinged bar placed at least 18 inches from the flush line of the shaftway. Where the entrance to shaftways is exposed to hazard from falling objects, a substantial covering shall be provided.

5. The cars of all hoists shall be provided at the top with a cover of either solid material or grille work. The covers shall be set back not more than 6 inches from the landing threshold and shall be hinged on the landing side not less than 18 inches back.

6. Builders' hoists shall not be operated when men are working in or on a hatchway or tower.

7. No person shall be permitted to enter a hoist pit until the car or bucket has been landed on suitable blocking or horizontal timbers placed across shaft opening.

C. Signal Systems.

1. A standard signal system shall be used on all cranes, hoists and derricks.

2. Hoist signals shall be given only by the designated signalman.

3. Where the signalman cannot be observed by the operator, a mechanical or electric signal system shall be used.

4. The signal code shall be posted adjacent to the signal device and at each work level and at operator's location and shall be clearly visible.

D. Pile Driving.

1. The hose on all steam or air hammers shall be lashed or otherwise fastened to prevent injury to workmen in case of a broken connection.

2. While inserting a pile or when not in use, the hammer shall be blocked in the leads.

SECTION 03—WOODWORKING MACHINERY**8316.03****A. Miscellaneous.**

1. Woodworking machinery shall be operated only by properly qualified persons.

2. Woodworking machinery shall not be permitted to run unattended.

3. Suitable means shall be provided for the removal of sawdust, chips and shavings on all woodworking machinery.

4. Band saws shall not be operated at temperatures below 45°.

5. Cylindrical cutterheads shall be used on all jointers and planers.

6. A pusher stick or block shall be used in all close operations on circular saws, jointers, and sanders.

7. Cracked saws shall be taken out of service immediately. Drilling to prevent further cracking is prohibited.

8. All woodworking tools shall be kept sharp and maintained in safe working condition.

9. Sharpening, brazing, welding, and repairing of woodworking tools and equipment shall be done only by properly qualified persons.

B. Guarding.

1. All belts, pulleys, clutches, gears, sprockets, spindles, and other rotating and reciprocating parts shall be properly guarded.

2. The peripheral length of circular saws beneath saw tables shall be guarded.

3. Positive locking belt shifter or suitable stop and start buttons shall be provided on all woodworking equipment. These devices shall be located within easy reach of the operator.

4. Chip screens or safety goggles shall be provided at all locations where there is danger of injuries from sawdust, chips, or other flying particles.

5. Band saws shall be fully inclosed by a band guard except at the point of operation.

6. All swing cut-off and radial saws shall be equipped with a limit stop which will prevent the outside edge of the saw from extending beyond the edge of the table.

7. That section of cutterhead in back of the guide shall be guarded on all jointers.

C. Point of Operation.

1. The point of operation on circular saws, band saws, jointers, borers, shapers, sanders, and other woodworking machinery shall be properly guarded.

2. All circular rip saws shall be provided with a hood guard, splitter, and kick-back device.

3. On all band saws a telescopic guard attached to the gauge block and extending to the upper wheel inclosure shall be used.

4. Where the volume of typical work is large, the use of a jig or fixture may be permitted with the approval of the superintendent.

FLOATING PLANT**SECTION 01—INSPECTION AND CERTIFICATION 8317.01**

A. Floating plant requiring an inspection and/or certificate under the regulations of the United States Coast Guard shall have such certificate posted before starting work.

B. All floating plant shall be reinspected and the certificate of approval renewed annually. For major repairs or alterations, floating plant shall be taken out of service, reinspected, and the certificate returned or reissued before being placed in operation.

C. All persons requiring a license under the Regulations of the United States Coast Guard shall have in their possession a current license before being permitted to operate floating plant or equipment.

D. Weekly inspections shall be made in connection with accident prevention, sanitation and health, on all floating plant and a record kept of such inspections.

SECTION 02—GANGWAYS, GUARDRAILS, PLATFORMS, ETC. 8317.02

A. Gangways equipped with guardrails or life lines shall be provided for boarding or leaving all floating plant. Where the use of gangways is impracticable, ladders shall be provided. All gangways and ladders shall be properly secured to prevent slipping or falling.

B. All gangways, ladders, stairways, passageways, etc., shall be kept free of ice, snow, grease, mud, and other material. Sand, cinders, calcium chloride or other similar material shall be used where slippery surfaces cannot be avoided.

C. Nonslip surfaces shall be provided on all stair treads, ladders, floor plates, platforms, catwalks, and walkways, and on the weather side of all doorways opening on deck.

D. On stairways, companionways, and passageways where overhead clearance is limited suitable warning signs shall be posted.

E. Guardrails, life lines, or gratings shall be provided at all deck openings.

F. Handrails shall be installed on all stairways, ship ladders, companionways, and other such places where danger of falling exists.

G. Bulwarks, guardrails, or life lines shall be provided on all floating plant on which men are regularly employed or quartered. Similar provisions shall be made on all floating plant where practical.

H. All cargo and material runways or stages shall be provided with a substantial curb on each side at least six (6) inches high.

I. Pipe lines shall be equipped with walkways which shall have a minimum width of 20 inches. Walkways shall be securely anchored to the pipe line supports. A guardrail equivalent in strength to a wood rail (2 by 4 inches) shall be provided on at least one side of walkway and shall be secured to uprights at intervals of not more than eight (8) feet. Such guardrail shall be not less than thirty-six (36) nor more than forty-two (42) inches in height.

J. Catwalks or platforms with guardrails shall be provided at all locations where men are regularly employed above decks, floor plates, or over water.

K. All persons working aloft except on catwalks or platforms provided with guardrails shall be equipped with safety belts and life lines.

L. On all floating plant a walkway not less than two (2) feet wide shall be maintained outboard of all cargo or other materials stored on deck.

M. A three-fourth- ($\frac{3}{4}$ -) inch line with knots twelve (12) inches apart shall be hung over the side of floating plant at intervals of not more than fifty (50) feet.

SECTION 03—MACHINERY AND DECKGEAR

8317.03

A. No person shall be permitted to enter a boiler, tank, cofferdam, double bottom, or other confined area until proper check

has been made to insure a safe air supply, necessary protective equipment has been provided, and an attendant stationed at the entrance.

B. All belts, gears, chains, pulleys, couplings, projecting set screws, keys, and other rotating or reciprocating parts when exposed to hazardous contact shall be enclosed or properly guarded.

C. All equipment and exhaust, steam, or other lines carrying high temperatures, where they endanger employees or create a fire hazard shall be guarded or covered by adequate insulation.

D. Engine throttle valves, boiler stops, starting switches and devices shall be locked in off position before starting repairs and key to such lock shall be retained by person making repairs.

E. Drip pans shall be installed at all locations where waste from engines or machinery may accumulate. Pans shall be emptied regularly.

F. Remote control shall be provided on floating plant for fuel shut-off valves, boiler stops, engine throttles, safety valves, and fixed fire extinguishing systems. Such controls shall be located on deck in such a position that they are protected against accidental operation but may be readily accessible to operate in an emergency.

G. Hooks, shackles, rings, pad eyes, chains, slings, etc., that have been bent, twisted, or otherwise damaged shall be removed from service.

H. All lines, gear, cargo, and other material shall be securely stowed or arranged in an orderly manner out of walkways, passageways, and work areas.

I. When handling lines on a power capstan or winch head, two men shall be used; one to handle lines and the other to operate such capstan or winch head.

J. The use of cranks on hand-powered winches or hoists is prohibited. Wheels without projecting spokes or pins shall be used.

K. Employees shall be required to stand clear of all chains, lines, and cables under strain.

L. All permanent running rigging when exposed to hazardous contact shall be properly guarded.

M. Before anyone is permitted to work on cutterheads, suction ladders, stern wheels or at such locations, chains, wire lashings, safety dogs or other similar devices shall be used to prevent accidental starting.

N. Axes in suitable brackets shall be provided forward and aft on all towing vessels.

O. All loose ends of wire rope shall be serviced or lashed to prevent hazardous contact.

SECTION 04—MISCELLANEOUS

8317.04

A. Suitable launches or tenders shall be provided for transportation to or from floating plant.

B. Employees shall not be permitted to sit or stand on deck railings, shafting, winch heads or other such hazardous places.

C. During inclement weather, at night, or in highly hazardous locations, no person, except watchman, shall be permitted to work alone.

D. Adequate lighting shall be provided at all times on all floating plant, pipelines, piers, landings and other adjacent areas used by the crew or other authorized persons.

E. All deck fittings and similar stumbling hazards shall be painted yellow.

F. A suitable whistle, siren, horn, or other such device shall be provided on all floating plant which is unattended by another vessel so equipped for signaling to shore or other vessels.

G. On all floating plant where ten (10) or more men are quartered, one man shall be on watch at all times to guard against fire, collision and other such hazards.

H. When engaged in operations where floating plant may be endangered by hurricanes, storms, or floods, plans shall be made in advance for removal of plant and evacuation of personnel in emergencies. Such plans shall be approved by the District Engineer.

I. Grappling irons or drags shall be provided at all locations where men are employed on floating plant or adjacent to water.

SECTION 05—LAUNCHES AND MOTORBOATS

8317.05

A. Launches and motorboats shall be operated by regularly designated operators or crews.

B. A daily inspection shall be made of all fuel lines, electric wiring, bilges, bilge pumps, exhaust lines, ventilating equipment, fire-extinguishing equipment, and lifesaving equipment on launches and motorboats.

C. All launches and motorboats having power plants located in cabins or compartments shall be equipped with a built-in CO₂ or other equally effective type of fire-extinguishing system.

At least one carbon tetrachloride CO₂ or dry powder pressure type hand fire extinguisher shall be carried on all launches and motorboats including outboards.

D. All launches and motorboats having gasoline power plants located in cabins or compartments shall be equipped with an exhaust fan for ventilating engine spaces and bilges. Such fan shall be of the explosion-proof types and arranged so that the engine cannot be started until the engine space and bilges have been properly ventilated. For diesel power plants, natural draft ventilation with permanently open inlet and outlet ducts extending to the bilges shall be provided. Inlet and exhaust ducts shall be equipped with suitable cowls or exhaust heads.

E. All electrical wiring shall be oilproof, wear-resisting cable. All switches in motor compartment shall be non-sparking type. Spark plugs shall be protected by insulating nipples or hoods.

F. No running motors, smoking, fires, open flames, or other sources of ignition shall be permitted while launches or motorboats are being refueled.

G. Gauge glasses shall not be installed on fuel tanks. Other means for gauging fuel shall be provided.

H. A cut-off valve shall be provided in the fuel line at the tank in all gasoline powered launches or motorboats to which shall be attached three separate pulls located remote from each other.

I. The fuel valve shall be closed at the tank on all launches and motorboats when shutting down for the night or more than eight hours.

J. All carburetors on launches or motorboats shall be equipped with a backfire trap or flame arrestor. A screened drip pan which is emptied continuously by suction from the intake manifold shall also be provided.

K. The maximum number of passengers permitted on all launches or motorboats shall be posted and shall not be exceeded.

L. No person except man tending lines shall be permitted to board or leave a launch or motorboat until such launch or motorboat has been securely tied up.

M. Life preservers shall be provided for all passengers and crew members of launches and motorboats.

N. The presence of fumes, vapors, or gases shall require a test to be made for flammable or toxic concentrations and men shall not be permitted to work in or occupy such quarters until safe to do so.

SECTION 06—DRILLS

8317.06

A. On all floating plant having regular crews and on which men are employed or quartered, the following drills are required to be held at least once monthly.

1. Boat or abandon ship drills.
2. Fire drills.
3. Man overboard or rescue drills. This applies to all locations where rescue skiffs are required under these regulations.

B. When drills are held in accordance with these requirements, each drill shall be held separately at least one hour apart.

C. A suitable electrical or mechanical alarm device shall be provided on all floating plant covered in these requirements.

D. A record of all drills shall be kept and be available for inspection.

E. All equipment and devices used in connection with such drills shall be inspected during drills and necessary repairs or replacements made. Such repairs and replacements shall be noted in record of drill.

SECTION 07—RING BUOYS

8317.07

A. Ring buoys shall be provided and located where readily available under the following conditions:

1. On vessels, launches, barges and other floating plant up to one hundred (100) feet in length, two (2) shall be provided. Two (2) additional shall be supplied for each increase in length of one hundred (100) feet or fraction thereof.
2. On pipe lines, walkways, wharfs, piers, bulkheads, lock walls, etc., and on scaffolds or platform extending over water, at intervals of not more than two hundred (200) feet.

B. At least one ring buoy as required under A-1 and every third one thereafter shall have an approved water light attached. For night operations every other ring buoy as required under A-2 shall have an approved water light attached.

C. On gasoline and oil barges or other locations where open flames may cause a fire or explosion, electric water lights shall be used.

D. At least one ring buoy on each side as required under A-1 and all ring buoys as required under A-2 shall have a life line attached and coiled so that it will not foul on release. Such line shall consist of not less than fifty (50) feet of three-eighths ($\frac{3}{8}$) inch line.

SECTION 08—SKIFFS

8317.08

A. The permissible number of passengers in skiffs shall be the number that can safely be placed in fixed seats allowing not less than eighteen (18) inches of seat per passenger. Each skiff shall have the number of persons allowed to be carried plainly marked on each bow in letters and figures not less than three-fourths ($\frac{3}{4}$) of an inch high.

B. No person shall be permitted to use a skiff or small boat unless he is properly qualified and instructed in the safe handling of same.

C. Skiffs or small boats will not be used by employees without specific permission from the supervisor in charge.

D. One or more lifesaving skiffs shall be provided for each floating plant and for each shore establishment where men are working adjacent to water. Each skiff shall be kept afloat or ready for instant launching. Such skiffs shall be used only for lifesaving and lifesaving drills.

E. Each lifesaving skiff shall be equipped with not less than four (4) oars, with oarlocks securely attached to the gunwales, one (1) boat hook (sharp pointed hook), and one (1) ring buoy with fifty (50) feet of three-eighths ($\frac{3}{8}$) inch line attached.

F. One-half ($\frac{1}{2}$) inch line shall extend along outer side of gunwales and stern and shall be securely fastened at intervals of not more than three (3) feet. Such lines shall hang loosely and have a seine float placed in each bight.

SECTION 09—LIFE VESTS (WORK VESTS)

8317.09

A. Life vests shall be a type approved by the Office of the Chief of Engineers.

B. Life vests shall support a dead weight of sixteen (16) pounds for at least three hours in fresh water. All life vests in service shall be inspected once a month and tested by immersion at intervals of not over six months. Any vest which does not pass the test shall be removed from service.

C. All covers, pads, ties, fastenings, etc., shall be maintained in good condition.

D. A sufficient number of life vests shall be provided for all persons coming under these regulations.

E. Life vests shall be worn by all persons:

1. On pipeline, pontoons, rafts, and float stages, etc.
2. On floating plant not equipped with bulwarks, guardrails or life lines.
3. On buildings or structures extending over water except where proper scaffolds or platforms with guardrails, or safety belts and life lines are provided.
4. When working over the side of a vessel or floating plant.
5. Working alone or at night in hazardous locations.
6. In skiffs, small boats or launches except when in an enclosed cabin or cockpit.

SECTION 10—FIRE PREVENTION AND PROTECTION

8317.10

A. All combustible debris on floating plant shall be continually removed.

B. On all floating plant fifty (50) feet or over in length constructed of or having on board combustible material, not less than four (4) fire buckets with lanyards attached shall be provided. On floating plant less than fifty (50) feet in length and on all launches, motorboats, work boats, etc., at least one fire bucket shall be provided. One two-and-one-half (2½) gallon soda and acid or pump tank extinguisher may be substituted for each fire bucket.

C. Floating plant over fifty (50) feet in length on which ten (10) or more men are regularly employed or quartered shall be provided with a fire pump and sufficient outlets and one and one-half (1½) inch hose to reach any point on board.

D. All gasoline storage areas, paint lockers, lamp lockers, motor compartments, fire and engine rooms, shall be equipped with a "built-in" CO₂, foam, fognozzle or steam fire extinguishing system. These locations shall also be equipped with one or more approved type hand fire extinguisher.

E. Gasoline and other flammable fluids shall not be stored below decks on floating plant except in tanks especially provided for the purpose. Such tanks shall be equipped with fill pipes and vents carried outside the hull or structure at a safe location. All vents shall be equipped with flame arrestors.

F. Gasoline or other flammable fluids in drums, and flammable or toxic gases shall be stored on deck in a safe location. All

containers shall be properly secured, protected against injury and so arranged that they can be thrown overboard on emergency.

G. Handling of all flammable fluids shall be in approved type safety cans.

H. Oily rags, waste, etc., shall be kept in covered metal containers.

SECTION 11—SANITATION—LIVING QUARTERS 8317.11

A. All water used for drinking, cooking, dishwashing, and bathing shall be from a source known to be free of pollution. If such water is not available, a water treatment unit or still shall be provided.

B. On all vessels using other than potable water at outlets in galley, toilets, or other locations where it may be mistaken for drinking purposes shall have all such outlets marked "UN-FIT TO DRINK."

C. Hot and cold running water shall be supplied to all galleys, toilet rooms, showers, and laundry trays.

D. Water closets shall be provided in the ratio of one for each fifteen (15) persons or fraction thereof.

E. Urinals may be substituted for one-third ($\frac{1}{3}$) of the required number of water closets.

F. Open-front seats shall be provided in all water closets.

G. All toilet seats shall be so constructed or finished as to be impervious to moisture.

H. All water closets and urinals shall be provided with a sufficient supply of water for flushing purposes and automatic or manual flushing arrangements.

I. Wash bowls shall be provided in the ratio of one for each fifteen (15) persons or fraction thereof.

J. Shower or tub baths shall be provided in the ratio of one for each fifteen (15) persons or fraction thereof.

K. All living quarters, toilets, galleys, and washrooms shall be maintained in a clean and sanitary condition.

L. All mattresses, pillows, and blankets shall be disinfected before being issued to an employee.

M. Clean bed linen and towels shall be provided weekly.

N. A reading light shall be installed at each bunk in crew's quarters of floating plant.

O. Individual clothes lockers shall be provided on floating plant where men are quartered.

P. Heating arrangements capable of maintaining a temperature of 70° in living quarters shall be provided on all floating plant having regular crews or on which men are quartered.

Q. Adequate ventilation shall be provided in living quarters and work areas. Where natural circulation is insufficient, fans or other mechanical ventilation shall be provided.

R. Insect screens shall be provided for all living quarters.

S. Where communicable diseases or vermin are present on floating plant, all such plant or section thereof which have been affected shall be fumigated. The person in charge shall be responsible for the evacuation of all persons in affected areas before starting to fumigate.

T. Warning signs shall be posted at all locations where fumigating is taking place, and such signs shall not be removed or persons permitted to enter until such areas have been properly ventilated and pronounced safe for occupancy by the person in charge.

SECTION 12—MEDICAL SUPPLIES AND FIRST AID 8317.12

A. Floating plant requiring medicine chests under the requirements of the United States Public Health Service shall be so equipped.

B. Floating plant not included in paragraph A, on which men are quartered and which are so located that such supplies and medical attention are not available, shall be provided with necessary quantities of the following:

Alcohol—Cleansing and disinfectant for wounds.

Aspirin or Empirin compound—Use to reduce fever and to relieve headache, rheumatism, or pain in the joints and muscles. Give in doses of 1 to 3 tablets every 4 hours if necessary. Never give more than 12 tablets in 24 hours.

Aromatic spirits of ammonia.

Absorbent cotton, $\frac{1}{4}$ lb. rolls (1st grade).

Adhesive plaster, 2" x 5 yards.

Applicators, 6" wooden.

Brown mixture—20 grain tablet, cough; allow tablet to dissolve on tongue and swallow solution.

Bicarbonate of soda, 5-grain tablets.

Boric acid, powder.

Bandage, 3" x 10 yards.

Belladonna plaster, 7" x 1 yard, in tin cans.

- Castor oil, purgative; 1 to 4 tablespoonfuls.
- Compound cathartic pills, purgative; give 1 to 2 pills.
- Cascara, aromatic, laxative; give 2 teaspoonfuls.
- Tannic acid jelly or Foille—for burns.
- Camphorated oil, $\frac{1}{2}$ pint.
- Dropper, medicine, curved.
- Ear drops, carbolic acid, 1 fluid dram; glycerine, 7 fluid drams.
- Glass, medical, graduated 4 tablespoons to 8 teaspoons.
- Hot water bottle, or electric heating pad where current is available; or thermal heating pad or equal.
- Ice bag.
- Ichthyol ointment, 20 percent, collapsible tube.
- Magnesium sulphate (epsom salts), cathartic; 2 to 4 tablespoonfuls dissolved in water.
- Mercurial ointment (blue ointment)—Used in destroying crab lice and sometimes as a dressing for chronic ulcers. Smear over hairy parts and allow to remain for a day or two, then wash thoroughly with soap and water.
- Milk of bismuth—for relief of diarrhea. Give 1 tablespoonful every two hours until arrested; do not give over four doses.
- Oil of clove—Relieve toothache; apply with absorbent cotton.
- Quinine sulphate, 5-grain tablets or capsules for malaria. Give 10 grains three times daily for three or four days, then 10 grains every night for eight weeks.
- Spray, insecticide liquid.
- Sun cholera mixture, 5 grains.
- Compound methyl salicylate ointment—For rheumatism, sprains and bruises: $\frac{3}{4}$ -oz. tubes and 1-lb. jars.
- Tincture of iodine, 3 $\frac{1}{2}$ % solution; 2-oz. bottles with air-tight caps.
- Thermometer, clinical.
- Tongue depressors, wooden.
- Vaseline, ointment; $\frac{1}{8}$ -lb. jars.
- Zinc oxide—Useful in cases of inflamed, itching or irritated skin; for eruptions of the skin and sunburn.
- Scissors, 4" bandage type.
- Neo-synephrin hydrochloride jelly, $\frac{1}{2}$ % and/or neo-synephrin hydrochloride solution, $\frac{1}{4}$ %; for relief and treatment of head colds.

Sodium chloride (salt) tablets, 10 grains, each; for prevention of heat exhaustion.

Five-percent alcoholic solution of ferric-chloride, 30 percent glycerine; or 10-percent solution of tannic acid in water; for poison ivy, oak and sumac.

Oil of citronella—For mosquito control.

Ten-percent solution of sulphur ointment—For chigger bites.

Cresol—Compound disinfectant for sanitary purposes; used in 1- to 5-percent strength; two teaspoonfuls added to 1 quart of water will make 1-percent solution.

One copy of "The Ship's Medicine Chest and First Aid at Sea," published by the United States Public Health Service, shall be provided.

C. On all floating plant, 16-unit first-aid kits shall be provided in the ratio of one for each 25 persons or fraction thereof and so located as to provide maximum accessibility.

MOTOR VEHICLES

SECTION 01—DEFINITION

8318.01

A motor vehicle, hereinafter referred to as a vehicle, shall mean every self-propelled vehicle used for transporting persons or property except vehicles designed for exclusive use off the highway.

SECTION 02—OPERATOR'S PERMITS

8318.02

A. *Government vehicles.*—Every person regularly or occasionally operating a government motor vehicle shall have passed the prescribed examination and test of the Corps of Engineers and have in his possession at all times while operating such vehicle a Motor Vehicle Operator's Permit, W. D., A. G. O. Form 9-74.

B. *Contractor's vehicles.*—Every person regularly or occasionally operating a contractor's motor vehicle shall have in his possession at all times while operating such vehicle a valid state motor vehicle operator's permit.

SECTION 03—GENERAL

8318.03

A. No vehicle shall be placed in service until it has been inspected by a qualified person and found to be in safe operating condition.

B. All vehicles and their equipment shall be inspected weekly.

C. Vehicles and/or equipment found to be in unsafe operating

condition shall be removed from service, repaired or replaced, and reinspected before being placed in service again.

D. Current records of all inspections shall be kept on file and be available for review.

E. No operator shall be permitted to operate a motor vehicle for more than ten (10) hours in any one day or more than sixty (60) hours in any one week. Exceptions to this regulation will only be made under authorization of the Division, District or Area Engineers or Commanding Officer of Independent Establishments.

SECTION 04—EQUIPMENT

8318.04

A. All vehicles or combination of vehicles, except motorcycles, shall be equipped with at least the following lights:

1. Two headlights; one on either side.
2. One red taillight and one red or amber stop light.

B. Motorcycles shall be equipped with one headlight and one red tail lamp.

C. All lamps required to be securely and permanently affixed to any vehicle shall be electric.

D. Every vehicle or combination of vehicles, except trailers with a gross weight of less than 3000 pounds, shall be equipped with brakes on each of the vehicles adequate to control the movement and to stop and to hold such vehicle or combination of vehicles under all conditions of service.

E. Braking systems on every combination of vehicles shall be so designed as to be in approximate synchronism on all wheels and developing the required braking effort on the rearmost wheels first. Such design shall also provide for application of the brakes by the driver of the towing vehicle from his cab.

F. Braking systems on all combinations of vehicles shall be so designed and connected that in case of accidental break-away of the towed vehicle the brakes shall be automatically applied and application continued for a period of not less than fifteen (15) minutes.

G. Every vehicle or combination of motor vehicles shall be capable at all times and under all conditions of being stopped on a dry, smooth, level road upon application of the service brake within the distances specified below.

*Stopping Distance
at 20 M. P. H. (feet)*

Vehicles or combinations of vehicles having brakes on all wheels -----	30
Vehicles or combinations of vehicles not having brakes on all wheels -----	45

H. Every vehicle shall be equipped with a speedometer in proper operating condition.

I. Every vehicle shall be equipped with an adequate warning device in proper operating condition.

J. Every vehicle shall be equipped with a suitable windshield wiper.

K. In localities where weather requires, every vehicle shall be equipped with a suitable defrosting device.

L. All vehicles shall be equipped with a rear view mirror so arranged to give a clear view of the highway to the rear.

M. Suitable cabs, cab shields and other necessary protection shall be provided on all vehicles to protect the driver from the elements, falling materials, etc.

N. Non-slip surfaces shall be provided on running boards and steps of all vehicles.

O. All glass used in windshields, windows and doors of vehicles shall be "safety glass".

P. All towing devices used on any combination of vehicles shall be designed by the manufacturer of such equipment and shall be structurally adequate for the weight drawn and securely and properly mounted.

Q. A locking device shall be provided on every fifth wheel mechanism and tow bar arrangement which will prevent the accidental separation of towed and towing vehicles.

R. Every full trailer shall be coupled with safety chains or cables to the towing vehicle. Such chain or cable shall be adequate to prevent the separation of the vehicles in the event of failure of the tow bar.

S. All dump trucks shall be equipped with hinged struts permanently attached and capable of being locked in the raised position or other similar device to prevent accidental lowering of the body.

T. All operating levers on hoists shall be equipped with a latch or other device which will prevent accidental starting or tripping of the mechanism.

U. Trip handles for tail gates on all dump trucks shall be so arranged that load may be dumped from the cab of truck.

V. Tail gates of dump trucks shall be equipped with D handles or other similar arrangement for handling.

W. All vehicles except motorcycles shall be equipped with a power operated starting device. Cranks shall be used only in case of failure of power operated starting device or while making motor adjustments.

X. All vehicles shall be equipped with the following emergency equipment:

1. One spare bulb for each type used.
2. One spare fuse for each type used.

Y. All buses, trucks and combinations of vehicles with a carrying capacity of one and one-half tons or over shall be equipped with the following emergency equipment:

1. One carbon tetrachloride or carbon dioxide fire extinguisher.
2. One red flag not less than 12 inches square and one red lantern for day or night use on projecting load.
3. Two wheel chocks for each vehicle or each unit of a combination of vehicles.
4. Two red flags not less than 12 inches square with standards, and three flares or three red lanterns which shall be available for immediate use in case of emergency stops.

SECTION 05—OPERATING RULES

8318.05

A. No vehicle shall be driven at a speed greater than is reasonable and proper having due regard to weather, traffic, intersections, width and character of the roadway, type of motor vehicle and any other existing conditions. The operator must at all times have the vehicle under such control as to be able to bring it to a complete stop within the assured clear distance ahead.

B. No vehicle shall be driven in or through any state, legal subdivision thereof, the District of Columbia or any area under the control of the Federal Government at a speed greater than that permitted by such state, legal subdivision, District of Columbia or the Federal Government.

In any event speeds will not be permitted in excess of the following:

1. In a business or residential district, twenty-five (25) miles per hour.

2. At other locations fifty (50) miles per hour during the daytime and forty-five (45) miles per hour at night.

C. Headlight beams will be depressed when approaching other vehicles.

D. Traffic signs and signals will be obeyed at all times.

E. Every vehicle shall be driven as far to the right side of the traveled portion of the highway as practicable.

F. No vehicle shall be driven on a down-grade with gears in neutral or clutch disengaged.

G. No vehicle shall pass another vehicle going in the same direction on turns, curves or the crest of a hill unless there exists 500 feet of unobscured vision. This limitation shall not apply on a one-way roadway.

H. Vehicles shall not proceed on any road, street or highway in a direction opposite to that prescribed for traffic movement.

I. Every vehicle upon approaching a railroad crossing or drawbridge shall be driven at such a speed as to permit stopping before reaching the nearest track or the edge of the draw and shall proceed only if the course is clear.

J. No vehicle shall be stopped, parked or left standing on any highway or adjacent thereto in such a manner as to endanger other vehicles using such highway.

K. No vehicle shall be left unattended until after the motor has been shut off, the key removed, the parking brake securely set and all other reasonable precautions have been taken to prevent its movement.

L. All vehicles carrying loads which project more than four (4) feet beyond the vehicle will at night, or whenever atmospheric conditions are such that it is necessary, carry a red light at or near the end of the projection. At other times a red flag not less than twelve (12) inches square shall be used.

M. Employees shall not be permitted to get between a towed and towing vehicle until both vehicles have been stopped and, where necessary, wheels securely chocked.

N. Every vehicle or combination of vehicles except station wagons and passenger cars shall have posted on the side of said vehicle, in letters not less than two (2) inches high, the weight and rated capacity of such vehicle.

EXAMPLE—Wt. 4600 lbs. Rat. Cap. 6000 lbs.

O. No vehicle or combination of vehicles hauling unusually heavy loads or equipment shall be moved until the driver has been provided with the correct weights of the vehicles and load and a designated route to be followed.

P. The operators of vehicles shall make certain that the way is clear before backing or maneuvering except when directed by a qualified signalman.

Q. Operators of vehicles, except passenger cars, transporting personnel, explosives, flammables or toxic substances shall come to a full stop at railroad crossings or drawbridges and shall not proceed until the course is clear; providing, however, that a full stop shall not be required at a streetcar crossing within a business or residential district nor at a railroad grade crossing or drawbridge protected by a watchman or traffic officer on duty or by a traffic signal giving a positive indication to approaching vehicles to proceed.

R. When a bus, truck, or truck-trailer combination is disabled on the traveled portion of a highway or the shoulder adjacent thereto, except in the business or residential section of a municipality, the red flags shall be displayed during the daytime and the flares or electric lights at night or when atmospheric conditions are such that red flags are not clearly visible for at least 500 feet. One flag or flare shall be placed at least 200 feet to the front and rear of the vehicle. The third flare or electric lantern shall be placed at the traffic side of the vehicle. In connection with vehicles transporting flammables or explosives only electric lanterns shall be used.

S. Windshields shall be maintained in such condition as to provide maximum visibility.

SECTION 06—TRANSPORTING PERSONNEL

8318.06

A. Trucks transporting personnel shall not be operated at a speed greater than thirty (30) miles per hour.

B. Trucks being used to transport personnel shall be equipped with a seating arrangement securely anchored and a rear end gate or guardrail.

C. Bodies of dump trucks shall be made fast to chassis while being used to transport personnel. They shall be securely fastened by a rope, chain or equivalent in addition to the normal locking device.

D. All tools and equipment shall be properly stowed and securely fastened when transported with personnel.

E. Under no circumstances shall any person be permitted to ride with arms or legs outside of truck body, in a standing position on the body, or on running boards nor seated on side fenders, cabs, cab shields, rear of truck or on the load.

F. Getting on or off any vehicle while it is in motion is prohibited.

G. Steps or ladders shall be provided for getting on and off trucks.

H. All vehicles transporting personnel during cold or inclement weather shall be provided with tarpaulins or other suitable enclosures.

I. No explosives, flammables or toxic substances shall be transported in vehicles while carrying personnel.

J. No vehicle transporting personnel shall be moved until the driver has ascertained that all persons are seated and the required guardrails and rear end gates are in place.

SECTION 07—FUELING

8318.07

A. No vehicle shall be fueled while the motor is running.

B. Fueling of vehicles shall not be permitted in the immediate vicinity of smoking, open flames or other sources of ignition.

C. Vehicles shall not be fueled inside of closed buildings.

D. All tanks, containers and fuel hoses shall be kept in metallic contact while fueling.

E. Fuel supplies shall be carried in properly constructed and mounted fuel tanks except that this provision shall not be construed to prohibit use of liquid fuel gases from a properly constructed cargo tank.

F. Filler openings for fuel tanks shall not be located inside the body or cab of any vehicle, or in such position that spills or overflow can run down on motor, exhaust pipe or battery.

G. All vehicles shall be equipped with a fuel gauge maintained in operating condition.

SECTION 08—LOADING

8318.08

A. No vehicle shall be so loaded as to obscure the driver's view ahead or to either side or to interfere in any manner with the safe operation of such vehicle.

B. No part of the load will extend beyond the sides of the vehicle.

C. The load on every vehicle shall be properly distributed, chocked, tied down or otherwise secured in order to prevent shifting.

D. No vehicle shall be driven with a load overhanging the rear until proper warning flags or lights are in place and the driver has ascertained that required vehicle lights or reflectors are not obscured by tailboard, tailgate, or load.

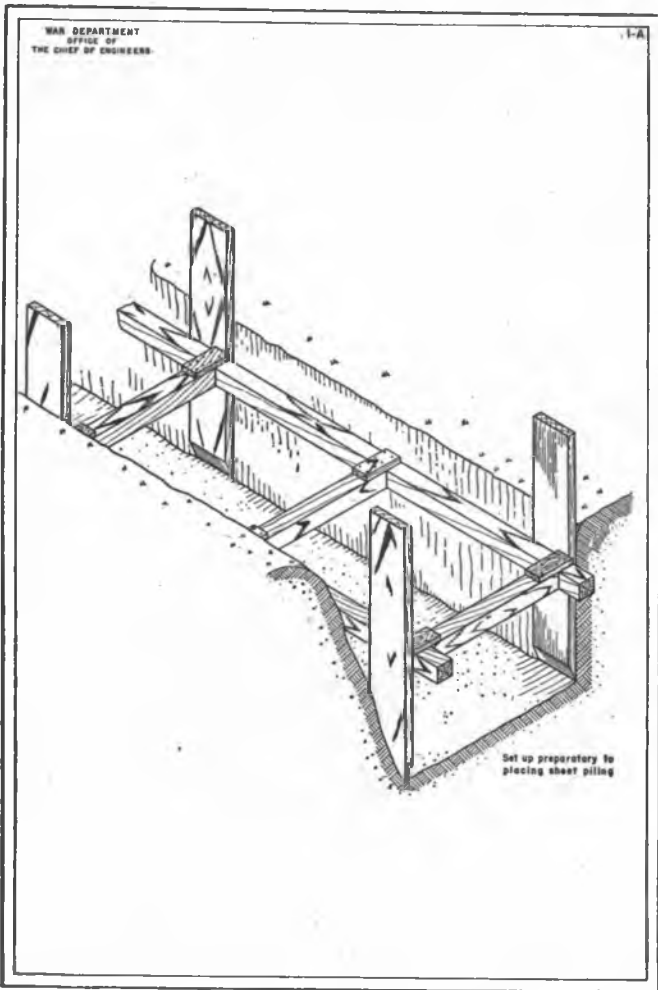

FIGURE 1.—Position of walers before placing sheet piling for shoring trenches.

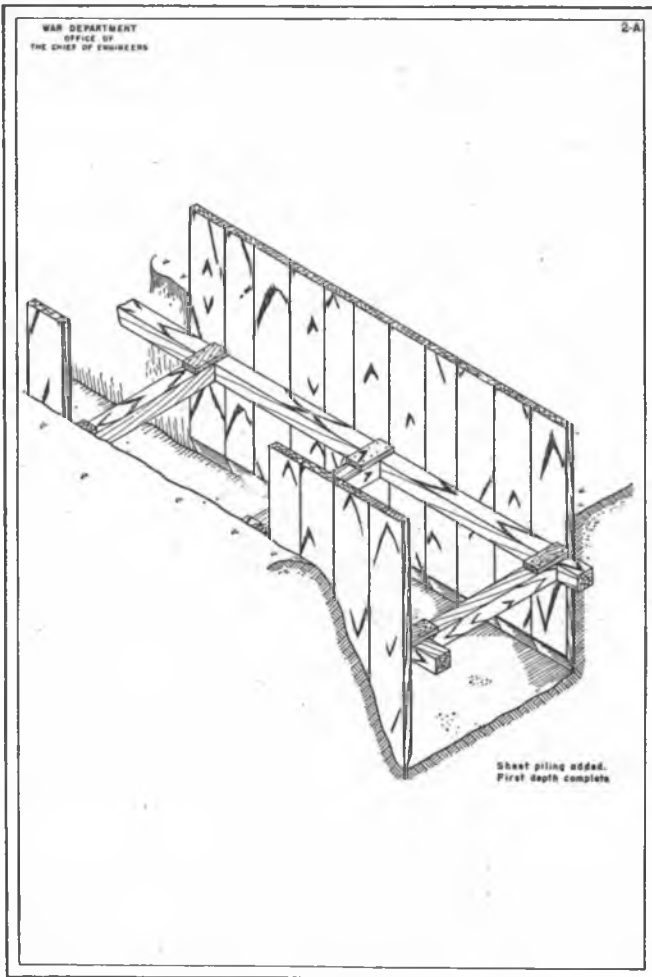

FIGURE 2.—Illustrating completion of first depth in trench shoring.

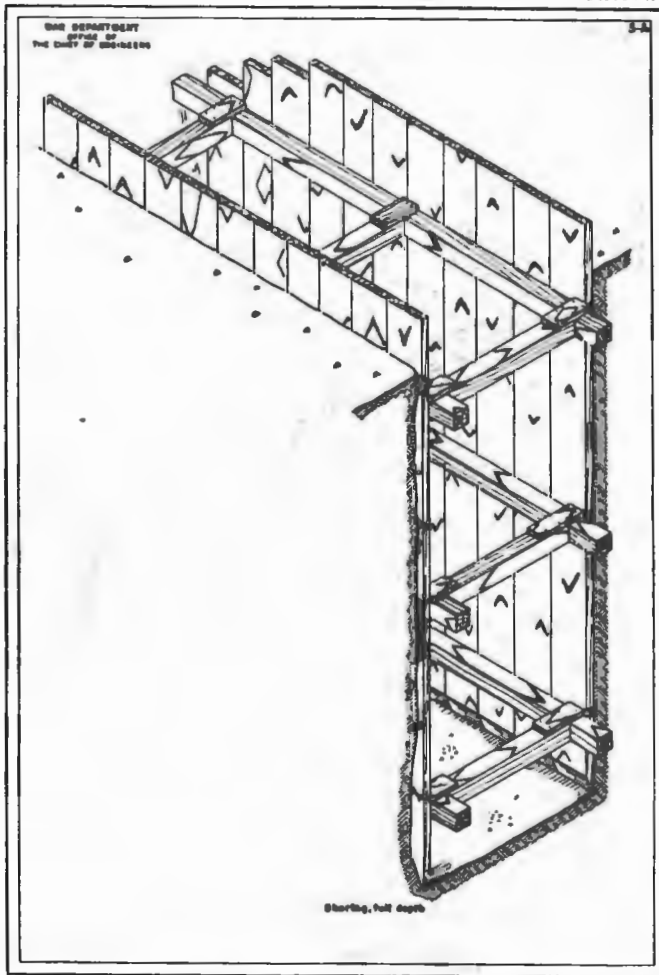
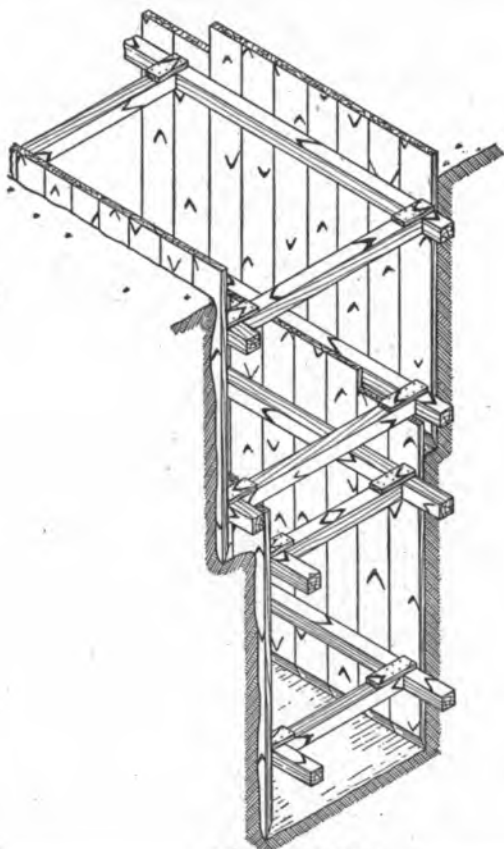

FIGURE 3.—Trench shoring completed for full depth, single length of sheeting.



Method of bracing when two lengths
of sheet piling are used.

FIGURE 4.—Method of shoring trench using two lengths of sheeting.

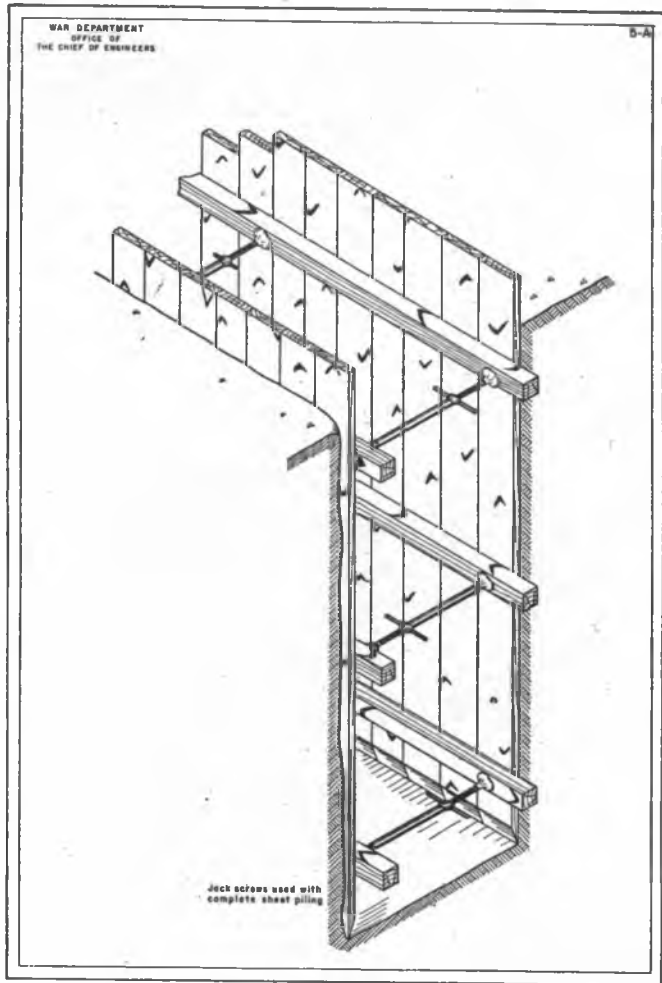

FIGURE 5.—Substituting trench jacks for cross braces used in trench shoring.

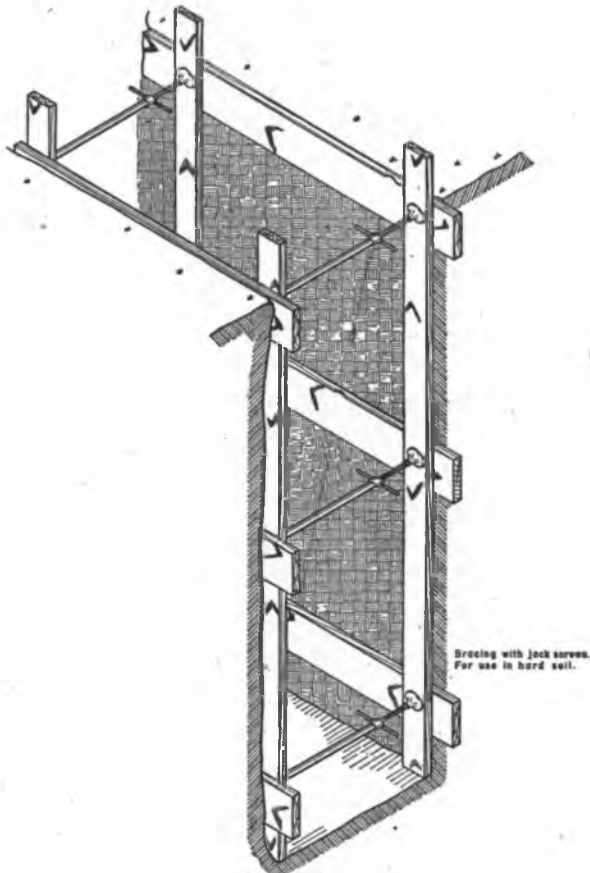

FIGURE 6.—Illustrating trench jacks used to brace horizontal and vertical planks bearing against hard compact material.

WAR DEPARTMENT
OFFICE OF
THE CHIEF OF ENGINEERS



SAFETY EMBLEM
BY PERMISSION OF
NATIONAL SAFETY
COUNCIL.

INSERT APPROPRIATE NAME HERE:
INFIRMARY OR FIRST AID STATION

SPECIFICATIONS

COLOR: DARK GREEN LETTERS, FIELD
AND BORDER ON WHITE BACKGROUND.
DO NOT LETTER WITHIN CROSS

MATERIAL: WOOD, PLYWOOD, OIL -
CLOTH, ETC. (OPTIONAL)

INSIGNIA SHOULD BE PAINTED ON
BOTH SIDES OF MATERIAL WHEN
PLACED UPON ROOF...FLOOD LIGHT
OR OTHERWISE ILLUMINATE FOR
NIGHT OPERATION.

FIGURE 7.—Standard insignia for Infirmary and First-Aid
Stations.

WAR DEPARTMENT
OFFICE OF
THE CHIEF OF ENGINEERS

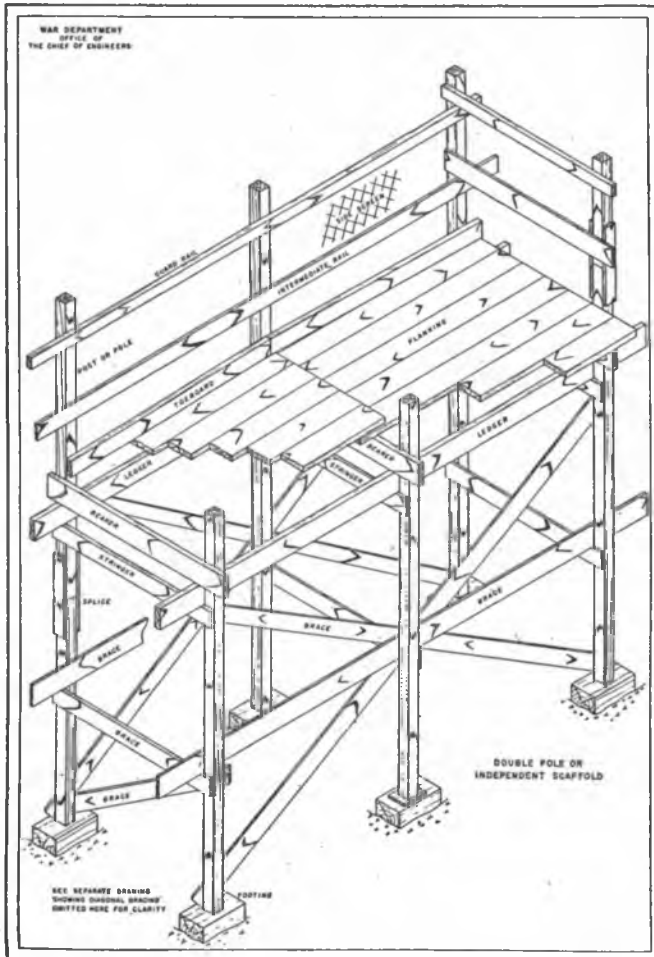

FIGURE 8.—Construction of double pole or independent scaffold.

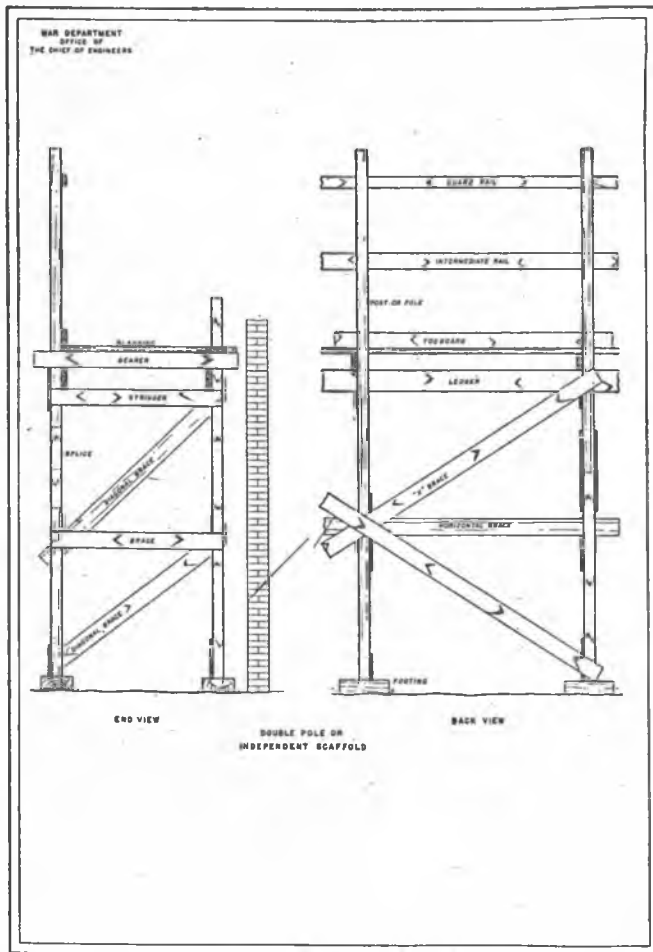

FIGURE 9.—Illustrating diagonal bracing on double pole scaffold.

WAR DEPARTMENT
OFFICE OF
THE CHIEF OF ENGINEERS

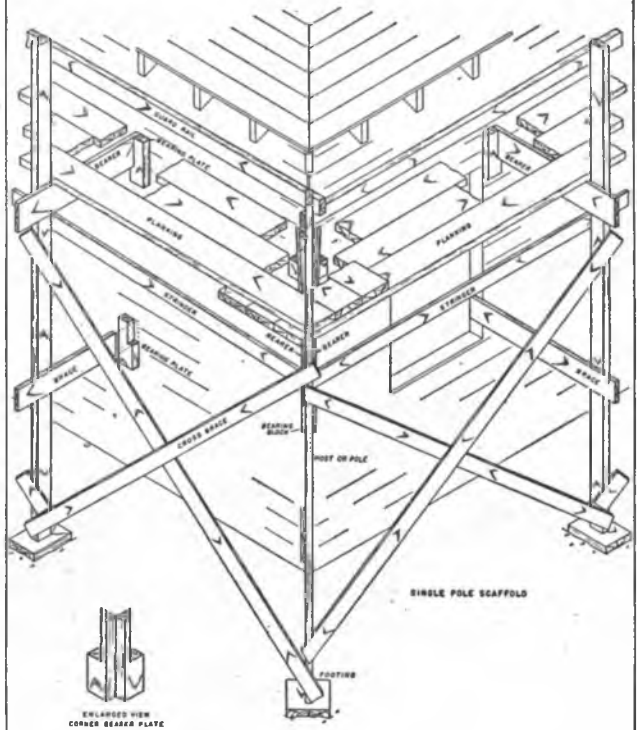

FIGURE 10.—Illustration of corner construction of single pole scaffold.

WAR DEPARTMENT
OFFICE OF
THE CHIEF OF ENGINEERS

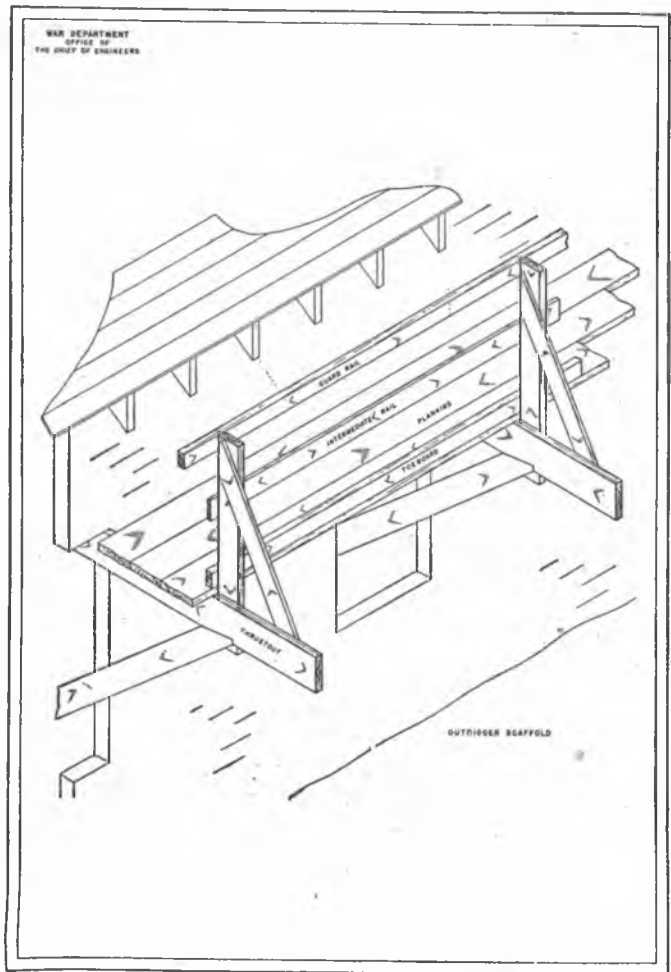
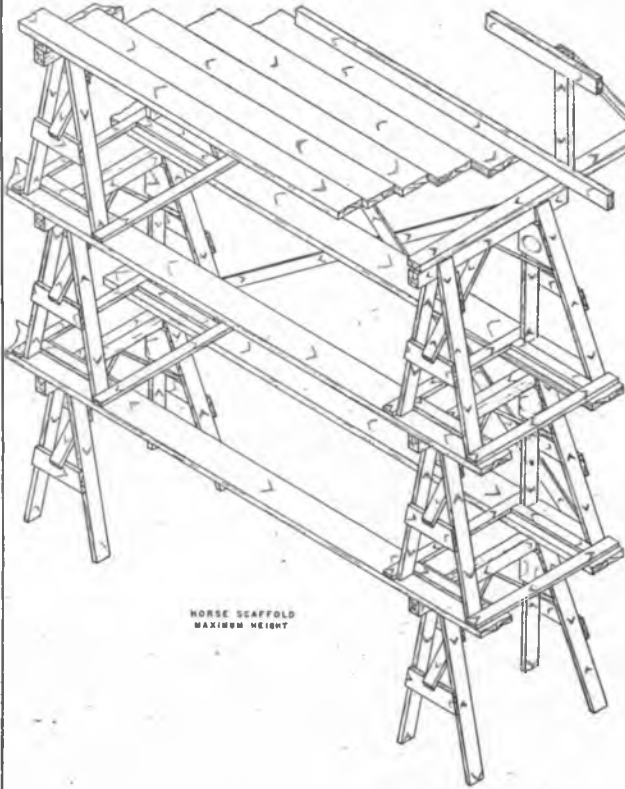

FIGURE 11.—Construction of outrigger scaffold with guardrail and toeboard.

WAR DEPARTMENT
OFFICE OF
THE CHIEF OF ENGINEERS



HORSE SCAFFOLD
MAXIMUM HEIGHT

FIGURE 12.—Illustrating maximum height of horse scaffold, 3 tiers or 16 feet.

WAR DEPARTMENT
OFFICE OF
THE CHIEF OF ENGINEERS

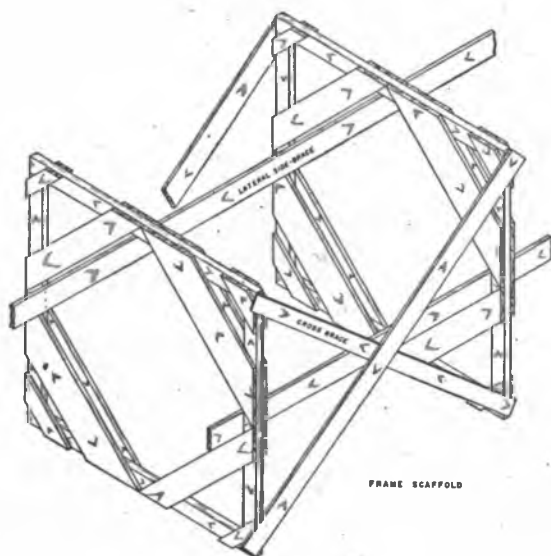
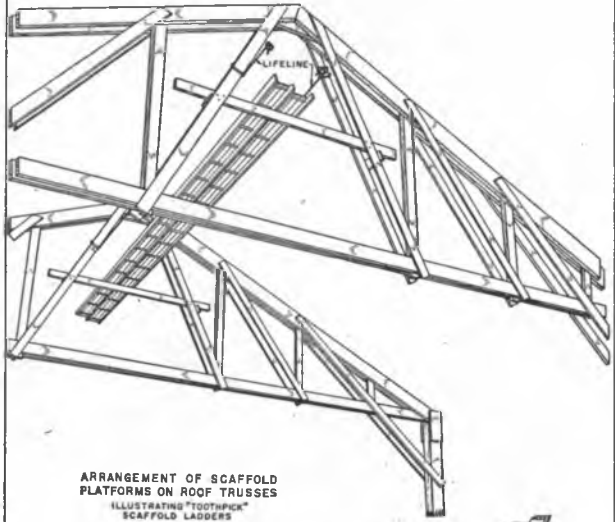
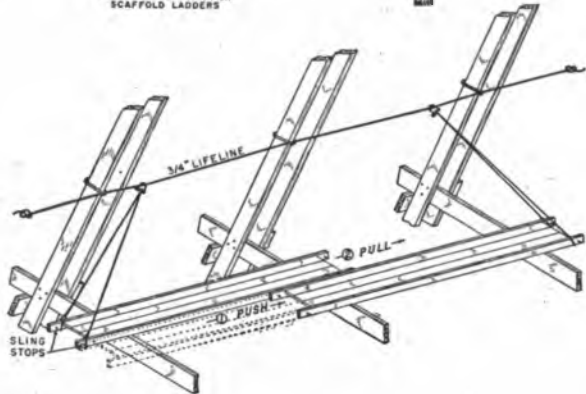

FIGURE 13.—Showing construction of the square or frame scaffold.

WAR DEPARTMENT
OFFICE OF
THE CHIEF OF ENGINEERS



ARRANGEMENT OF SCAFFOLD
PLATFORMS ON ROOF TRUSSES
ILLUSTRATING "TOOTHPICK"
SCAFFOLD LADDERS



ILLUSTRATING USE OF LIFELINE
FOR MOVING SCAFFOLD PLATFORMS

FIGURE 15.—Portable "toothpick" scaffolds used on roof trusses.
Illustrating use of lifeline.

WAR DEPARTMENT
OFFICE OF
THE CHIEF OF ENGINEERS

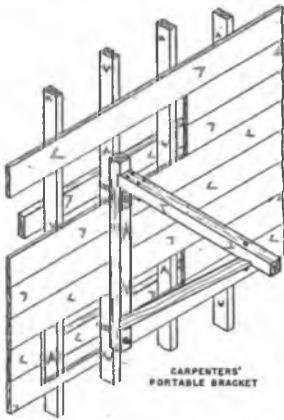

CARPENTERS'
PORTABLE BRACKET



LADDER JACK

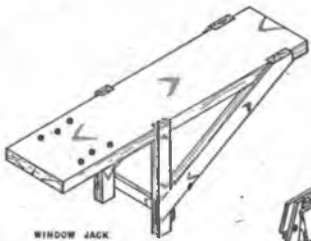

WINDOW JACK



HINGED
FRAME HORSE

FIGURE 16.—Carpenter's portable bracket, ladder jack, window jack, and hinged frame horse.

WAR DEPARTMENT
OFFICE OF
THE CHIEF OF ENGINEERS

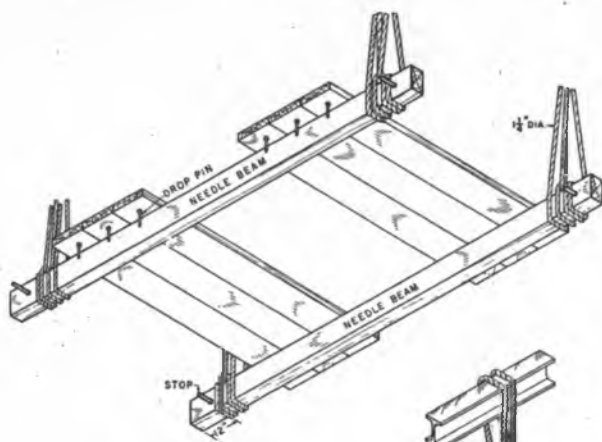

NEEDLE BEAM SCAFFOLD

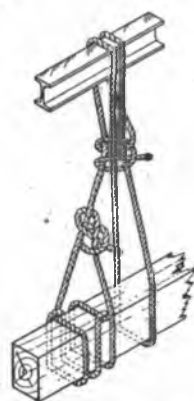

ENLARGED VIEW
SCAFFOLD HITCH
AND FASTENING

FIGURE 17.—Needle beam scaffold with fastenings.

WAR DEPARTMENT
OFFICE OF
THE CHIEF OF ENGINEERS

SINGLE RUNG TYPE LADDER

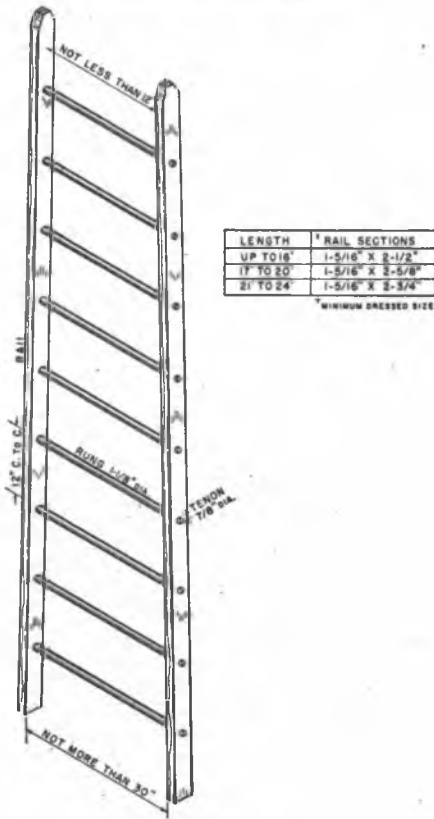
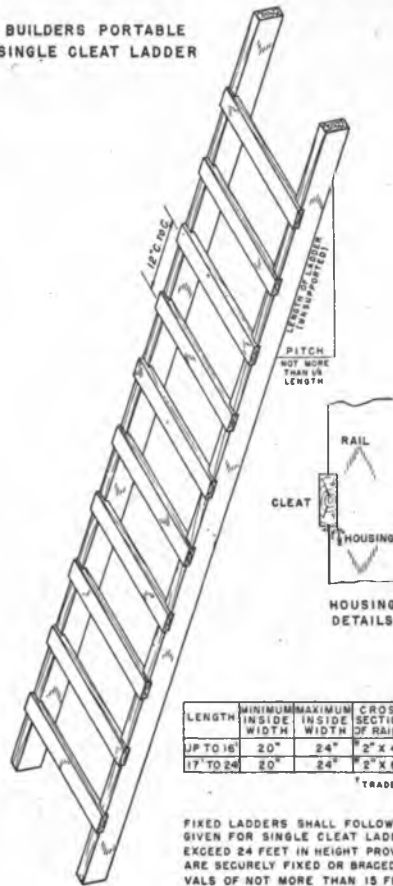

FIGURE 18.—Single rung type ladder.

BUILDERS PORTABLE
SINGLE CLEAT LADDER



LENGTH	MINIMUM INSIDE WIDTH	MAXIMUM INSIDE WIDTH	CROSS SECTION OF RAILS	CROSS SECTION OF CLEATS
UP TO 16'	20"	24"	2" X 4"	1" X 3"
17' TO 24'	20"	24"	2" X 6"	1" X 4"

*TRADE SIZES

FIXED LADDERS SHALL FOLLOW DIMENSIONS GIVEN FOR SINGLE CLEAT LADDERS AND MAY EXCEED 24 FEET IN HEIGHT PROVIDED THEY ARE SECURELY FIXED OR BRACED AT INTERVALS OF NOT MORE THAN 15 FEET.

FIGURE 19.—Portable single cleat ladder.

WAR DEPARTMENT
OFFICE OF
THE CHIEF OF ENGINEERS



WHIPPING-STEP 1
ROUNDS OPENED TO CLARIFY



WHIPPING-STEP 2
PULL LOOP TO CENTER



WHIPPING
CORRECT PROCEDURE

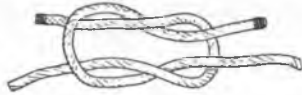

SQUARE KNOT



SHEET BEND



BOWLINE

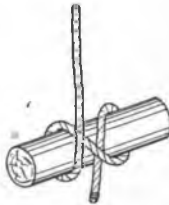

CLOVE HITCH



ROLLING HITCH



RUNNING
BOWLINE

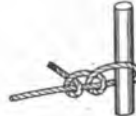

TWO HALF
HITCHES



ROUND TURN AND
TWO HALF HITCHES



TIMBER HITCH
AND
HALF HITCH



SCAFFOLD
HITCH

FIGURE 20.—General types of knots and hitches used in construction.

~~SECRET~~ FLUORINE

PRECAUTIONS TO BE OBSERVED IN HANDLING, SHIPPING AND STORAGE

1. Properties

1.01 Fluorine is the most active of all the elements. It reacts with all organic and nearly all inorganic materials at ordinary or slightly elevated temperatures. Even gold and platinum are converted into fluorides at temperatures between 300 and 400°C. The only substances that are completely resistant are the pure inert gases and the completely saturated fluorides. Hydrogen and fluorine react with explosive violence at ordinary temperatures. Oxygen, chlorine, nitrogen and argon do not unite directly with fluorine. With water, fluorine forms hydrofluoric acid and ozone. Dry fluorine attacks glass slowly but in the presence of moisture, glass is rapidly destroyed.

1.02 At the critical temperature, -155°C (-247°F), the gas fluorine may be liquified under the critical pressure of 25 atmospheres (368 psi). In concentrated form, the gas is greenish-yellow. The liquid may be frozen by further cooling, forming white crystals which melt at -233°C (-387°F). The liquid boils at -187°C (-305°F). In concentrated gaseous form, contact with organic material of any kind will result in liberation of large quantities of heat and elevation of temperature. This is also true of most inorganic substances. Degree of concentration and temperature are modifying factors. Copper and nickel are acted upon at ordinary temperatures, protective coatings of the fluorides being formed if speed of reaction is controlled.

2. Physiological Effects of Contact

2.01 Burns - A jet of fluorine from a pressure container will react with human flesh and can cause extremely severe burns that are very difficult to heal. Tissue destruction takes place in three separate ways:

- (a) Destructive oxidation by fluorine
- (b) Thermal damage from the heat of reaction
- (c) Tissue poisoning by HF formed

All three types of damage occur very rapidly upon exposure to undiluted fluorine when impinged on a surface from a source under pressure. There is some degree of dilution below which the first and second do not take place to any significant extent, but the exact value of this dilution has not been ascertained. The third type of damage takes place in concentrations much lower than the first two, because HF is formed by the reaction of fluorine with moisture on the skin. HF is a protoplasmic

~~SECRET~~

~~SECRET~~

poison with great penetrating power and causes deep-seated burns that heal very slowly.

When a jet of pure fluorine strikes most non-metallic materials, the surface of the material is instantly raised to an incandescent white heat. Personnel in the vicinity may be severely burned by heat radiated from the surface even when they are not directly exposed to fluorine at all.

2.02 Respiratory Damage - Fluorine is an irritant gas the toxicity of which is approximately that of phosgene. Exposure to dilute fluorine results immediately in irritation of the eyes, nasal passages, and throat. Next, the skin becomes moist and then the front of the head begins to ache. The maximum allowable safe exposure occurs somewhere between the development of the last two symptoms.

Toxicity:

Minimum detectable by odor	3 p.p.m.
Maximum allowable for long exposure	3 p.p.m.
Immediately irritating (tolerable for several minutes)	25 p.p.m.
Intolerable even for short exposure	50 p.p.m.

3. Precautions

3.01 NO PERSONAL PROTECTIVE EQUIPMENT HAS BEEN DEvised TO DATE WHICH WILL RELIABLY AFFORD EVEN TEMPORARY PROTECTION AGAINST A HIGH PRESSURE JET OF PURE FLUORINE.

3.02 All valves and equipment handling fluorine under pressure shall be operated wherever possible by extension handles through brick barricades or metal shields.

3.03 Openings into fluorine lines or equipment shall be sealed off from any possible source of fluorine pressure by two valves, preferably with a nitrogen buffer zone between valves.

3.04 Before any line or equipment which has contained fluorine is opened, it shall be vented and thoroughly purged with nitrogen.

3.05 Since there is no immediate means of controlling or determining degree of concentration in the breathing zone, the breathing of fluorine contaminated air should be avoided. (See par. 3.09.)

3.06 Salts of fluorine collect on the inside of pipes, valves, and other equipment as a fine powder. Inhalation or ingestion of these

~~SECRET~~

~~SECRET~~

salts is extremely dangerous and every precaution should be taken to avoid breathing or swallowing them. (See par. 4.02.)

3.07 No welding or hot work shall be done on or adjacent to lines or equipment containing fluorine.

3.08 The interior of all lines and equipment for handling fluorine must be kept perfectly clean and free from moisture, grease or foreign material of any kind.

3.09 Leakage may usually be detected by the characteristically pungent odor. The least evidence of irritation of eyes, or nose and throat, should be regarded as positive warning of contamination above the toxic limits and the area immediately evacuated. No contaminated areas shall be entered except by selected personnel until such areas have been completely purged of fluorine. Only trained personnel, properly equipped with personal protective devices and clothing, shall enter, and no person shall enter an inclosed contaminated area out of sight of other personnel who are properly clothed for emergency rescue work. No connections shall be made or broken in fluorine lines except by trained personnel wearing suitable protective devices.

3.10 All persons authorized to make or break connections or to enter contaminated areas, shall have had thorough instruction and training. They shall at all times use all possible precautions, taking care to keep at arms length whenever possible. In operating the Kerotest valve on cylinders, the operator shall stand out of line of any possible discharge from the valve.

3.11 In the event of a leak at a cylinder valve, the valve should be closed, and the temperature of the cylinder should be reduced as quickly as possible. If the leak is of such magnitude or of such nature that it cannot be immediately stopped, the area should be cleared of personnel and only re-entered by trained personnel, properly equipped and under the direction of the ranking supervisors.

3.12 All tools, protective clothing and devices used shall be thoroughly cleaned after use. Care should be exercised to insure neutralization and removal of any acid or salt which may be deposited during operations. Tools used shall be washed in a 3% soda ash solution and thoroughly rinsed in clean water.

3.13 It is strongly recommended that the use of pressures above 30 psi be avoided, if at all possible. The hazard of handling and shipping fluorine under high pressures is so greatly increased that consideration of cost or convenience is not warranted.

~~SECRET~~

4. Protective Equipment

4.01 It should be constantly borne in mind by all personnel working with fluorine that there is no personal protective equipment which can be relied upon to give even temporary protection against a direct exposure to a jet of pure fluorine. Temporary protection against contaminated areas, and the residual gases and dust which may be encountered in connecting and disconnecting purged lines, will be afforded by the following:

4.02 Persons operating pressured fluorine valves, who are not protected by barriers, or who are connecting or disconnecting purged lines or equipment, shall be protected by coveralls (Unimpregnated special protective clothing - TM3-290 W. C. Miscellaneous Gas Protective Equipment, P. 7 and 8), face shield and gauntlet neoprene gloves for pressures up to 15 psi. Above 15 psi, U. S. Army Combat Mask M5 shall be substituted for the face shield. All equipment must be clean and free from grease or oil.

4.03 Persons entering contaminated areas where breathing is restricted by fluorine and there is no deficiency of oxygen shall be protected by U. S. Army Combat Mask M5, in place of face shield, and rubber or neoprene boots. Other personal protection same as above (4.02).

4.04 Persons entering contaminated areas where an oxygen deficiency exists and for cases of rescue work - Bureau of Mines approved oxygen breathing apparatus, in place of face shield, and rubber or neoprene boots. Other personal protection same as above (4.02).

5. Shipment and Storage

5.01 Fluorine is shipped by Government trucks in clean, dry, stainless steel containers, identified by yellow bands with black stripes. The containers are tagged by the shipper with the pressure and net weight.

5.02 Containers arrive with a protective cap on the large valve, which cap is suitably vented. In addition, there is a small cap which protects the threads on the cylinder valve outlet. This cap does not have a vent since it serves as a protection in case a leak should develop between the valve seat and stem while in transit. The latter cap should be opened, preferably out of doors, using a wrench with a metal shield so constructed or arranged to prevent any gas from leaking around the threads and spraying the operator. In the event of continued escape of gas, operators should stop all operations until it is certain that leakage can be safely handled.

5.03 Bulk storage of low pressure fluorine, or any storage of high pressure containers, should be located out of doors or in a fire resistant building. Storage yards and buildings shall be restricted areas

~~SECRET~~

~~SECRET~~

and shall be detached from other buildings. No spacing is necessary between containers in storage. Storage buildings shall have good natural ventilation and shall have mechanical ventilation of sufficient capacity to change the air 10 times per hour. The mechanical ventilation shall be in operation before anyone may enter the storage building.

6. Emergency First Aid

6.01 In any locality where fluorine is handled, it is important to know where competent medical assistance may be secured with the least possible delay. It is also important that the physician be informed that he may be called upon to treat fluorine burns in order that he may be properly prepared for emergency treatment.

6.02 Means for obtaining large quantities of water without delay should be provided. In any locality where fluorine is used frequently or in quantity, emergency drenching showers must be provided.

6.03 Provide a $\frac{1}{2}$ gallon bottle of 25% magnesium sulphate and a suitable place to keep it, where it may be secured without delay.

6.04 It is important that even very small burns be given IMMEDIATE treatment.

- (a) In the event of skin contact with fluorine flush with copious quantities of tap water.
- (b) Remove contaminated clothing.
- (c) Continue flushing of the skin with tap water for at least 15 minutes. It is of the utmost importance that flushing start at the earliest possible moment after contact and that copious amounts of water be used.
- (d) Soak injured area in 25% magnesium sulphate solution or place compresses of magnesium sulphate over the injured area and keep them moist. Never rupture vesicles or blisters that may form. Any breaks or cuts in the skin may lead to secondary infection.
- (e) After flushing the injured area thoroughly, get the patient to a physician without further delay.

Prepared by:
Safety and Accident Prevention Branch
Approved by:
Medical Division
Manhattan District
U. S. Engineer Department
14 June 1946.

Revised and declassified
23 August 1946.

~~SECRET~~

~~SECRET~~

Reaction of Fluorine with Various Substances.

<u>Material</u>	<u>Concentration of Fluorine</u>	<u>Temperature</u>	<u>Reaction</u>
Water	100%	Normal	Vigorous, much heat, HF formed
Hydrogen	Wide range	Normal	Spontaneously explosive HF formed
Organic - human flesh, wood, rubber, neoprene, cloth, oil, etc.	100%	Normal	Burst instantly into vigorous flame, HF formed. (Smooth neoprene surfaces, when perfectly clean, are resistant to reaction)
	50%	Normal	Rapid oxidation, HF formed, heat generated, flames if heat is not conducted away rapidly
Inorganic - brick, concrete, stone, asbestos, etc.	60% to 100%	Normal	Instantly reaches incandescent temperature
Metallic - steel, nickel, monel, copper, brass, aluminum	100%	Normal	Slow, satisfactorily resistant
	100%	300°F	Burst into flame, intense heat (heat to initiate reaction may come from oxidation of oil, water, etc.)
	60%	Elevated	This is approximately the lower limit of concentration for vigorous reaction
C8F16 and C7F16			Forms explosive mixtures

~~SECRET~~

~~SECRET~~

<u>Material</u>	<u>Concentration of Fluorine</u>	<u>Temperature</u>	<u>Reaction</u>
Fluorolube Oils	Greater than 6%	Operating	Forms polymerized products. Will burn in 100% Fluorine under certain conditions. Forms explosive mixtures under certain conditions.
Polytetrafluoroethylene plus CaF ₂	100%	Operating temperatures	Normally satisfactorily resistant. Will burn under certain conditions.

~~SECRET~~

~~SECRET~~

LEAD

Precautions to be Observed in Handling,
Shipping and Storage.

1. Properties.

1.01 Lead (Pb) is a soft, bluish-white metal extensively used in industry. It occurs in nature chiefly as the sulphide, galena (PbS).

1.02 Lead has a density of 1134 grams per cubic centimeter, a melting point at 327.4°C (621°F), and a boiling point at 1613°C (2935°F). Molten lead surfaces rapidly oxidize when exposed to the air and minute particles are carried off by air currents, thus contaminating the surrounding atmosphere. It is, therefore, important that operations involving handling molten lead, or its alloys, be controlled by adequate exhaust. Contamination of air in excess of the toxic limit of 1.5 mg. per 10 cubic meters of air may lead to chronic lead poisoning.

2. Physiological.

The symptoms and clinical signs of chronic lead poisoning are not distinctive, particularly in the early stages. Any case involving a history of exposure to lead should be referred to a competent physician with information regarding the time and extent of exposure. It is also of importance that complaints of ill health on the part of workers be given serious attention and be promptly referred to a physician.

Such symptoms as disturbances of digestion, muscular pain, weakness, and pallor may indicate lead absorption or may result from other causes of disability. However, such symptoms are not a measure of the degree of absorption, and damage may be greater than early symptoms would indicate. Diagnosis and treatment in the early stages may avert serious consequences. Advanced stages may be characterized by such symptoms and signs as abdominal pains (colic), blue line on gums, paralysis of the extensor muscles of forearm and hands (wrist drop), presence of lead in urine, reduced hemoglobin count and the presence of basophilic granulations in the blood picture. The resistance of individuals and the symptoms vary over a wide range.

While the above information is of interest to laymen responsible for the safety of workers exposed to lead, it should be borne in mind that the diagnosis and treatment of lead poisoning is strictly the business of the physician and any cases of suspected disability among workers in lead should be referred to him with a complete history of exposure.

~~SECRET~~

CS-5e
CS-4B

3. Precautions.

3.01 Safety shoes and gloves should be worn when handling cast lead in the form of blocks or pigs.

3.02 Face shields and gloves should be worn when melting and casting lead.

3.03 Melting pots and every process creating dust should be equipped with mechanical exhaust, which will effectively remove any fumes or dust at the point of origin. Care should be exercised in the design and installation of exhaust equipment to insure an adequate movement of air from the worker toward the process and out through the exhaust to the open atmosphere. Ample general ventilation should be provided for the workroom.

3.04 It is important that good order and cleanliness be observed wherever lead is used in quantity. Benches and structural surfaces should be cleaned frequently, preferably with a vacuum cleaner. Dry sweeping should be prohibited.

3.05 Ample washing facilities should be provided and workers instructed in the necessity for careful observance of personal hygiene. No employee should be permitted to leave for lunch or at the end of shift without first thoroughly washing exposed parts of the body. Work clothing should be provided and each individual be assigned separate lockers for work clothing and street clothing. All should be urged to take a shower before leaving at the end of the shift. Work clothing should be laundered at frequent intervals.

3.06 No food should be kept nor eaten in work spaces where lead is processed or fabricated. Smoking and chewing tobacco or gum should be discouraged.

3.07 The air in rooms where lead is melted or fabricated should be tested frequently. The toxic limit of 1.5 mg. per 10 cu. meters of air should not be exceeded.

3.08 Tetraethyl lead used in motor gasoline is an extremely dangerous poison. It may readily be absorbed by a healthy unbroken skin and has been the source of fatal lead poisoning. It is unlikely that contact will be made with this chemical in concentrated form, but the use of ethyl gasoline as a solvent for cleaning or as a fuel for torches and similar equipment should be prohibited. Single exposure to the dilute solution of tetraethyl lead may cause no ill effects but prolonged contact or repeated exposure should be avoided.

3.09 Workers in lead should have a complete physical examination, including blood counts, every three months. Early detection and treatment

~~SECRET~~

of lead intoxication may permit easy control by the physician. If neglected, it may result in protracted disability or death.

References: National Safety Council Health Practices Pamphlets, No. 3 "Lead," No. 65 "Teaching Safety to New Employees," No. 32 "Exhaust Systems" and No. 37 "Industrial Ventilation."

Prepared by
Safety and Accident Prevention Branch.
Approved by
Medical Division,
Manhattan District,
U. S. Engineer Department.
28 June 1946.

~~SECRET~~

~~SECRET~~

MERCURY

Precautions to be Observed in Handling,
Shipping and Storage.

1. Properties.

1.01 Mercury (Hg) is the only common metal which is liquid at ordinary temperatures. It occurs free in nature and as the sulphide, Cinnabar, (HgS), the latter being the principal source. It is a heavy, silver white liquid extensively used in technical instruments and laboratory apparatus.

1.02 Mercury has a density of 13.55 grams per cubic centimeter, a melting point at -38.9°C (-34.4°F) and a boiling point at 356.9°C (675°F). The following table of vapor pressures is significant when considering the volatility of mercury and the contamination of the atmosphere.

Temperature OF	Vapor Pressure, mg. Hg.	mg. Hg. per Cu. Meter of Air.
0	0.000023	0.3
32	0.000185	2.2
50	0.000490	5.6
60	0.000816	8.7
70	0.00131	14.0
80	0.00212	22.0
90	0.00326	35.0
100	0.00507	53.0

From the above, it is apparent that mercury is readily volatile at ordinary temperatures and that the atmosphere in any confined space may easily become contaminated to a degree greatly in excess of the toxic limit of 0.1 mg. per cubic meter of air if mercury is spilled or exposed in open vessels. It is important to remember that even very small amounts of mercury vapor in a room may result in serious poisoning.

2. Physiological.

2.01 Mercury poisoning may result from contact, inhalation, or ingestion and may be either chronic or acute. Extended exposure to contaminated air containing amounts of mercury in the degree of 0.5 mg., or less, per cubic meter of air, ingestion of relatively small amounts of mercury, or its salts, with food, candies, or tobacco, or frequent skin contact, may result in chronic poisoning. Greater exposure may result in acute poisoning. Industrial mercury poisoning occurs largely from the inhalation of contaminated air. It may occur from contamination of a cigarette carelessly laid on a work bench or from candy or

~~SECRET~~

food eaten in the workroom.

2.02 Symptoms of chronic poisoning include such general disabilities as insomnia, depression, irritability, stomatitis (inflammation of the mouth), gingivitis (inflammation of the gums), which are characteristic of other diseases. Therefore, in each instance of reference to a physician, information regarding possible exposure to mercury should be furnished in detail. Mercury poisoning of the acute type is characterized by abdominal pain and vomiting, a metallic or fetid breath and, in severe cases, tremor of face, hands, and arms, exaggerated knee jerk and salivation. Symptoms may not all be present simultaneously nor to the same degree. While individuals may exhibit a difference in resistance, allergy or exaggerated sensitiveness has no application in mercury poisoning. Treatment of mercury poisoning is difficult, prognosis unfavorable, and the damage liable to be permanent. Complaints of ill feeling on the part of workers exposed to contact with mercury should not be ignored, but should be referred to a physician with complete information regarding possible exposure.

3. Precautions.

3.01 Mercury should be stored in earthenware or iron flasks. With many metals, such as copper, tin, lead and zinc, it forms amalgams and will leak through a soldered joint. If used, or temporarily stored, in open glass or porcelain receptacles, it should be covered with water. Thin-walled beakers or flasks are not safe containers for mercury.

3.02 Laboratory apparatus, in which mercury is used in levelling flasks or similar contrivances, should have the mercury removed and properly stored in suitable flasks whenever such equipment is in stand-by or out-of-service condition.

3.03 Spillage of mercury should be avoided and means should be provided to prevent dispersion over bench tops, tables, and floors wherever spillage may occur. Wherever mercury is used in levelling flasks, diffusion pumps or similar equipment, spillage pans made of rubber, plastic, or other organic material should be provided, and kept clean.

3.04 Work space where mercury is used should be well ventilated. Floors should be smooth and free from cracks.

3.05 In the event of spillage, the floor should be wet down with water and carefully cleaned. Dry sweeping should be prohibited.

3.06 Periodic tests of the atmosphere in any working space where mercury is handled should be made at sufficiently close intervals to

~~SECRET~~

~~SECRET~~

make sure that contamination at no time exceeds 0.1 mg. per cubic meter of air.

3.07 No food should be kept nor eaten in the workroom where mercury is used. Cigarette and cigar smoking should be restricted and should be prohibited while actually handling or transferring mercury.

3.08 Employees working with mercury should be given a complete physical examination every three months. The physician should be informed of exposure to mercury.

Prepared by
Safety and Accident Prevention Branch
Approved by
Medical Division
Manhattan District
U. S. Engineer Dept.
24 June 1946.

~~SECRET~~

~~WAR DEPARTMENT~~
CORPS OF ENGINEERS
Office of the District Engineer
MANHATTAN DISTRICT
Oak Ridge, Tennessee

EIDMN-1

9 September 1946.

DISTRICT CIRCULAR LETTER (Safety 47-2)

SUBJECT: Handling, Storage and Shipping of Chemicals.

TO: All Concerned.

1. Two instances of improper and unsafe shipment of chemicals have recently occurred in the District. In both instances, warehouse and transportation employees were exposed to possible serious injury by contact with hydrofluoric acid. Hazardous storage of acid carboys and other chemicals has been observed in warehouses.

2. Therefore, the following regulations are established for the handling, storage and shipping of chemicals:

a. The minimum requirements for packing, labeling, and shipping of compressed gases, acids, alkalies, solvents and other dangerous chemicals shall be those of the Interstate Commerce Commission, as published in "Regulations for Transportation of Explosives and Other Dangerous Articles." These regulations may be obtained from the Superintendent of Documents, Washington, D. C.

b. The minimum requirements for handling and storage of compressed gases, acids, alkalies, solvents, and other dangerous chemicals shall be those prescribed in the Manual Sheets published by the Manufacturing Chemists' Association. The complete set of Manual Sheets may be obtained from the Manufacturing Chemists' Association, 608 Woodward Building, Washington 5, D. C.

c. Such additional precautions may be prescribed as project management may deem advisable for safety or security.

d. Separate suitable storage space for chemicals shall be provided. Chemicals and medical supplies shall not be stored in warehouses with miscellaneous equipment and supplies.

e. Warehouse employees shall be carefully instructed in the safe handling of gas cylinders, carboys, and other containers of chemicals and shall be provided with all necessary personal protection.

f. Broken packages of chemicals, broken carboys, carboys in defective boxes, or carboys without approved carboy stoppers securely wired,

~~SECRET~~

CS-59
CS-7d

9 September 1946.

SUBJECT: Handling, Storage and Shipping of Chemicals.

compressed gas cylinders without protective caps or with defective or leaking valves must not be shipped to, nor received by, Surplus Property Warehouses.

g. Empty carboys may be shipped to, and received by, the Surplus Property Warehouses only when completely empty, unbroken, securely boxed, and plainly marked to show the chemical for which they had been used and the name of the shipper.

h. Empty compressed gas cylinders may be shipped to, or received by, the Surplus Property Warehouse only when reduced to atmospheric pressure and plainly marked to show the gas for which they had been used and the name of the shipper.

i. Metallic mercury is not classified by the Interstate Commerce Commission as a dangerous material but adequate packing is necessary to prevent spillage. Mercury is volatile at ordinary temperature, the vapor is very poisonous, and leakage must, therefore, be avoided. Mercury should be shipped only in approved steel flasks or stoneware jugs, securely stoppered.

j. Fluorine and uranium fluoride shall not be shipped to, nor received by, Surplus Property warehouses without prior arrangement having been made with the District Surplus Property Office for each specific shipment.

For the District Engineer:

Norman Marsden

NORMAN H. MARSDEN,

Acting District Safety Engineer.

DISTRIBUTION:

AE

H

E

Surplus Property Officer (10)

Safety (25)

The following Safety Circular Letters are still in effect; all others have been rescinded:

43-1 & Suppl. 1	44-5	45-1	47-1
	44-10	45-2	46-1
	44-12 & Suppl. 1	45-3	46-3
		45-4	46-4
			46-5
			46-6
			46-7
			46-8

COPY

COPY

EIDMN-1

18 June 1946.

Subject: Transite Explosion.

To:

1. The following details of a transite explosion were reported by the Madison Square Area Office and are being forwarded for your information:

a. A piece of flat transite wallboard exploded while cooling. Fragments of the board were driven into timbers approximately fifteen feet away and completely through a composition plyboard partition at that distance.

b. Investigation revealed that the board, which had been used as a cover for the door of an electric furnace, overlapped the furnace opening approximately six inches on each side, and had been heated to between 1200° F and 1400° F for about twenty minutes. It had then been placed on its edge on the concrete floor, leaning against a wall to cool. While in this position, it literally exploded into small fragments. This piece had been heated and cooled twice before without any unusual effects.

c. Transite is made of Portland cement and asbestos fibre pressed into one homogeneous sheet under pressure. It contains about 14 % water of crystallization and will absorb up to 20% moisture on exposure to moist air. The asbestos fibre starts to break down as a binder at 700° F and completely loses its strength as a binder at about 900° F.

d. In the case of this accident, it is believed that all outside moisture had been driven off, as well as the water of crystallization, without any noticeable effect. However, the center section exposed to the high heat had lost its structural strength and, due to the uneven heating and the uneven cooling of the piece of transite, strong internal stresses were build up which resulted in the rupturing and disintergration.

~~SECRET~~

COPY
CS-5h
25-18

~~COPY SECRET~~

Subject: Transite Explosion.

2. The manufacturer of the transite in question recommends that it not be exposed to temperatures over 500° F because of its lack of strength after that point, plus a known history of "exploding" at higher temperatures. Caution should be used in selecting materials of this nature for use within temperature ranges recommended by the manufacturers.

3. This office will appreciate receiving information on accidents of an unusual nature for dissemination throughout the District.

For the District Engineer:

NORMAN H. MARSDEN,
Acting District Safety Engineer.

COPY
- 2 -

~~SECRET~~

~~SECRET~~

~~SECRET~~

BERYLLIUM

Precautions to be Observed in Handling,
Shipping, and Storage.

1. Properties.

1.01 Beryllium (Be) is a hard, gray metal used principally with copper as an alloy. Beryllium-copper alloy has good electrical conductivity, and is non-magnetic, non-sparking, and corrosion-resistant. It has extensive application in precision instruments, non-sparking tools, airplane fittings, and telephone equipment. The salts have application in the fluorescent lamp industry.

1.02 Beryllium has a density of 1.85. The melting point is 1350°C (2462°F), and boiling point 1500°C (2732°F). Extraction and reduction of the metal from the ore is not a simple operation. Processing involves high temperatures, treatment with strong acids, and fusion. Fumes and dust containing the beryllium salts are generated at various stages of the process. In the lamp industry, processing creates similar potential hazards.

2. Physiological Effects.

2.01 Beryllium poisoning manifests itself by inflammatory attacks on the skin and mucous membranes: externally, as contact dermatitis and ulcers; internally, as nasopharyngitis, tracheobronchitis (inflammation of the throat, and windpipe and its branches), and pneumonitis (an inflammation of lungs). Contact dermatitis is frequently severe and usually occurs as the result of skin contact with soluble beryllium salts such as fluorides, chlorides, nitrates, and sulphates. Beryllium ulcer usually follows injuries of the skin such as cuts, abrasions, etc. Particles of the beryllium compound enter the wound and develop a site around which the ulcer forms. Internal inflammation results from the inhalation of salts and oxides of beryllium in dust or fumes. There is also recent evidence that the metal itself is toxic, and breathing the metallic dust should be avoided. Pneumonitis, induced by such exposure, is the most severe form of beryllium poisoning and has terminated fatally in a number of cases.

2.02 The incidence of beryllium poisoning in ore-reduction plants and fluorescent lamp factories has been very high. During a four-year period 170 cases occurred in three ore-reduction plants, of which five were fatal. It is reported that the experience of the lamp industry has been similar, with seven or eight fatal cases. Employment in these industries is not high.

~~SECRET~~

CS-51
CS-5

~~SECRET~~

3. Precautions.

3.01 The prime fundamental precaution in processing beryllium is cleanliness. Floors, structural members, and equipment should be kept free from dust. If salts or liquors are spilled, they should be immediately cleaned up.

3.02 Every part of the process in which dust or fumes are created should be equipped with carefully designed mechanical exhaust. Neoprene or rubber gloves should be worn whenever operations may result in skin contact with beryllium compounds. Workers who have abrasions, cuts, etc., on hands or forearms should exercise extreme care in handling beryllium or its compounds even though neoprene or rubber gloves are worn. (Refer to par. 2.01)

3.03 Ample washing facilities should be provided and all workers instructed in the necessity for careful observance of personal hygiene.

3.04 Beryllium compounds should be stored and shipped in tight substantial containers.

3.05 Complaints of sore throat by workers or any indication of skin rashes or sores should be referred to a competent industrial physician with all available information regarding possible exposure to beryllium compounds.

Reference: Beryllium Poisoning by Van Ordstrand, Hughes, De Nardi and Carmody - Journal of the American Medical Association - Dec. 15, 1945.

Prepared by
Safety and Accident Prevention Division.
Approved by
Medical Division,
Manhattan District,
U. S. Engineer Department.
2 October 1946.

~~SECRET~~

~~SECRET~~

MANHATTAN DISTRICT HISTORY

BOOK I - GENERAL

VOLUME 11 - SAFETY PROGRAM

SUPPLEMENT TO APPENDIX "D"

- DS-5 Sample Traffic Accident Report
- DS-6 Sample Fire and Explosion Report Form
- DS-7 Sample First Aid Treatment Report

~~SECRET~~

~~SECRET~~
MONTHLY REPORT OF VEHICULAR ACCIDENTS

CLINTON ENGINEER WORKS

DECEMBER 1946

1. Number of Accidents: The number of accidents reported for December increased approximately 20 percent as compared with November.

Of the one hundred and three accidents that were reported, fifty four percent involved Government owned vehicles. Four of these occurred "Off Area".

The accident experience of Government owned vehicles for December compares very favorably with preceding months of the year. Specifically, the total Government involved accidents for December represents the smallest number of accidents for any of the months of the year with the exception of November and June.

This comparison, together with a comparison with the same months of 1945, is outlined specifically as follows:

<u>MONTH</u>	<u>NUMBER OF ACCIDENTS - 1946</u>			<u>NUMBER OF ACCIDENTS - 1945</u>		
	<u>Gov't. Vohs.</u>	<u>Pvt. Vohs.</u>	<u>Total</u>	<u>Gov't. Vohs.</u>	<u>Pvt. Vohs.</u>	<u>Total</u>
January	110	46	156	226	69	295
February	75	29	104	189	57	246
March	71	31	102	251	92	343
April	88	37	125	259	84	343
May	96	30	126	304	73	377
June	49	37	84	265	74	339
July	84	30	114	246	87	333
August	93	37	130	274	88	362
September	102	37	139	183	90	273
October	76	47	123	154	51	205
November	51	35	86	109	48	157
December	56	47	103	128	54	182
TOTALS	951	443	1392	2588	867	3455

Normally, vehicular accidents increase sharply over Holidays and weekends. That has not been the case in Oak Ridge.

During the past year an average of approximately four accidents were reported per day, while the average for Holidays was less than two. Likewise, there were eleven "No Accident Days" during the year. Six of these were Sundays, two were Saturdays, two were Mondays and one was Friday.

The largest number of accidents reported for any one day during the year was fourteen which was on 24 January and on Thursday.

~~SECRET~~

Severity of Accidents: One hundred and eighty four vehicles were involved in accidents. Seventy six were Government owned and one hundred eight were privately owned.

Forty four of the Government vehicles were damaged at an estimated cost of \$2,297.77.

Ninety three private vehicles were damaged at a total estimated cost of \$3,729.00.

These figures represent an average cost of approximately \$52.00 per Government vehicle and \$40.00 per private vehicle.

2. Personal Injuries: Seventeen persons were injured in vehicular accidents in December. None of this number were classified as severe.

Two of the injured persons were pedestrians and the remainder were drivers or passengers of vehicles.

Government owned vehicles were involved in eight of the injury accidents.

The December injury accident experience is slightly worse than that of November but compares very favorably with other months of the year. This comparison is outlined in detail as follows:

MONTH	NO. INJURED - 1946			NO. INJURED - 1945			PERSONS KILLED	
	Gov't.	Pvt.	Total	Gov't.	Pvt.	Total	1946	1945
January	5	12	17	23	14	37	1	1
February	10	9	19	4	18	22	0	1
March	9	12	21	15	8	23	0	1
April	28	15	43	14	13	27	1	1
May	22	5	27	51	19	70	0	1
June	14	1	15	36	18	54	0	0
July	25	2	27	28	16	44	0	1
August	25	12	37	23	18	41	0	0
September	28	10	38	22	15	37	0	0
October	14	13	27	34	14	48	0	0
November	2	11	13	5	13	18	0	1
December	8	9	17	12	20	32	0	1
TOTALS	*190	111	301	267	186	453	2	8

NOTE: This figure includes 95 persons who sustained minor injuries in getting on or off busses or while riding busses. Incidents of this nature, which are non-collision and involve no property damage, were not reported as vehicular accidents during 1945. This fact accounts to some extent for the comparatively small difference in the number of persons injured from month to month of 1946 as compared with the same months of 1945.

3. Kind of Locality: Thirty percent of the "Government involved accidents" occurred in Manufacturing or Industrial Districts, twenty six percent occurred in Shopping or Business Districts, twenty one percent occurred in Residential Districts and the remainder occurred in School or Playground Districts or Open Country.

The distribution of accidents from the standpoint of reporting agencies and the general location of accidents is outlined below:

a.	Accidents that occurred on the Area (Outside Restricted Areas) that were investigated by the Oak Ridge Police Department	73
b.	Accidents that occurred on the Area (Outside of Restricted Areas) that were reported by Contractor Safety Sections and were not investigated by the Oak Ridge Police Department	12
c.	Accidents that occurred on the Area within Restricted Areas that were reported by Contractor Safety Sections	12
d.	Accidents involving Government owned vehicles that occurred on the Area (Outside Restricted Areas) that were reported to the Accident Investigation Unit by Drivers and that were not investigated by the Oak Ridge Police Department	2
e.	"Off Area" Accidents involving Government owned vehicles that were reported to the Accident Investigation Unit by drivers	4
) TOTAL ACCIDENTS REPORTED		103

4. Type of Accident: Eighty four percent of the Government involved accidents were collisions between two or more vehicles, fifteen percent were collisions with fixed objects and one percent were pedestrian accidents.

Sixty five percent of the "Private Only" accidents were collisions of two or more vehicles.

Seventy percent of the "Government involved" accidents were classified as "Two Motor Vehicle Non-Intersection Accidents". Twenty three percent of these were "Same Direction - rear end collision", twenty percent were "Same Direction - sideswipe collision", twenty percent were "One car backward from parked position", twelve percent were "One car parked - proper location", and the remainder were equally distributed as to type.

5. Approximate Speed (Preceding Accident): Fifty three percent of the Government vehicles were traveling 0 to 10 miles per hour preceding the accident. Only ten percent were reported as traveling more than 20 miles per hour preceding the accident.

6. Driver Violations Indicated: Forty three percent of the Government Drivers were charged with one or more violations.

Sixty four percent of the drivers of private vehicles were in violation.

The most frequently reported violations are listed in order of frequency as follows:

a. Exceeding safe speed - but not stated limit	24
b. Following too closely	17
c. Improper starting from parked position	17
d. On wrong side of road - not in passing	10
e. Did not grant right of way to vehicle	10
f. Under influence of alcohol (all private)	7
g. Other improper backing (turning or backing into platform)	7

7. Vision Obscurments: Vision obscurments were reported in ten instances. Only two of this number were Government owned vehicles.

Two were "Rain, snow, etc. on windshield", six were "Windshield otherwise obscured" and two were "Parked cars".

8. Motor Vehicle Defects: Defective brakes was the most frequently reported motor vehicle defect. It was reported for four Government owned vehicles and thirteen private vehicles.

9. Hour of Day: Fifty five percent of the accidents occurred between 8:00 A. M. and 6:00 P. M.

Twenty five percent occurred between 1:00 P. M. and 4:00 P. M.

The largest number of accidents for a one hour period was nine which occurred within the periods of 2:00 P. M. to 3:00 P. M., 3:00 P. M. to 4:00 P. M. and 4:00 P. M. to 5:00 P. M.

Second largest, eight, occurred between 7:00 A. M. and 8:00 A. M.

During the period there was at least one accident reported for each hour of the day.

The largest number of Government involved accidents occurred between 3:00 P. M. and 4:00 P. M. while Private Only accidents occurred most frequently between 4:00 P. M. and 5:00 P. M.

10. Day of Week: "Government involved" accidents occurred most frequently on Thursday. Wednesday and Monday (an equal number) were second and Tuesday was third. Only one "Government involved" accident occurred on Saturday.

The largest number of "Private Only" accidents (13) occurred on Saturday. An equal number, six, happened on Monday, Tuesday, Thursday and Friday and five occurred on each of the other two days - Wednesday and Sunday.

During the past year there were eleven "No Accident Days". Six were Sundays, two were Saturdays, two were Mondays and one was Friday.

11. Age, Sex and Race of Drivers: The age, sex and race of drivers that were involved in accidents are indicated as follows:

	<u>Gov't.</u>	<u>Pvt.</u>
1. Under 18 years of Age (License Age)	0	4
2. 18 - 19 Years	2	1
3. 20 - 24 Years	10	16
4. 25 - 34 Years	33	36
5. 35 - 44 Years	14	22
6. 45 - 54 Years	5	14
7. 55 - 64 Years	1	2
8. 65 - 74 Years	0	1
9. 75 and Over	0	0
10. Not Stated	8	9
	<hr/>	<hr/>
TOTAL DRIVERS	73	105

Drivers were divided as to sex as follows:

	<u>Gov't.</u>	<u>Pvt.</u>
1. Male	68	89
2. Female	1	13
3. Not Stated	4	3
	<hr/>	<hr/>
TOTAL DRIVERS	73	105

Race of Drivers

	<u>Gov't.</u>	<u>Pvt.</u>
1. White	66	102
2. Negro	1	0
3. Other	0	0
4. Not Stated	6	3
	<hr/>	<hr/>
TOTAL DRIVERS	73	105

12. Residence of Drivers: Sixty three percent of the drivers of Government owned vehicles were residents of Oak Ridge.

Eighty three percent of the drivers of private vehicles were residents.

13. Government Drivers Permits and/or State Drivers License: Only two drivers of Government vehicles did not have valid Government Drivers Permits at the time of accidents.

Eighty three percent of the drivers of private vehicles had valid State Drivers License.

14. Condition of Driver: "Had been drinking" was reported in seven instances all of which involved drivers of private vehicles.

15. Road Conditions and Weather were reported as possible contributory causes of accidents as outlined below:

	<u>Gov't.</u>	<u>Pvt.</u>
1. Foreign material on surface	22	10
2. Road under construction or repair	1	2
3. Road - wet, muddy	8	18
4. Grade or hill	15	35
5. Curve or turn	3	11
6. Weather - cloudy, fog, etc.	4	13
7. Weather - rain, snow or sleet	4	15
TOTAL	57	104

NOTE: A comparison of the tabulations of number of accidents, number of injuries, etc., which appears in the forepart of this report, with tabulations that appeared in the same manner in the November report and in preceding reports will reveal some discrepancies in totals. These differences are due to the fact that a search of the files subsequent to preparation of this report, revealed reports of accidents that had been filed without being tallied and, therefore, had not been accounted for in the monthly reports. The data from these reports has been included in the tabulations and cumulative totals of this report.

Prepared by:

Accident Investigation Unit
Safety Section
Department of Public Safety
24 January 1947

~~SECRET~~

FIRE OR EXPLOSION REPORT		Subject: _____	Date of Report: _____
-9:		Location: _____	Reported by: _____
Type of Incident: <input type="checkbox"/> Fire <input type="checkbox"/> Explosion	Date of Incident: _____	Day of Week: _____	Time of Day: _____ A.M. _____ P.M.
	Government Loss: \$ _____	Private Loss: \$ _____	Interruption to production or Research: <input type="checkbox"/> Yes <input type="checkbox"/> No

A. Story of Incident:

B. Extinguishment of Fire:

C. Comments and Recommendations:

Instructions:

- A. Describe building or equipment involved, cause of fire, extent and damage.
- B. Who responded to the alarm and what method was used to extinguish fire.
- C. Indicate any pertinent facts not covered in A. and B. or which may clarify report, and list recommendations.

~~SECRET~~

ADDRESS REPLY TO:
 DISTRICT ENGINEER
 MANHATTAN DISTRICT
 CORPS OF ENGINEERS
 P. O. BOX 1548
 OAK RIDGE, TENNESSEE
 REFER TO FILE NO. EIDMQ-64

WAR DEPARTMENT
 CORPS OF ENGINEERS
 OFFICE OF THE DISTRICT ENGINEER
 MANHATTAN DISTRICT
 OAK RIDGE, TENNESSEE

14 October 1946.

Subject: First Aid Stations, 3 September through 27 September 1946.

MEMORANDUM to Mr. J. R. Maddy, Safety Division.

The following report covering the operation of the First Aid Stations is submitted for your information:

Sta. No.	Location	Period Covered	Treatments		Totals	
			Occupational	Non-Occupational	Occupational	Non-Occupational
1	U.S.E.D. Adm. Bldg.	9/3-9/6	10	74	52	332
		9/9-9/13	10	88		
		9/16-9/20	21	73		
		9/23-9/27	11	97		
2	C-2 Warehouse	9/3-9/6	6	3	79	69
		9/9-9/13	22	31		
		9/16-9/20	37	19		
		9/23-9/27	14	16		
3	Gamble Valley	9/3-9/6	20	22	124	76
		9/9-9/13	38	14		
		9/16-9/20	42	25		
		9/23-9/27	24	15		
4	Roane- Anderson Main Bldg.	9/3-9/6	6	95	37	386
		9/9-9/13	6	103		
		9/16-9/20	9	81		
		9/23-9/27	16	107		
5	4th Echelon Repair Shops	9/3-9/6	29	35	194	203
		9/9-9/13	51	58		
		9/16-9/20	48	55		
		9/23-9/27	66	55		
Totals, All Stations					486	1066

7

D. G. Williams
 D. G. WILLIAMS,
 Lt. Col., Corps of Engineers,
 Chief, Dept. of Public Safety.

DS-7
 10-17-46

~~SECRET~~

MANHATTAN DISTRICT HISTORY

BOOK I - GENERAL

VOLUME 11 - SAFETY PROGRAM

SUPPLEMENT TO APPENDIX "E"

PHOTOGRAPHS OR PHOTOSTATS OF:

- ES-10 Award of Honor Presentation for Schools
- ES-11 Awards of Distinguished Service to Safety (2)
- ES-12 National Traffic Safety Contest Award
- ES-13 National Award of Merit, Record of Merit, Fire Prevention Week October 1945.
- ES-14 Fire Prevention Training and Inspection
(1 composite and 2 regular)
 - a. Fire Prevention in Oak Ridge
 - b. Fire Prevention at Gas Stations
 - c. Fire Prevention at Schools

SECRET



Presentation
of National
Safety Council
"Honor Roll"
for Exceptional
Effort
in Safety to
Oak Ridge
Schools on
27 August 1946
Presentation
made by Lt.
Col. C.C. Noble
Exec. Officer,
Manhattan Dist.



The National Safety Council

Hereby presents to

The Manhattan District

this

Award of Honor

for

Distinguished Service to Safety

For outstanding success in controlling accidents at plants and laboratories concerned with the production of atom bombs from June 30, 1945 to June 30, 1946.



Ned H. Dearborn
President



The National Safety Council

Hereby presents to

Manhattan **D**istrict
Corps of Engineers

this

Award of Honor

for

Distinguished Service to Safety

In achieving and maintaining outstandingly low accident rates at the Manhattan District facilities throughout the country under the urgent demands for speed in the unique processes attending the development of the Atomic Bomb, and thus making a signal contribution to early Victory.

Presented at Washington, D.C.
December 9th, 1945



Ned H. Dearborn
President

**NATIONAL TRAFFIC
SAFETY CONTEST**



OAK RIDGE, TENNESSEE

1945

AWARD OF MERIT

PRESENTED BY

NATIONAL SAFETY COUNCIL

NATIONAL FIRE PROTECTION ASSOCIATION

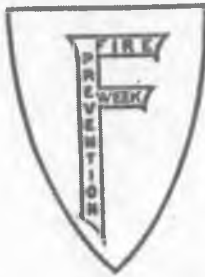

Committee on Fire Prevention and Clean Up Campaign

Hereby Certifies that OAK RIDGE
has been awarded HONORABLE MENTION, TENNESSEE in the

Record of Merit

For Educational Activities Promoted During

FIRE PREVENTION WEEK

October 7 - 13, 1945

In Witness Whereof the undersigned have affixed their signatures
this eighteenth day of February, 1946



J. Christensen
Frank [unclear]

Clarence C. Johnson
[unclear]
Committee of Judges

[Signature]
General Manager

[Signature]
Chairman of Fire Prevention
and Clean Up Committee



Please
**DRIVE
TO
RIGHT**

ESSEX EXTRA
789
580
CONTAINS LEAD
ETHYL

Esso
289
280
280
280
280
CONTAINS LEAD

SPORTING

Esso
WATER BY

Esso
WATER BY

ESSEX

ESSEX





F 3-14 c

~~SECRET~~

MANHATTAN DISTRICT HISTORY

BOOK I - GENERAL

VOLUME 11 - SAFETY PROGRAM

SUPPLEMENT TO APPENDIX "F"

SE-6

List of Films Available for Use.

~~SECRET~~

[REDACTED]
WAR DEPARTMENT
CORPS OF ENGINEERS
Office of the District Engineer
MANHATTAN DISTRICT
Oak Ridge, Tennessee

EIDMJ-4

20 November 1946.

DISTRICT CIRCULAR LETTER (Safety 47-3)

SUBJECT: Revised List of Motion Picture and Slide Films Available for Loan.

TO: All Concerned.

1. Attached is a list of films available for loan by this office. The list is revised and supersedes list inclosed with District Bulletin dated 20 February 1946, subject as above.

2. Requests for films should be forwarded to the attention of the District Safety Division at least two weeks in advance of the date required and should indicate an alternate choice in the event the first selection is not immediately available.

3. Films will be loaned for a period of two weeks unless the request is for a longer period, which will be arranged if compatible with any other loans scheduled.

For the District Engineer:

James R. Maddy
JAMES R. MADDY,
District Safety Engineer.

1 Incl. ;
List of Films

DISTRIBUTION:

AE
H
Safety Division (100)

The following Safety Circular Letters are still in effect; all others have been rescinded:

43-1 & Suppl. 1	45-1	46-1	47-1
	45-2	46-3	47-2
44-5	45-3	46-4	
44-10	45-4	46-5	
44-12 & Suppl. 1		46-6	
		46-7	
		46-8	

~~SECRET~~
MOTION PICTURE FILMS AND SLIDE FILMS
AVAILABLE ON LOAN FROM SAFETY DIVISION
MANHATTAN DISTRICT
OAK RIDGE, TENNESSEE

I. 16 mm MOTION PICTURE FILMS. (Sound, except as noted)

A. MOTOR VEHICLE OPERATOR TRAINING.

1. Guilty. A dramatic of a young man who refuses to take safety seriously. Considerable specific traffic information included. 30 minutes.
2. Hell Wouldn't Have Him. Adult truck drivers are shown the results of carelessness on the highways. 30 minutes.
3. It's Wanton Murder. How reckless driving affects an American family. Narrated by Lowell Thomas. 15 minutes.
4. School Bus Operation. Shows the importance of maintenance and emphasizes safe driving habits. 13 minutes.
5. Singing Wheels. This film shows importance of truck drivers in our transportation system. 23 minutes.
6. The Operator and His Passengers. Points out ways of handling problems that may arise such as expired transfers, people who miss their stops, the talkative person, and getting passengers to move to the rear. 18 minutes.
7. Uncle Jim Tells 'Em. This film is a dramatization of safety rules for driving. 15 minutes.
8. When You Know. Shows that if training is necessary for an airplane pilot, then it is also essential for the automobile driver. 12 minutes.
9. With Care. Points out what the truck driver does to make him the safest driver on the road. 12 minutes.
10. Youth Takes to the Highway. Training high school pupils how to drive. 12 minutes.

B. FIRE PREVENTION, PROTECTION, AND EXTINGUISHMENT.

1. A Word to the Wise. Shows causes of fires, cost of fires, and measures to be used in fire prevention in the home. 12 minutes.
2. Before the Alarm. Depicts fundamental fire protection needs of an average community. 10 minutes.

Inclosure to D/C/L (Safety 47-3) dated 20 November 1946, subject, "Revised List of Motion Picture and Slide Films Available for Loan."

~~SECRET~~

3. Control of Flammable Liquids. Methods of handling volatile and flammable liquids are portrayed. 25 minutes. (silent)
4. How Fires Start in Industry. A close-up of actual fire causes in industrial plants. 30 minutes. (technicolor)
5. Fire Safety. Shows how to avoid fires, particularly around the home. 18 minutes. (silent)
6. Fire Prevention. The first half of this film deals with fire prevention in building construction and the second half is an appeal for fire prevention in the home. 16 minutes. (silent)
7. Flame Facts. This film in technicolor classifies various types of fires and demonstrates use of all types of fire extinguishers. 11 minutes.
8. More Dangerous Than Dynamite. Covers accident and fire prevention in the home. Safe handling of flammable liquids. 9 minutes.
9. Preventing Fires Through Electrical Safety. Home and public fire prevention. Deals with proper handling and maintenance of electrical equipment. 30 minutes. (silent)
10. Sixty Seconds to Safety. Demonstrates some of the common causes of fires in the school. Shows unsafe practices such as waste paper carelessly left on stairs, furniture blocking exit doors, etc. 12 minutes.

C. INDUSTRIAL SAFETY.

1. A Safe Day. In this film we see Bill Jones, worker, applying his knowledge of good safety practices all through the day, at home, in traffic, and in the factory. 15 minutes.
2. Danger - Women at Work. A safety-health film designed especially for women workers in industry. 12 minutes.
3. Factory Safety. Depicts safety work in the average industrial plant and the ideal methods of conducting a safety program. (supervisory) 15 minutes.
4. Fork Truck. (T.F. 104-1080) Shows safe use of equipment in handling materials. 20 minutes.
5. For Safety's Sake. Shows the danger of using defective power tools, and give several rules for the safe use of hand power saws, power drills, etc. (worker) 15 minutes.

~~SECRET~~

6. Four Thousand Years of Experience. Starts with the building by hand of the B-29 airbase in China and brings safety through to its present status in the modern industrial plant. 18 minutes.
7. Kitchen and Dining Room Safety. This film covers common hazards in the kitchen and dining room and demonstrates safe practices. For hotels, cafeterias, lunch rooms, etc. 15 minutes.
8. No Short Cut. Shows safe practices in the public utility industry. Covers handling of materials, hand tools, signs, rules, eye hazards, etc. 33 minutes.
9. Safety in the Shop. Dramatizes typical shop accidents. Emphasizes the supervisor's responsibility in teaching and maintaining safe practices in the shop. 12 minutes.
10. Shop Safety. This film shows precautions to be observed in the automotive machine shop. 28 minutes.
11. Three Dimensional Seeing. Color film demonstrates the new methods of improving industrial seeing conditions through the correct application of color and light to machinery operation. 20 minutes.

D. FIRST AID AND HEALTH.

1. Before the Doctor Comes. For First Aid students. Reel No. 1 - Controlling bleeding and care of shock. Reel No. 2 - Artificial respiration and care of burns. Reel No. 3 - Leg Fractures and application of splints. Reel No. 4 - Arm fractures and transporting victims. 37 minutes.

E. PUBLIC SAFETY.

1. Home Safe Home. This film describes typical home hazards and practical ways of correcting them. 20 minutes.
2. Street Safety. (Primary Grades) Shows correct pedestrian habits for children. 20 minutes.
3. Street Safety. (Advanced Grades) For adults, the film shows right way to cross a street, alight from street cars, how to walk along roads where there are no sidewalks. 20 minutes.

II. 35 mm SLIDE FILMS. (Sound, except as noted)

A. MOTOR VEHICLE OPERATOR TRAINING.

1. Defensive Driving. Features interviews with drivers of various types of trucks, and demonstrates defensive driving

~~SECRET~~

tactics which also are applicable to private motorists.
20 minutes.

2. If It Happens. Primarily for commercial vehicle drivers. Explains and demonstrates what to do in case of an accident. 20 minutes.
3. Learning to Drive. For high school students in driver training courses. Part 1 deals with discussion of parts of the car, etc. Part 2 shows the beginner behind the wheel learning about the controls and gauges, making proper turnings, etc. 30 minutes.
4. Night Driving. This picture shows the difficulty of seeing at night, the effect of glare on the eyes, effect of fog and rain on headlights, stopping distances at night and suggestions for safe night driving. 15 minutes.
5. No Use Skidding. A fast-moving film explaining the major causes of winter traffic casualties. Can be shown to all types of drivers. 15 minutes.
6. Pilots of the Highway. A dramatization of Interstate Commerce Commission Safety Regulations for cross-country truck drivers. 20 minutes.
7. Safety for Sale. Shows an educational highway program. Suitable for guards, police and safety organizations. 15 minutes.
8. Testing the Drinking Driver. A dramatic story of how new scientific tests are being used in drunken driving cases. 20 minutes.
9. Traffic Jam Ahead. Shows new hazards caused by worn out equipment which confront the present day motorist. 20 minutes.
10. Victory Highway. Shows proper maintenance of equipment and the prevention of highway accidents. 20 minutes.

B. FIRE PREVENTION, PROTECTION AND EXTINGUISHMENT.

1. Fire. Shows correct methods of preventing and fighting fires. 20 minutes.
2. Fire is Your Responsibility. How store employees can help prevent fires. Rules covering common situations such as smoking, wiring, store housekeeping and trash disposal. The film closes with a "Photo Quiz," a series of pictures in which the audience is asked to point out typical store fire hazards. 20 minutes.

3. In Case of Fire. This film shows the industrial worker what should be done in case of fire and what should be done to guard against it. 20 minutes (silent)
4. Safe From Fire. (F.S. 20-10) Methods of preventing and controlling fire. 15 minutes (silent)
5. The Fire Thief. Industry's great enemy, what employees can do to prevent it, sources of industrial fires. Good housekeeping is emphasized throughout. 20 minutes.
6. Training for Emergencies. Describes emergency services - clothing on fire - fire in school shop - reporting a fire - using fire extinguisher. (Schools) 15 minutes (silent)

C. INDUSTRIAL SAFETY (EMPLOYEE TRAINING)

1. Care and Use of Chain Falls. Reviews the importance of giving chain falls good care, together with detailed information on selection, operating techniques, and loading factors involved in their use. 5 minutes (silent)
2. Construction Equipment Safety. Covers causes of accident in use of heavy equipment. Stresses importance of following rules and use of good common sense. 20 minutes.
3. Dry Cleaning Installations (F.S. 20-15) Safety pointers for operation. 15 minutes. (silent)
4. Eye Protection. Shows selection, adjustment, and care of chipper goggles, welding goggles, helmets, and hand shields, 18 minutes.
5. Eyes on the Job. A film featuring "Sammy Squint," who advocates the need for better vision in industry in the prevention of accidents. 20 minutes.
6. Fork Lift. (F.S. 20-14) Safe use of equipment in handling materials. 15 minutes. (silent)
7. Giant Hands of Industry. Shows how to operate shop cranes safely. Illustrates the hooker's many responsibilities, approved hand signals, and care in use of various types of hoisting gear. 15 minutes.
8. Good Housekeeping. (F.S. 20-8) Hidden hazards in industrial plants. 15 minutes. (silent)
9. Grime Doesn't Pay. Shows how important good plant house-keeping is in relation to preventing accidents. 20 minutes.

10. Handle with Care. The character in a safety poster comes to life and explains the importance of lifting and handling materials safely. 20 minutes.
11. Handling Pressure Cylinders. Gives detailed information on proper storage, rigging, hoisting, and use of oxygen, acetylene, and other pressure cylinders. 15 minutes.
12. Keep It Clean. Summarizes practical suggestions in individual sanitation. 15 minutes.
13. Laboratory Glassware. Shows safe practices in handling various types of glass apparatus, avoid hazards likely to cause accidents. 10 minutes.
14. Maintaining a Safe Shop. Stresses importance of keeping aisles, floor and stairways safe, disposal of wiping cloths; caution about nails, disposal of scrap materials, handling and storing materials, moving heavy objects. 15 minutes (silent).
15. Men of Maintenance. Railroad maintenance and safe performance of duties. Covers inspections, loading, handling, operation of motor track cars, trailers, and push cars, and emphasizes the importance of being alert at all times. 15 minutes.
16. Minute Men. An action-packed story of safety in the public utility industry. Illustrates safe practices in line work, power stations, meter inspections, etc. 20 minutes.
17. No Laughing Matter. Folks causing biggest share of accidental deaths and serious injuries, and how they can be prevented. 15 minutes.
18. Nothing Upstairs. A cartoon film in technicolor, featuring comic characters "Lulu Drip" and "Hank Fizzle," who are forever getting injured in the plant as a result of most common unsafe acts. 10 minutes.
19. Office Hazards. (F.S. 20-7) Shows common office hazards. 12 minutes. (silent)
20. Play Safe and Work Safely. The safety program in industry - safe dress, shop hygiene, etc. (Workers) 20 minutes.
21. Pole Top Pals. Shows precautions necessary in execution of work on poles. Describes emergency resuscitations from electric shock while still on pole. 20 minutes (silent)
22. Power Supply. Shows best methods of starting and stopping various types of electric power machines. 22 minutes.

~~SECRET~~

- 23. Rules for Tools. Shows safe use of small hand-tools, built around the four rules; "Select the right tool," "Be sure it is in good condition," "Use it properly," and "Put it away safely." 20 minutes.
- 24. Safe Handling of Materials. Covers handling, accident causes such as - snagging hands, rough boards, wire, catching fingers, lifting, dropping objects, carrying, jerking, struggling, etc. 10 minutes.
- 25. Safe Use of Hand Tools. (F.S. 20-13) Shows workers how they can avoid injury to themselves and others. 15 minutes. (silent)
- 26. Safely We Work. Shows railroad yardmen and crewmen how they can avoid accidents on the job. 15 minutes.
- 27. Safely Yours. Helps teach women employees the value of safety in industry. 20 minutes.
- 28. Safety for Defense. Outlines six common causes of industrial accidents and how workers can avoid accidents from these causes, stresses the employee's responsibility to work safely for himself and our nation. 20 minutes.
- 29. The Fall Guy. A story of falls in industry, interspersed with humorous dialogue and demonstrations of falling hazards and methods for eliminating them. 20 minutes.
- 30. Warehousing. (F.S. 10-112) Safe practices in warehouses. 15 minutes. (silent)
- 31. Women and Machines. Stresses huge industrial accidents costs and shows the important part played by women in reducing them. 20 minutes.

D. INDUSTRIAL SAFETY (FOREMANSHIP TRAINING)

- 1. Brains Beats Brawn. Depicts the correct methods in handling materials. 20 minutes.
- 2. Cause and Cure. Shows methods of industrial accident investigation and the correction of accident causes by supervision. 20 minutes.
- 3. Do the Job Right. Depicts problems the foreman is up against in trying to do the job right. Shows how he can find time to plan his program, delegate duties, etc. 20 minutes.

~~SECRET~~

4. Follow the Leader. Shows management and supervisors' joint responsibility, and outlines ten necessary steps in the organization of a safety program. 20 minutes.
5. Guard Duty. Depicts procedures of safe guarding against mechanical hazards. 20 minutes.
6. How to Get Ready to Instruct. Intended for supervisory personnel for better management. 15 minutes.
7. How to Instruct. Presents methods of instructing new employees in the job they are to perform. (Supervisors) 20 minutes.
8. Invisible Red Ink. An appeal to management to recognize the importance of a planned safety program, not only from the humanitarian standpoint, but from the dollars and cents standpoint. 20 minutes.
9. Lets Face the Facts. Shows what to look for in safety and dramatizes the fact that an interruption in production is a clue, pointing to the fact that something has gone wrong. 20 minutes.
10. Principles and Interest. Shows the methods of maintaining employee interest in the safety program. 20 minutes.
11. Production with Safety. Depicts the foreman's responsibilities in controlling workers' acts through training and proper supervision. 20 minutes.
12. Right Dress. Depicts the need for proper selection of protective equipment in industry and emphasizes the need for its use. 20 minutes.
13. Safety is in Order. Shows importance of providing safe working conditions for employees. 20 minutes.
14. Safety Inspection. For the safety engineer. The film suggests duties of the safety engineer, selling safety, getting cooperation from others, making daily safety inspection. 12 minutes.
15. Stop, Look and Listen. A plant safety committee is pictured at work. 20 minutes.

E. FIRST AID AND HEALTH

1. Aids for injuries. Describes first aid for cuts, slivers, punctures, wounds and bruises, particles in eyes, etc. 15 minutes.
2. Artificial Respiration. Demonstrates prone method. 20 minutes (silent)

~~SECRET~~

3. Doctors Orders. Shows treatment of industrial injuries through first aid. 20 minutes.
4. First Aid for Non-Combat Injuries. Stresses the employment of improvised means to provide the necessary first aid. 10 minutes. (silent)
5. Food Keeps You Fit. Depicts proper food for workers. 15 minutes.
6. Open For Infection. Story features worker who has finger injured and then receives some instructions from doctor on consequences of neglect. 20 minutes.
7. Poisonous Snakes of the U. S. Shows types of snakes and first aid for bites. 10 minutes. (silent)
8. Stay on the Beam. A mental hygiene expert discusses a few hints for good morale good mental health. 14 minutes.
9. Take Care of Yourself. Industrial physician and nurse explain how to keep health by observing a few simple rules. 16 minutes.
10. The Cold Bug. Instructs industrial employees on treatment for the common cold. 14 minutes.
11. To the Women. Describes illnesses common to women which cause majority of absenteeism among women workers. 15 minutes.
12. Treatment for Bleeding. Shows what to do when injured: Infection, severe bleeding, fractures, etc. 15 minutes. (silent)

F. PUBLIC SAFETY

1. Are Your Feet Killing You? Shows case history of pedestrian hazards and emphasizes correction. 20 minutes.
2. Child Accidents in the Home. Presents suggestions to parents on prevention of all kinds of home accidents to children. 20 minutes.
3. Double Trouble. Technicolor film showing Lulu Drip and Hank Fizzle who get married and then have accidents in home, on highway and in the plant. 15 minutes.
4. Home Safety. Shows common hazards in every room and how to correct them. 20 minutes.

- 9 -
~~SECRET~~

5. No Time for Goofers. Illustrates hazards encountered on way to and from work. Covering all methods of transportation. 20 minutes.
6. Play Safe. Depicts safety on school playground. 15 minutes. (silent)
7. Safe All Around. A story of off-the-job safety dealing with hazards around the home and their elimination. 18 minutes. (silent)
8. Safe Electrical Equipment for the Home. Shows safe electrical equipment used in the home. 15 minutes. (silent)
9. Safety First. Deals with traffic situations, particularly accidents caused by careless pedestrians. 10 minutes. (silent)
10. Safety on Two Wheels. Shows bicycle safe practices in traffic. 15 minutes. (silent)
11. Tom Joins the Safety Patrol. Describes safety patrol in operation. 10 minutes. (silent)

RESTRICTED DATA

Atomic Energy Act 1946
Specific Restricted Data
Clearance Required